

Advances in Fuzzy Mathematics and Engineering

Fuzzy Sets and  
Fuzzy Information =  
Granulation Theory

Key Selected Papers by Lotfi A. Zadeh

Beijing Normal University Press

463818

# Fuzzy Sets and Fuzzy Information- Granulation Theory

**Key selected papers by Lotfi A. Zadeh**

Edited by Da Ruan  
Chongfu Huang



00463818

Beijing Normal University Press  
Beijing

# CRACKED TRADING SOFTWARE

***70+ DVD's FOR SALE & EXCHANGE***

***[www.traders-software.com](http://www.traders-software.com)***

***[www.forex-warez.com](http://www.forex-warez.com)***

***[www.trading-software-collection.com](http://www.trading-software-collection.com)***

***[www.tradestation-download-free.com](http://www.tradestation-download-free.com)***

## ***Contacts***

***[andreybbrv@gmail.com](mailto:andreybbrv@gmail.com)***

***[andreybbrv@yandex.ru](mailto:andreybbrv@yandex.ru)***

***Skype: andreybbrv***

### 图书在版编目(CIP)数据

模糊集与模糊信息粒理论:英文版/(美)扎德(Zadeh, L. A.)著. —北京:北京师范大学出版社, 2000. 5  
(模糊教学与工程新进展国际系列丛书)  
ISBN 7-303-05324-7

I. 模… II. 扎… III. 模糊集-文集-英文 IV. 0159-53

中国版本图书馆 CIP 数据核字(2000)第 02100 号  
北京市版权局著作权合同登记图字 01-2000-0187 号

北京师范大学出版社出版发行

(北京新街口外大街 19 号 邮政编码:100875)

出版人:常汝吉

北京师范大学印刷厂印刷 全国新华书店经销

开本:890mm×1 240mm 1/32 印张:16.375 字数:472 千字

2000 年 5 月第 1 版 2000 年 5 月第 1 次印刷

定价:20.00 元

## **The International Committee of the Series**

Etienne E. Kerre (Belgium)

Da Ruan (Belgium)

Madan M. Gupta (Canada)

Liu Yingming (China)

Wang Peizhuang (China)

Huang Chongfu (China)

Didier Dubois (France)

Hans J. Zimmermann (Germany)

Yee Leung (HK, China)

Hiroshi Inoue (Japan)

Masahara Mizumoto (Japan)

Zeungnam Bien (Korea)

A. J. van der Wal (Netherlands)

Janusz Kacprzyk (Poland)

Bart Kosko (USA)

George Klir (USA)

Paul P. Wang (USA)

(Note: the order is according to the countries' names)

## Preface

**Advances in Fuzzy Mathematics and Engineering** is a new international series dedicated to the support and development of the theory of fuzzy mathematics and related areas and their industrial applications in general and in engineering in particular. The series is supported and published by Beijing Normal University Press, Beijing, China.

This book, *Fuzzy Sets and Fuzzy Information-Granulation Theory*, is the third volume of Collected Papers by Lotfi A. Zadeh. The first volume, entitled *Fuzzy Sets and Applications*, was published in 1987 by **John Wiley**. Its editors, Ronald R. Yager, Sergei Ovchinnikov, Richard M. Tong, and Hung T. Ngugen undertook the project on the occasion of the 20th anniversary of the publication of the first paper on fuzzy set by Lotfi A. Zadeh. The second volume, entitled *Fuzzy Sets, Fuzzy Logic, and Fuzzy Systems*, was published in 1996 by **World Scientific**. Its editors, George J. Klir and Bo Yuan selected, from among all papers by Lotfi Zadeh not included in the first volume, those papers on fuzzy sets, fuzzy logic, and fuzzy systems whose easy accessibility would likely be of benefit to those working in these areas. The previous two volumes in English have proved to be great utility to anyone interested in fuzzy set theory and its applications.

Considering the largest number of the readers related to Fuzzy Mathematics and Engineering in China, we felt that a Chinese version of the key selected papers by Lotfi Zadeh *Fuzzy Sets and Fuzzy Information-Granulation Theory* would fit well into the book series on **Advances in Fuzzy Mathematics and Engineering** by Beijing Normal University Press. The book collects Zadeh's original perception which may be viewed as an evolution of ideas rooted in his 1965 paper on *fuzzy sets*; 1971 paper on *fuzzy systems*; 1973 – 1976 papers on *linguistic variables, fuzzy if-then rules and fuzzy graphs*; 1979 paper on *fuzzy sets and information granularity*; 1986 paper on *generalized constraints*; 1996 paper on *computing with words and* 1997 papers on *theory of fuzzy information granulation*.

The purpose of this book is twofold. Firstly, it is intended as a quick reference for those working in *Fuzzy Mathematics and Engineering* in China as well as in the world. Secondly, it is expected to play a major role in Research and Development of *Fuzzy Mathematics and Engineering*, as a useful source of supplementary readings in this new book series. We hope this volume will benefit many readers around the world.

Da Ruan, Chongfu Huang

Editors

## **Note to the Reader**

This book is the third volume of collected papers by Lotfi A. Zadeh. The first volume, entitled *Fuzzy Sets and Applications*, was published in 1987 by **John Wiley** (Editors: Ronald R. Yager, Sergei Ovchinnikov, Richard M. Tong, and Hung T. Ngugen). The second volume, entitled *Fuzzy Sets, Fuzzy Logic, and Fuzzy Systems*, was published in 1996 by **World Scientific** (Editors: George J. Klir and Bo Yuan).

The current edited-book is a set of key selected papers by Lotfi Zadeh. Both English and Chinese versions of these papers are available.





## Acknowledgements

This book consists of the following reprinted (both retyped and translated) papers. The relevant copyright owners whose permissions to reproduce the papers in this book are gratefully acknowledged.

### **Academic Press :**

L. A. Zadeh, "Fuzzy sets." *Information and Control*, 8(3), pp. 338–353, 1965.

L. A. Zadeh, "A fuzzy-algorithmic approach to the definition of complex or imprecise concepts," *Internat. J. Man-Machine Stud.* 8, pp. 249 ~ 291, 1976.

### **Elsevier Science :**

L. A. Zadeh, "The concept of a linguistic variable and its application to approximate reasoning, I, II, III." *Information Sciences*, 8(3), pp. 199 ~ 251, (4)301 ~ 357; 9, pp. 43 ~ 80, 1975.

L. A. Zadeh, "Fuzzy sets and information granularity." In: Gupta, M. M., R. K. Ragade, and R. R. Yager, eds., *Advances in Fuzzy Set Theory and Applications*. North-Holland, New York, pp. 3 ~ 18, 1979.

L. A. Zadeh, "Toward a theory of fuzzy information granulation and its centrality in human reasoning and fuzzy logic." *Fuzzy Sets and Systems* 90 (2), pp. 111 ~ 127, 1997.

### **Institute of Electrical and Electronics Engineers :**

L. A. Zadeh, "Outline of a new approach to the analysis of complex

system and decision processes." *IEEE Trans. On Systems, Man, and Cybernetics*, 1(1), pp. 28~44, 1973.

L. A. Zadeh, "Fuzzy logic = computing with words." *IEEE Trans. On Fuzzy Systems* 4, pp. 103~111, 1996.

**Oxford University Press Inc. :**

L. A. Zadeh, "Towards a theory of fuzzy systems." In: Kalman, R. E. and N. Declaris, eds. , *Aspects of Networks and Systems Theory*. Holt, Rinehart & Winston, New pp. 469~490, 1971.

**Springer Verlag :**

L. A. Zadeh, "Outline of a computational approach to meaning and knowledge representation based on the concept of a generalized assignment statement." In: Thoma, M. And W. Wyner, eds. , *Proc. Of the International Seminar on AI and Man-Machine Systems*. Springer-Verlag, Heidelberg, pp. 198~211, 1986.

## **Lotfi A. Zadeh's biography**

Lotfi A. Zadeh joined the Department of Electrical Engineering at the University of California, Berkeley, in 1959, and served as its chairman from 1963 to 1968. Earlier, he was a member of the electrical engineering faculty at Columbia University. In 1956, he was a visiting member of the Institute for Advanced Study in Princeton, New Jersey. In addition, he held a number of other visiting appointments, among them a visiting professorship in Electrical Engineering at MIT in 1962 and 1968; a visiting scientist appointment at IBM Research Laboratory, San Jose, CA, in 1968, 1973, and 1977; and visiting scholar appointments at the AI Center, SRI International, in 1981, and at the Center for the Study of Language and Information, Stanford University, in 1987 --1988. Currently he is a Professor in the Graduate School, and is serving as the Director of BISC (Berkeley Initiative in Soft Computing).

Until 1965, Dr. Zadeh's work had been centered on system theory and decision analysis. Since then, his research interests have shifted to the theory of fuzzy sets and its applications to artificial intelligence, linguistics, logic, decision analysis, control theory, expert systems and neural networks. Currently, his research is focused on fuzzy logic, soft computing and computing with words.

An alumnus of the University of Teheran, MIT, and Columbia

University, Dr. Zadeh is a fellow of the IEEE, AAAS, ACM and AAI, and a member of the National Academy of Engineering. He was the recipient of the IEEE Education Medal in 1973 and a recipient of the IEEE Centennial Medal in 1984. In 1989, Dr. Zadeh was awarded the Honda Prize by the Honda Foundation, and in 1991 received the Berkeley Citation, University of California.

In 1992, Dr. Zadeh was awarded the IEEE Richard W. Hamming Medal "For seminal contributions to information science and systems, including the conceptualization of fuzzy sets." He became a Foreign Member of the Russian Academy of Natural Sciences (Computer Sciences and Cybernetics Section) in 1992 and received the Certificate of Commendation for AI Special Contributions Award from the International Foundation for Artificial Intelligence. Also in 1992, he was awarded the Kampe de Fariet Medal and became an Honorary Member of the Austrian Society of Cybernetic Studies.

In 1993, Dr. Zadeh received the Rufus Oldenburger Medal from the American Society of Mechanical Engineers "For seminal contributions in system theory, decision analysis, and theory of fuzzy sets and its applications to AI, linguistics, logic, expert systems and neural networks." He was also awarded the Grigore Moisil Prize for Fundamental Researches, and the Premier Best Paper Award by the Second International Conference on Fuzzy Theory and Technology. In 1995, Dr. Zadeh was awarded the IEEE Medal of Honor "For pioneering development of fuzzy logic and its many diverse applications." In 1996, Dr. Zadeh was awarded the Okawa Prize "For Outstanding contribution to information science through the development of fuzzy logic and its applications."

In 1997, Dr. Zadeh was awarded the B. Bolzano Medal by the Academy of Sciences of the Czech Republic "For outstanding achievements in fuzzy mathematics." He also received the J. P. Wohl Outstanding Career

Achievement Award of the IEEE Systems, Man and Cybernetics Society. He served as a Lee Kuan Yew Distinguished Visitor, lecturing at the National University of Singapore and the Nanyang Technological University in Singapore, and as the Gulbenkian Foundation Visiting Professor at the New University of Lisbon in Portugal.

Dr. Zadeh holds honorary doctorates from Paul-Sabatier University, Toulouse, France; State University of New York, Binghamton, NY; University of Dortmund, Dortmund, Germany; University of Oviedo, Oviedo, Spain; University of Granada, Granada, Spain; Lakehead University, Canada; University of Louisville, KY; Baku State University, Azerbaijan; and the Silesian Technical University, Gliwice, Poland.

Dr. Zadeh has authored close to two hundred papers and serves on the editorial boards of over fifty journals. He is a member of the Technology Advisory Board, U. S. Postal Service; Advisory Committee, Department of Electrical and Computer Engineering, UC Santa Barbara; Advisory Board, Fuzzy Initiative, North Rhine-Westfalia, Germany; Fuzzy Logic Research Center, Texas A & M University, College Station, Texas; Advisory Committee, Center for Education and Research in Fuzzy Systems and Artificial Intelligence, Iasi, Romania; Senior Advisory Board, International Institute for General Systems Studies; the Board of Governors, International Neural Networks Society.

## **Contents**

### **Part 1: Fuzzy Sets**

Fuzzy sets 3

### **Part 2: Fuzzy Systems**

Towards a theory of fuzzy systems 29

Outline of a new approach to the analysis of complex systems and decision processes 62

### **Part 3: Linguistic variable and approximate reasoning**

The concept of a linguistic variable and its application to approximate reasoning, I , II , III 121

### **Part 4: Fuzzy-algorithmic approach and information granularity**

A fuzzy-algorithmic approach to the definition of complex or imprecise concepts 307

Fuzzy sets and information granularity 384

Outline of a computational approach to meaning and knowledge representation based on the concept of a generalized assignment statement 412

**Part 5: Soft computing with words**

Fuzzy logic = Computing with words 435

Toward a theory of fuzzy information granulation and its  
centrality in human reasoning and fuzzy logic 461

What is soft computing? 504



# Part 1 : Fuzzy Sets



## **Fuzzy Sets**

A fuzzy set is a class of objects with a continuum of grades of membership. Such a set is characterized by a membership (characteristic) function which assigns to each object a grade of membership ranging between zero and one. The notions of inclusion, union, intersection, complement, relation, convexity, etc., are extended to such sets, and various properties of these notions in the context of fuzzy sets are established. In particular, a separation theorem for convex fuzzy sets is proved without requiring that the fuzzy sets be disjoint.

### **1. Introduction**

More often than not, the classes of objects encountered in the real physical world do not have precisely defined criteria of membership. For example, the class of animals clearly includes dogs, horses, birds, etc. as its members, and clearly excludes such objects as rocks, fluids, plants, etc. However, such objects as starfish, bacteria, etc. have an ambiguous status with respect to the class of animals. The same kind of ambiguity arises in the case of a number such as 10 in relation to the "class" of all real numbers which are much greater than 1.

Clearly, the "class of all real numbers which are much greater than 1," or "the class of beautiful women," or "the class of tall men," do not constitute classes or sets in the usual

mathematical sense of these terms. Yet, the fact remains that such imprecisely defined "classes" play an important role in human thinking, particularly in the domains of pattern recognition, communication of information, and abstraction.

The purpose of this note is to explore in a preliminary way some of the basic properties and implications of a concept which may be of use in dealing with "classes" of the type cited above. The concept in question is that of a *fuzzy set*,<sup>①</sup> that is, a "class" with a continuum of grades of membership. As will be seen in the sequel, the notion of a fuzzy set provides a convenient point of departure for the construction of a conceptual framework which parallels in many respects the framework used in the case of ordinary sets, but is more general than the latter and, potentially, may prove to have a much wider scope of applicability, particularly in the fields of pattern classification and information processing. Essentially, such a framework provides a natural way of dealing with problems in which the source of imprecision is the absence of sharply defined criteria of class membership rather than the presence of random variables.

We begin the discussion of fuzzy sets with several basic definitions.

## 2. Definitions

Let  $X$  be a space of points (objects), with a generic element

---

① An application of this concept to the formulation of a class of problems in pattern classification is described in RAND Memorandum RM-4307-PR, "Abstraction and Pattern Classification," by R. Bellman, R. Kalaba and L. A. Zadeh, October, 1964.

of  $X$  denoted by  $x$ . Thus,  $X = \{x\}$ .

A *fuzzy set (class)*  $A$  in  $X$  is characterized by a *membership (characteristic) function*  $f_A(x)$  which associates with each point<sup>①</sup> in  $X$  a real number in the interval  $[0, 1]$ <sup>②</sup>, with the value of  $f_A(x)$  at  $x$  representing the "grade of membership" of  $x$  in  $A$ . Thus, the nearer the value of  $f_A(x)$  to unity, the higher the grade of membership of  $x$  in  $A$ . When  $A$  is a set in the ordinary sense of the term, its membership function can take on only two values 0 and 1, with  $f_A(x) = 1$  or 0 according as  $x$  does or does not belong to  $A$ . Thus, in this case  $f_A(x)$  reduces to the familiar characteristic function of a set  $A$ . (When there is a need to differentiate between such sets and fuzzy sets, the sets with two-valued characteristic functions will be referred to as *ordinary sets* or simply *sets*.)

*Example.* Let  $X$  be the real line  $R^1$  and let  $A$  be a fuzzy set of numbers which are much greater than 1. Then, one can give a precise, albeit subjective, characterization of  $A$  by specifying  $f_A(x)$  as a function on  $R^1$ . Representative values of such a function might be:  $f_A(0) = 0$ ;  $f_A(1) = 0$ ;  $f_A(5) = 0.01$ ;  $f_A(10) = 0.2$ ;  $f_A(100) = 0.95$ ;  $f_A(500) = 1$ .

It should be noted that, although the membership function of a fuzzy set has some resemblance to a probability function

---

① More generally, the domain of definition of  $f_A(x)$  may be restricted to a subset of  $X$ .

② In a more general setting, the range of the membership function can be taken to be a suitable partially ordered set  $P$ . For our purposes, it is convenient and sufficient to restrict the range of  $f$  to the unit interval. If the values of  $f_A(x)$  are interpreted as truth values, the latter case corresponds to a multivalued logic with a continuum of truth values in the interval  $[0, 1]$ .

when  $X$  is a countable set (or a probability density function when  $X$  is a continuum), there are essential differences between these concepts which will become clearer in the sequel once the rules of combination of membership functions and their basic properties have been established. In fact, the notion of a fuzzy set is completely nonstatistical in nature.

We begin with several definitions involving fuzzy sets which are obvious extensions of the corresponding definitions for ordinary sets.

A fuzzy set is *empty* if and only if its membership function is identically zero on  $X$ .

Two fuzzy sets  $A$  and  $B$  are *equal*, written as  $A=B$ , if and only if  $f_A(x) = f_B(x)$  for all  $x$  in  $X$ . (In the sequel, instead of writing  $f_A(x) = f_B(x)$  for all  $x$  in  $X$ , we shall write more simply  $f_A = f_B$ .)

The *complement* of a fuzzy set  $A$  is denoted by  $A'$  and is defined by

$$f_{A'} = 1 - f_A. \quad (1)$$

As in the case of ordinary sets, the notion of containment plays a central role in the case of fuzzy sets. This notion and the related notions of union and intersection are defined as follows.

*Containment.*  $A$  is *contained in*  $B$  (or, equivalently,  $A$  is a *subset of*  $B$ , or  $A$  is *smaller than or equal to*  $B$ ) if and only if  $f_A \leq f_B$ . In symbols

$$A \subset B \Leftrightarrow f_A \leq f_B. \quad (2)$$

*Union.* The *union* of two fuzzy sets  $A$  and  $B$  with respective membership functions  $f_A(x)$  and  $f_B(x)$  is a fuzzy set  $C$ , written as  $C = A \cup B$ , whose membership function is related to those of  $A$

and  $B$  by

$$f_C(x) = \text{Max}[f_A(x), f_B(x)], \quad x \in X \quad (3)$$

or, in abbreviated form

$$f_C = f_A \vee f_B. \quad (4)$$

Note that  $\cup$  has the associative property, that is,  $A \cup (B \cup C) = (A \cup B) \cup C$ .

*Comment.* A more intuitively appealing way of defining the union is the following: The union of  $A$  and  $B$  is the smallest fuzzy set containing both  $A$  and  $B$ . More precisely, if  $D$  is any fuzzy set which contains both  $A$  and  $B$ , then it also contains the union of  $A$  and  $B$ .

To show that this definition is equivalent to (3), we note, first, that  $C$  as defined by (3) contains both  $A$  and  $B$ , since

$$\text{Max}[f_A, f_B] \geq f_A$$

and

$$\text{Max}[f_A, f_B] \geq f_B$$

Furthermore, if  $D$  is any fuzzy set containing both  $A$  and  $B$ , then

$$f_D \geq f_A$$

$$f_D \geq f_B$$

and hence

$$f_D \geq \text{Max}[f_A, f_B] = f_C$$

which implies that  $C \subset D$ . Q. E. D.

The notion of an intersection of fuzzy sets can be defined in an analogous manner. Specifically:

*Intersection.* The *intersection* of two fuzzy sets  $A$  and  $B$  with respective membership functions  $f_A(x)$  and  $f_B(x)$  is fuzzy set  $C$ , written as  $C = A \cap B$ , whose membership function is related to

those of  $A$  and  $B$  by

$$f_C(x) = \text{Min}[f_A(x), f_B(x)], \quad x \in X, \quad (5)$$

or, in abbreviated form

$$f_C = f_A \wedge f_B. \quad (6)$$

As in the case of the union, it is easy to show that the intersection of  $A$  and  $B$  is the *largest* fuzzy set which is contained in both  $A$  and  $B$ . As in the case of ordinary sets,  $A$  and  $B$  are *disjoint* if  $A \cap B$  is empty. Note that  $\cap$ , like  $\cup$ , has the associative property.

The intersection and union of two fuzzy sets in  $R^1$  are illustrated in Fig. 1. The membership function of the union is comprised of curve segments 1 and 2; that of the intersection is comprised of segments 3 and 4 (heavy lines).

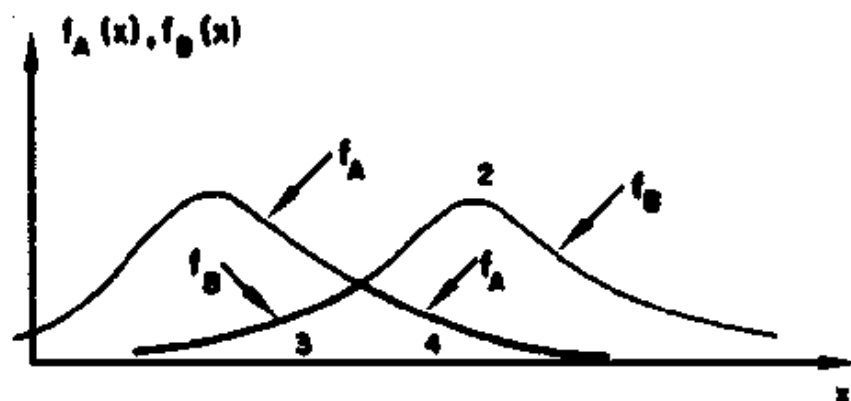

Fig. 1. Illustration of the union and intersection of fuzzy sets in  $R^1$

*Comment.* Note that the notion of "belonging," which plays fundamental role in the case of ordinary sets, does not have the same role in the case of fuzzy sets. Thus, it is not meaningful to speak of a point  $x$  "belonging" to a fuzzy set  $A$  except in the trivial sense of  $f_A(x)$  being positive. Less trivially, one can introduce two levels  $\alpha$  and  $\beta$  ( $0 < \alpha < 1, 0 < \beta < 1, \alpha > \beta$ ) and agree



to say that (1) “ $x$  belongs to  $A$ ” if  $f_A(x) \geq a$ ; (2) “ $x$  does not belong to  $A$ ” if  $f_A(x) \leq \beta$ ; and (3) “ $x$  has an indeterminate status relative to  $A$ ” if  $\beta < f_A(x) < a$ . This leads to a three-valued logic (Kleene, 1952) with three truth values;  $T(f_A(x) \geq a)$ ,  $F(f_A(x) \leq \beta)$ , and  $U(\beta < f_A(x) < a)$ .

### 3. Some properties of $\cap$ , $\cup$ , and complementation

With the operations of union, intersection, and complementation defined as in (3), (5), and (1), it is easy to extend many of the basic identities which hold for ordinary sets to fuzzy sets. As examples, we have

$$(A \cup B)' = A' \cap B' \quad (7)$$

$$(A \cap B)' = A' \cup B' \quad (8)$$

} De Morgan's laws

$$C \cap (A \cup B) = (C \cap A) \cup (C \cap B) \quad \text{Distributive laws.} \quad (9)$$

$$C \cup (A \cap B) = (C \cup A) \cap (C \cup B) \quad (10)$$

These and similar equalities can readily be established by showing that the corresponding relations for the membership functions of  $A, B$ , and  $C$  are identities. For example, in the case of (7), we have

$$1 - \text{Max}[f_A, f_B] = \text{Min}[1 - f_A, 1 - f_B] \quad (11)$$

which can be easily verified to be an identity by testing for the two possible cases;  $f_A(x) > f_B(x)$  and  $f_A(x) < f_B(x)$ .

Similarly, in the case of (10), the corresponding relation in terms of  $f_A, f_B$  and  $f_C$  is:

$$\text{Max}[f_C, \text{Min}[f_A, f_B]] = \text{Min}[\text{Max}[f_C, f_A], \text{Max}[f_C, f_B]] \quad (12)$$

which can be verified to be an identity by considering the six cases;

$$\begin{aligned}
& f_A(x) > f_B(x) > f_C(x), f_A(x) > f_C(x) > f_B(x), \\
& f_B(x) > f_A(x) > f_C(x), \\
& f_B(x) > f_C(x) > f_A(x), f_C(x) > f_A(x) > f_B(x), \\
& f_C(x) > f_B(x) > f_A(x).
\end{aligned}$$

Essentially, fuzzy sets in  $X$  constitute a distributive lattice with a 0 and 1 (Birkhoff, 1948).

#### An Interpretation for Unions and Intersections

In the case of ordinary sets, a set  $C$  which is expressed in terms of a family of sets  $A_1, \dots, A_i, \dots, A_n$  through the connectives  $\cup$  and  $\cap$ , can be represented as a network of switches  $\alpha_1, \dots, \alpha_n$ , with  $A_i \cap A_j$  and  $A_i \cup A_j$  corresponding, respectively, to series and parallel combinations of  $\alpha_i$  and  $\alpha_j$ . In the case of fuzzy sets, one can give an analogous interpretation in terms of sieves. Specifically, let  $f_i(x), i = 1, \dots, n$ , denote the value of the membership function of  $A_i$  at  $x$ . Associate with  $f_i(x)$  a sieve  $S_i(x)$  whose meshes are of size  $f_i(x)$ . Then,  $f_i(x) \vee f_j(x)$  and  $f_i(x) \wedge f_j(x)$  correspond, respectively, to parallel and series combinations of  $S_i(x)$  and  $S_j(x)$ , as shown in Fig 2.

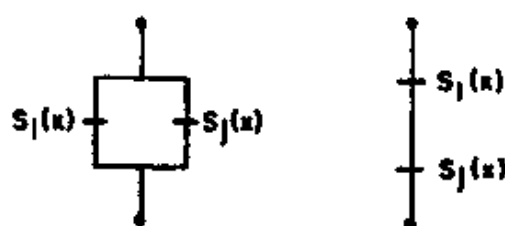

Fig. 2. Parallel and series connection of sieves simulating  $\cup$  and  $\cap$

More generally, a well-formed expression involving  $A_1, \dots, A_n, \cup$ , and  $\cap$  corresponds to a network of sieves  $S_1(x), \dots, S_n(x)$  which can be found by the conventional synthesis techniques for switching circuits. As a very simple example,

$$C = [(A_1 \cup A_2) \cap A_3] \cup A_4 \quad (13)$$

corresponds to the network shown in Fig. 3.

Note that the mesh sizes of the sieves in the network depend on  $x$  and that the network as a whole is equivalent to a single sieve whose meshes are of size  $f_C(x)$ .

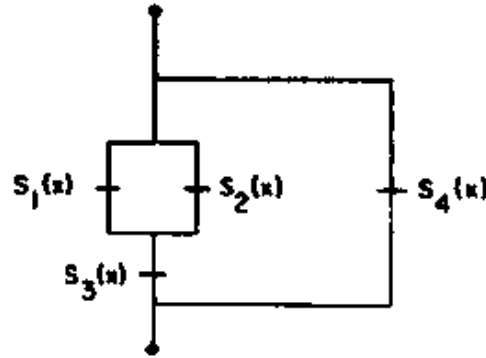

Fig. 3. A network of sieves simulating  $\{[f_1(x) \vee f_2(x)] \wedge f_3(x)\} \vee f_4(x)$

#### 4. Algebraic operations on fuzzy sets

In addition to the operations of union and intersection, one can define a number of other ways of forming combinations of fuzzy sets and relating them to one another. Among the more important of these are the following.

*Algebraic product.* The *algebraic product* of  $A$  and  $B$  is denoted by  $AB$  and is defined in terms of the membership functions of  $A$  and  $B$  by the relation

$$f_{AB} = f_A f_B \quad (14)$$

Clearly,

$$ABC \subset A \cap B. \quad (15)$$

*Algebraic sum.* ①The *algebraic sum* of  $A$  and  $B$  is denoted by  $A+B$  and is defined by ,

$$f_{A+B} = f_A + f_B \quad (16)$$

provided the sum  $f_A + f_B$  is less than or equal to unity. Thus, unlike the algebraic product, the algebraic sum is meaningful only when the condition  $f_A(x) + f_B(x) \leq 1$  is satisfied for all  $x$ .

*Absolute difference.* The *absolute difference* of  $A$  and  $B$  is denoted by  $|A-B|$  and is defined by

$$f_{|A-B|} = |f_A - f_B|.$$

Note that in the case of ordinary sets  $|A-B|$  reduces to the relative complement of  $A \cap B$  in  $A \cup B$ .

*Convex combination.* By a convex combination of two vectors  $f$  and  $g$  is usually meant a linear combination of  $f$  and  $g$  of the form  $\lambda f + (1-\lambda)g$ , in which  $0 \leq \lambda \leq 1$ . This mode of combining  $f$  and  $g$  can be generalized to fuzzy sets in the following manner.

Let  $A$ ,  $B$ , and  $\Lambda$  be arbitrary fuzzy sets. The *convex combination* of  $A$ ,  $B$ , and  $\Lambda$  is denoted by  $(A, B; \Lambda)$  and is defined by the relation

$$(A, B; \Lambda) = \Lambda A + \Lambda' B \quad (17)$$

where  $\Lambda'$  is the complement of  $\Lambda$ . Written out in terms of membership functions, (17) reads

$$f_{(A, B; \Lambda)}(x) = f_\Lambda(x) f_A(x) + [1 - f_\Lambda(x)] f_B(x), x \in X \quad (18)$$

A basic property of the convex combination of  $A$ ,  $B$ , and  $\Lambda$  is expressed by

---

① The dual of the algebraic product is the *sum*  $A \oplus B = (A' B')' = A + B - AB$ . (This was pointed out by T. Cover.) Note that for ordinary sets  $\cap$  and the algebraic product are equivalent operations, as are  $\cup$  and  $\oplus$ .

$$A \cap B \subset (A, B; \Lambda) \subset A \cup B, \text{ for all } \Lambda. \quad (19)$$

This property is an immediate consequence of the inequalities.

$$\begin{aligned} \text{Min}[f_A(x), f_B(x)] &\leq \lambda f_A(x) + (1-\lambda) f_B(x) \\ &\leq \text{Max}[f_A(x), f_B(x)], x \in X \end{aligned} \quad (20)$$

which hold for all  $\lambda$  in  $[0, 1]$ . It is of interest to observe that, given any fuzzy set  $C$  satisfying  $A \cap B \subset C \subset A \cup B$ , one can always find a fuzzy set  $A$  such that  $C = (A, B; \Lambda)$ . The membership function of this set is given by

$$f_A(x) = \frac{f_C(x) - f_B(x)}{f_C(x) - f_B(x)}, x \in X \quad (21)$$

*Fuzzy relation.* The concept of a *relation* (which is a generalization of that of a *function*) has a natural extension to fuzzy sets and plays an important role in the theory of such sets and their applications—just as it does in the case of ordinary sets. In the sequel, we shall merely define the notion of a fuzzy relation and touch upon a few related concepts.

Ordinarily, a relation is defined as a set of ordered pairs (Halmos, 1960); e. g. the set of all ordered pairs of real numbers  $x$  and  $y$  such that  $x \geq y$ . In the context of fuzzy sets, a *fuzzy relation in  $X$*  is a fuzzy set in the product space  $X \times X$ . For example, the relation denoted by  $x \gg y, x, y \in \mathbf{R}^1$ , may be regarded as a fuzzy set  $A$  in  $\mathbf{R}^2$ , with the membership function of  $A, f_A(x, y)$ , having the following (subjective) representative values;  $f_A(10, 5) = 0; f_A(100, 10) = 0.7; f_A(100, 1) = 1$ ; etc.

More generally, one can define an *n-ary fuzzy relation in  $X$*  as a fuzzy set  $A$  in the product space  $X \times X \times \cdots \times X$ . For such relations, the membership function is of the form  $f_A(x_1, \cdots, x_n)$ ,

where  $x_i \in X, i = 1, \dots, n$ .

In the case of binary fuzzy relations, the *composition* of two fuzzy relations  $A$  and  $B$  is denoted by  $B \circ A$  and is defined as a fuzzy relation in  $X$  whose membership function is related to those of  $A$  and  $B$  by

$$f_{B \circ A}(x, y) = \text{Sup}_v \text{Min}[f_A(x, v), f_B(v, y)].$$

Note that the operation of composition has the associative property

$$A \circ (B \circ C) = (A \circ B) \circ C.$$

*Fuzzy sets induced by mappings.* Let  $T$  be a mapping from  $X$  to a space  $Y$ . Let  $B$  be a fuzzy set in  $Y$  with membership function  $f_B(y)$ . The inverse mapping  $T^{-1}$  induces a fuzzy set  $A$  in  $X$  whose membership function is defined by

$$f_A(x) = f_B(y), y \in Y \quad (22)$$

for all  $x$  in  $X$  which are mapped by  $T$  into  $y$ .

Consider now a converse problem in which  $A$  is a given fuzzy set in  $X$ , and  $T$ , as before, is a mapping from  $X$  to  $Y$ . The question is: What is the membership function for the fuzzy set  $B$  in  $Y$  which is induced by this mapping?

If  $T$  is not one-one, then an ambiguity arises when two or more distinct points in  $X$ , say  $x_1$  and  $x_2$ , with different grades of membership in  $A$ , are mapped into the same point  $y$  in  $Y$ . In this case, the question is: What grade of membership in  $B$  should be assigned to  $y$ ?

To resolve this ambiguity, we agree to assign the larger of the two grades of membership to  $y$ . More generally, the membership function for  $B$  will be defined by

$$f_B(y) = \text{Max}_{x \in T^{-1}(y)} f_A(x), y \in Y \quad (23)$$

where  $T^{-1}(y)$  is the set of points in  $X$  which are mapped into  $y$  by  $T$ .

### 5. Convexity

As will be seen in the sequel, the notion of convexity can readily be extended to fuzzy sets in such a way as to preserve many of the properties which it has in the context of ordinary sets. This notion seems to be particularly useful in applications involving pattern classification, optimization and related problems.

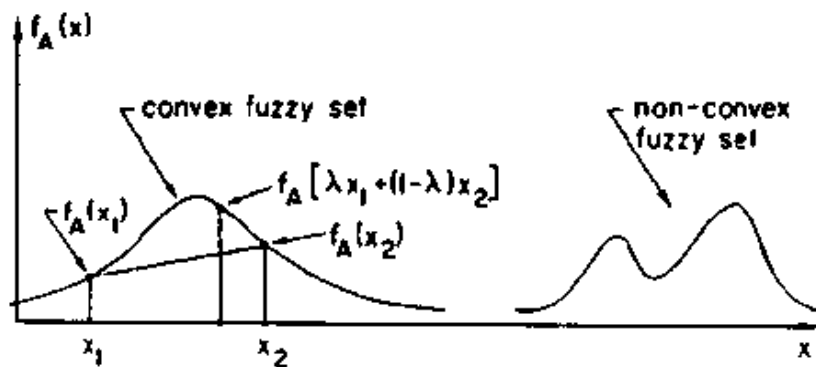

Fig. 4. Convex and nonconvex fuzzy sets in  $E^1$

In What follows, we assume for concreteness that  $X$  is a real Euclidean space  $E^n$ .

#### Definitions

*Convexity.* A fuzzy set  $A$  is *convex* if and only if the sets  $\Gamma_\alpha$  defined by

$$\Gamma_\alpha = \{x \mid f_A(x) \geq \alpha\} \quad (24)$$

are convex for all  $\alpha$  in the interval  $(0, 1]$ .

An alternative and more direct definition of convexity is the following<sup>①</sup>:  $A$  is *convex* if and only if

$$f_A[\lambda x_1 + (1-\lambda)x_2] \geq \text{Min}[f_A(x_1), f_A(x_2)] \quad (25)$$

for all  $x_1$  and  $x_2$  in  $X$  and all  $\lambda$  in  $[0,1]$ . Note that this definition does not imply that  $f_A(x)$  must be a convex function of  $x$ . This is illustrated in Fig. 4 for  $n=1$ .

To show the equivalence between the above definitions note that if  $A$  is convex in the sense of the first definition and  $\alpha = f_A(x_1) \leq f_A(x_2)$ , then  $x_2 \in \Gamma_\alpha$  and  $\lambda x_1 + (1-\lambda)x_2 \in \Gamma_\alpha$  by the convexity of  $\Gamma_\alpha$ . Hence

$$f_A[\lambda x_1 + (1-\lambda)x_2] \geq \alpha = f_A(x_1) = \text{Min}[f_A(x_1), f_A(x_2)].$$

Conversely, if  $A$  is convex in the sense of the second definition and  $\alpha = f_A(x_1)$ , then  $\Gamma_\alpha$  may be regarded as the set of all points  $x_2$  for which  $f_A(x_2) \geq f_A(x_1)$ . In virtue of (25), every point of the form  $\lambda x_1 + (1-\lambda)x_2, 0 \leq \lambda \leq 1$ , is also in  $\Gamma_\alpha$  and hence  $\Gamma_\alpha$  is a convex set. Q. E. D.

A basic property of convex fuzzy sets is expressed by the Theorem. *If  $A$  and  $B$  are convex, so is their intersection.*

*Proof:* Let  $C = A \cap B$ . Then

$$\begin{aligned} f_C[\lambda x_1 + (1-\lambda)x_2] \\ = \text{Min}[f_A[\lambda x_1 + (1-\lambda)x_2], f_B[\lambda x_1 + (1-\lambda)x_2]]. \end{aligned} \quad (26)$$

Now, since  $A$  and  $B$  are convex

$$\begin{aligned} f_A[\lambda x_1 + (1-\lambda)x_2] &\geq \text{Min}[f_A(x_1), f_A(x_2)] \\ f_B[\lambda x_1 + (1-\lambda)x_2] &\geq \text{Min}[f_B(x_1), f_B(x_2)] \end{aligned} \quad (27)$$

---

① This way of expressing convexity was suggested to the writer by his colleague, E. Berlekamp.



and hence

$$\begin{aligned} f_c[\lambda x_1 + (1-\lambda)x_2] \\ \geq \text{Min}[\text{Min}[f_A(x_1), f_B(x_2)], \text{Min}[f_B(x_1), f_B(x_2)]] \end{aligned} \quad (28)$$

or equivalently

$$\begin{aligned} f_c[\lambda x_1 + (1-\lambda)x_2] \\ \geq \text{Min}[\text{Min}[f_A(x_1), f_B(x_1)], \text{Min}[f_A(x_2), f_B(x_2)]] \end{aligned} \quad (29)$$

and thus

$$f_c[\lambda x_1 + (1-\lambda)x_2] \geq \text{Min}[f_c(x_1), f_c(x_2)] \quad \text{Q. E. D.} \quad (30)$$

*Boundedness.* A fuzzy set  $A$  is *bounded* if and only if the sets  $\Gamma_\alpha = \{x \mid f_A(x) \geq \alpha\}$  are bounded for all  $\alpha > 0$ ; that is, for every  $\alpha > 0$  there exists a finite  $R(\alpha)$  such that  $\|x\| \leq R(\alpha)$  for all  $x$  in  $\Gamma_\alpha$ .

If  $A$  is a bounded set, then for each  $\epsilon > 0$  there exists a hyperplane  $H$  such that  $f_A(x) \leq \epsilon$  for all  $x$  on the side of  $H$  which does not contain the origin. For, consider the set  $\Gamma_\epsilon = \{x \mid f_A(x) \geq \epsilon\}$ . By hypothesis, this set is contained in a sphere  $S$  of radius  $R(\epsilon)$ . Let  $H$  be any hyper-plane supporting  $S$ . Then, all points on the side of  $H$  which does not contain the origin lie outside or on  $S$ , and hence for all such points  $f_A(x) \leq \epsilon$ .

*Lemma.* Let  $A$  be a bounded fuzzy set and let  $M = \text{Sup}_x f_A(x)$ . ( $M$  will be referred to as the maximal graded in  $A$ .) Then there is at least one point  $x_n$  contains points in the set  $Q(\epsilon) = \{x \mid f_A(x) \geq M - \epsilon\}$ .

*Proof.* <sup>①</sup> Consider a nested sequence of bounded sets  $\Gamma_1, \Gamma_2, \dots$ , where  $\Gamma_n = \{x \mid f_A(x) \geq M - M/(n+1)\}$ ,  $n = 1, 2, \dots$ . Note that

---

① This proof was suggested by A. J. Thomasian.

$\Gamma_n$  is nonempty for all finite  $n$  as a consequence of the definition of  $M$  as  $M = \text{Sup}_x f_A(x)$ . (We assume that  $M > 0$ .)

Let  $x_n$  be an arbitrarily chosen point in  $\Gamma_n, n=1, 2, \dots$ . Then,  $x_1, x_2, \dots$ , is a sequence of points in a closed bounded set  $\Gamma_1$ . By the Bolzano-Weierstrass theorem, this sequence must have at least one limit point, say  $x_0$ , in  $\Gamma_1$ . Consequently, every spherical neighborhood of  $x_0$  will contain infinitely many points from the sequence  $x_1, x_2, \dots$ , and, more particularly, from the subsequence  $x_{N+1}, x_{N+2}, \dots$ , where  $N \geq M/\epsilon$ . Since the points of this subsequence fall within the set  $Q(\epsilon) = \{x \mid f_A(x) \geq M - \epsilon\}$ , the lemma is proved.

*Strict and strong convexity.* A fuzzy set  $A$  is *strictly convex* if the sets  $\Gamma_\alpha, 0 < \alpha \leq 1$  are strictly convex (that is, if the midpoint of any two distinct points in  $\Gamma_\alpha$  lies in the interior of  $\Gamma_\alpha$ ). Note that this definition reduces to that of strict convexity for ordinary sets when  $A$  is such a set.

A fuzzy set  $A$  is *strongly convex* if, for any two distinct points  $x_1$  and  $x_2$ , and any  $\lambda$  in the open interval  $(0, 1)$

$$f_A[\lambda x_1 + (1-\lambda)x_2] > \text{Min}[f_A(x_1), f_A(x_2)].$$

Note that strong convexity does not imply strict convexity or vice-versa. Note also that if  $A$  and  $B$  are bounded, so is their union and intersection. Similarly, if  $A$  and  $B$  are strictly (strongly) convex, their intersection is strictly (strongly) convex.

Let  $A$  be a convex fuzzy set and let  $M = \text{Sup}_x f_A(x)$ . If  $A$  is bounded, then, as shown above, either  $M$  is attained for some  $x$ , say  $x_0$ , or there is at least one point  $x_0$  at which  $M$  is essentially attained in the sense that, for each  $\epsilon > 0$ , every spherical neighborhood of  $x_0$  contains points in the set  $Q(\epsilon) = \{x \mid M - \epsilon < f_A(x) < M\}$ .

$(x) \leq \epsilon$ . In particular, if  $A$  is strongly convex and  $x_0$  is attained, then  $x_0$  is unique. For, if  $M = f_A(x_0)$  and  $M = f_A(x_1)$ , with  $x_1 \neq x_0$ , then  $f_A(x) > M$  for  $x = 0.5x_0 + 0.5x_1$ , which contradicts  $M = \text{Max}_x f_A(x)$ .

More generally, let  $C(A)$  be the set of all points in  $X$  at which  $M$  is essentially attained. This set will be referred to as the *core* of  $A$ . In the case of convex fuzzy sets, we can assert the following property of  $C(A)$ .

**Theorem.** *If  $A$  is a convex fuzzy set, then its core is a convex set.*

*Proof:* It will suffice to show that if  $M$  is essentially attained at  $x_0$  and  $x_1, x_1 \neq x_0$ , then it is also essentially attained at all  $x$  of the form  $x = \lambda x_0 + (1 - \lambda)x_1, 0 \leq \lambda \leq 1$ .

To the end, let  $P$  be a cylinder of radius  $\epsilon$  with the line passing through  $x_0$  and  $x_1$  as its axis. Let  $x_0'$  be a point in a sphere of radius  $\epsilon$  centering on  $x_0$  and  $x_1'$  be a point in a sphere of radius  $\epsilon$  centering on  $x_1$  such that  $f_A(x_0') \geq M - \epsilon$  and  $f_A(x_1') \geq M - \epsilon$ . Then, by the convexity of  $A$ , for any point  $u$  on the segment  $x_0'x_1'$ , we have  $f_A(u) \geq M - \epsilon$ . Furthermore, by the convexity of  $P$ , all points on  $x_0'x_1'$  will lie in  $P$ .

Now let  $x$  be any point in the segment  $x_0x_1$ . The distance of this point from the segment  $x_0'x_1'$  must be less than or equal to  $\epsilon$ , since  $x_0'x_1'$  must be less than or equal to  $\epsilon$ , since  $x_0'x_1'$  lies in  $P$ . Consequently, a sphere of radius  $\epsilon$  centering on  $x$  will contain at least one point of the segment  $x_0'x_1'$  and hence will contain at least one point, say  $w$ , at which  $f_A(w) \geq M - \epsilon$ . This establishes that  $M$  is essentially attained at  $x$  and thus proves the theorem.

**Corollary.** *If  $X = E^1$  and  $A$  is strongly convex, then the point*

at which  $M$  is essentially attained is unique.

*Shadow of a fuzzy set.* Let  $A$  be a fuzzy set in  $E^n$  with membership function  $f_A(x) = f_A(x_1, \dots, x_n)$ . For notational simplicity, the notion of the shadow (projection) of  $A$  on a hyperplane  $H$  will be defined below for the special case where  $H$  is a coordinate hyperplane, e. g.,  $H = \{x \mid x_1 = 0\}$ .

Specifically, the shadow of  $A$  on  $H = \{x \mid x_1 = 0\}$  is defined to be a fuzzy set  $S_H(A)$  in  $E^{n-1}$  with  $f_{S_H(A)}(x)$  given by

$$f_{S_H(A)}(x) = f_{S_H(A)}(x_2, \dots, x_n) = \sup_{x_1} f_A(x_1, \dots, x_n).$$

Note that this definition is consistent with (23).

When  $A$  is a convex fuzzy set, the following property of  $S_H(A)$  is an immediate consequence of the above definition: If  $A$  is a convex fuzzy set, then its shadow on any hyperplane is also a convex fuzzy set.

An interesting property of the shadows of two convex fuzzy sets is expressed by the following implication

$$S_H(A) = S_H(B), \text{ for all } H \Rightarrow A = B.$$

To prove this assertion, <sup>①</sup> it is sufficient to show that if there exists a point, say  $x_0$ , such that  $f_A(x_0) \neq f_B(x_0)$ , then there exists a hyperplane  $H$  such that  $f_{S_H(A)}(x_0^*) \neq f_{S_H(B)}(x_0^*)$ , where  $x_0^*$  is the projection of  $x_0$  on  $H$ .

Suppose that  $f_A(x_0) = \alpha > f_B(x_0) = \beta$ . Since  $B$  is a convex fuzzy set, the set  $\Gamma_\beta = \{x \mid f_B(x) > \beta\}$  is convex, and hence there exists a hyper-plane  $F$  supporting  $\Gamma_\beta$  and passing through  $x_0$ . Let  $H$  be a hyperplane orthogonal to  $F$ , and let  $x_0^*$  be the projection

---

① This proof is based on an idea suggested by G. Dantzig for the case where  $A$  and  $B$  are ordinary convex sets.

of  $x_0$  on  $H$ . Then, since  $f_H(x) \leq \beta$  for all  $x$  on  $F$ , we have  $f_{S_H(A)}(x_0) \leq \beta$ . On the other hand,  $f_{S_H(A)}(x_0) \geq \alpha$ . Consequently,  $f_{S_H(B)}(x_0) \neq f_{S_H(A)}(x_0)$ , and similarly for the case where  $\alpha < \beta$ .

A somewhat more general form of the above assertion is the following: Let  $A$ , but not necessarily  $B$ , be a convex fuzzy set, and let  $S_H(A) = S_H(B)$  for all  $H$ . Then  $A = \text{conv } B$ , where  $\text{conv } B$  is the convex hull of  $B$ , that is, the smallest, convex set containing  $B$ . More generally,  $S_H(A) = S_H(B)$  for all  $H$  implies  $\text{conv } A = \text{conv } B$ .

*Separation of convex fuzzy sets.* The classical separation theorem for ordinary convex sets states, in essence, that if  $A$  and  $B$  are disjoint convex sets, then there exists a separating hyperplane  $H$  such that  $A$  is on one side of  $H$  and  $B$  is on the other side.

It is natural to inquire if this theorem can be extended to convex fuzzy sets, without requiring that  $A$  and  $B$  be disjoint, since the condition of disjointness is much too restrictive in the case of fuzzy sets. It turns out, as will be seen in the sequel, that the answer to this question is in the affirmative.

As a preliminary, we shall have to make a few definitions. Specifically, let  $A$  and  $B$  be two bounded fuzzy sets and let  $H$  be a hypersurface in  $E^n$  defined by an equation  $h(x) = 0$ , with all points for which  $h(x) \geq 0$  being on one side of  $H$  and all points for which  $h(x) \leq 0$  being on the other side. <sup>(1)</sup> Let  $K_H$  be a number dependent on  $H$  such that  $f_A(x) \leq K_H$  on one side of  $H$  and  $f_B(x) \leq K_H$  on the other side. Let  $M_H$  be  $\text{Inf } K_H$ . The number  $D_H =$

---

(1) Note that the sets in question have  $H$  in common.

$1 - M_H$  will be called the *degree of separation of A and B by H*.

In general, one is concerned not with a given hypersurface  $H$ , but with a family of hypersurfaces  $\{H_\lambda\}$ , with  $\lambda$  ranging over, say,  $E^m$ . The problem, then, is to find a member of this family which realizes the highest possible degree of separation.

A special case of this problem is one where the  $H_\lambda$  are hyperplanes in  $E^n$ , with  $\lambda$  ranging over  $E^n$ . In this case, we define the *degree of separability of A and B* by the relation

$$D = 1 - \bar{M} \quad (31)$$

where

$$\bar{M} = \text{Inf}_H M_H \quad (32)$$

with the subscript  $\lambda$  omitted for simplicity.

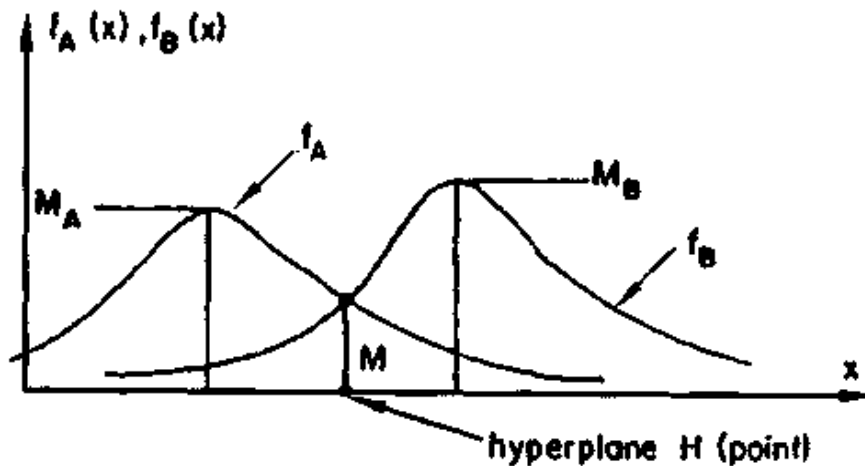

Fig. 5. Illustration of the separation theorem for fuzzy sets in  $E^1$

Among the various assertions that can be made concerning  $D$ , the following statement<sup>①</sup> is, in effect, an extension of the separation theorem to convex fuzzy sets.

*Theorem. Let A and B be bounded convex fuzzy sets in  $E^n$ ,*

① This statement is based on a suggestion of E. Berlekamp.

with maximal grades  $M_A$  and  $M_B$ , respectively [ $M_A = \sup_x f_A(x)$ ,  $M_B = \sup_x f_B(x)$ ]. Let  $M$  be the maximal grade for the intersection  $A \cap B$  ( $M = \sup_x \text{Min}[f_A(x), f_B(x)]$ ). Then  $D = 1 - M$ .

*Comment.* In plain words, the theorem states that the highest degree of separation of two convex fuzzy sets  $A$  and  $B$  that can be achieved with a hyperplane in  $E^n$  is one minus the maximal grade in the intersection  $A \cap B$ . This is illustrated in Fig. 5 for  $n = 1$ .

*Proof:* It is convenient to consider separately the following two cases: (1)  $M = \text{Min}(M_A, M_B)$  and (2)  $M < \text{Min}(M_A, M_B)$ . Note that the latter case rules out  $A \subset B$  or  $B \subset A$ .

*Case 1.* For concreteness, assume that  $M_A < M_B$ , so that  $M = M_A$ . Then, by the property of bounded sets already stated there exists a hyperplane  $H$  such that  $f_B(x) \leq M$  for all  $x$  on one side of  $H$ . On the other side of  $H$ ,  $f_A(x) \leq M$  because  $f_A(x) \leq M_A = M$  for all  $x$ .

It remains to be shown that there do not exist an  $M' < M$  and a hyperplane  $H'$  such that  $f_A(x) \leq M'$  on one side of  $H'$  and  $f_B(x) \leq M'$  on the other side.

This follows at once from the following observation. Suppose that such  $H'$  and  $M'$  exist, and assume for concreteness that the core of  $A$  (that is, the set of points at which  $M_A = M$  is essentially attained) is on the plus side of  $H'$ . This rules out the possibility that  $f_A(x) \leq M'$  for all  $x$  on the plus side of  $H'$ , and hence necessitates that  $f_A(x) \leq M'$  for all  $x$  on the minus side of  $H'$ , and  $f_B(x) \leq M'$  for all  $x$  on the plus side of  $H'$ . Consequently, over all  $x$  on the plus side of  $H'$

$$\text{Sup}_x \text{Min}[f_A(x), f_B(x)] \leq M'$$

and likewise for all  $x$  on the minus side of  $H'$ . This implies that,

over all  $x$  in  $X$ ,  $\sup_x \text{Min}[f_A(x), f_B(x)] \leq M'$ , which contradicts the assumption that  $\sup_x \text{Min}[f_A(x), f_B(x)] = M > M'$ .

*Case 2.* Consider the convex sets  $\Gamma_A = \{x \mid f_A(x) > M\}$  and  $\Gamma_B = \{x \mid f_B(x) > M\}$ . These sets are nonempty and disjoint, for if they were not there would be a point, say  $u$ , such that  $f_A(u) > M$  and  $f_B(u) > M$ , and hence  $f_{A \cap B}(u) > M$ , which contradicts the assumption that  $M = \sup_x f_{A \cap B}(x)$ .

Since  $\Gamma_A$  and  $\Gamma_B$  are disjoint, by the separation theorem for ordinary convex sets there exists a hyperplane  $H$  such that  $\Gamma_A$  is on one side of  $H$  (say, the plus side) and  $\Gamma_B$  is on the other side (the minus side). Furthermore, by the definitions of  $\Gamma_A$  and  $\Gamma_B$ , for all points on the minus side of  $H$ ,  $f_A(x) \leq M$ , and for all points on the plus side of  $H$ ,  $f_B(x) \leq M$ .

Thus, we have shown that there exists a hyperplane  $H$  which realizes  $1 - M$  as the degree of separation of  $A$  and  $B$ . The conclusion that a higher degree of separation of  $A$  and  $B$  cannot be realized follows from the argument given in Case 1. This concludes the proof of the theorem.

The separation theorem for convex fuzzy sets appears to be of particular relevance to the problem of pattern discrimination. Its application to this class of problems as well as to problems of optimization will be explored in subsequent notes on fuzzy sets and their properties.



## References

- Birkhoff, G. (1948), "Lattice Theory," Am. Math. Soc. Colloq. Publ., Vol. 25, New York.
- Halmos, P. R. (1960), "Naive Set Theory," Van Nostrand, New York.
- Kleene, S. C. (1952), "Introduction to Metamathematics," P. 334. Van Nostrand, New York.



## Part 2: Fuzzy Systems



# **Toward a Theory of Fuzzy Systems**

## **Introduction**

Many of the advances in network theory and system theory during the past three decades are traceable to the influence and contributions of Ernst Guiliemin, Norbert Wiener, Richard Bellman, Rudolph Kalman, and their students. In sum, we now possess an impressive armamentarium of techniques for the analysis and synthesis of linear and nonlinear systems of various types — techniques that are particularly effective in dealing with systems characterized by ordinary differential or difference equations of moderately high order such as those encountered in network theory, control theory, and related fields.

What we still lack, and lack rather acutely, are methods for dealing with systems which are too complex or too ill-defined to admit of precise analysis. Such systems pervade life sciences, social sciences, philosophy, economics, psychology and many other “soft” fields. Furthermore, they are encountered in what are normally regarded as “nonsoft” fields when the complexity of a system rules out the possibility of analyzing it by conventional mathematical means, whether with or without the aid of computers. Many examples of such systems are found among large-scale traffic control systems, pattern-recognition systems, machine translators, large-scale information-processing systems,

Large-scale power-distribution networks, neural networks, and games such as chess and checkers.

Perhaps the major reason for the ineffectiveness of classical mathematical techniques in dealing with systems of high order of complexity lies in their failure to come to grips with the issue of fuzziness, that is, with imprecision that stems not from randomness but from a lack of sharp transition from membership in a class to nonmembership in it. It is this type of imprecision that arises when one speaks, for example, of the class of real numbers much larger than 10, since the real numbers can not be divided dichotomously into those that are much larger than 10 and those that are not. The same applies to classes such as "tall men," "good strategies for playing chess," "pairs of numbers that are approximately equal to one another," "systems that are approximately linear," and so forth. Actually, most of the classes encountered in the real world are of this fuzzy, imprecisely defined kind. What sets such classes apart from classes that are well-defined in the conventional mathematical sense is the fuzziness of their boundaries. In effect, in the case of a class with a fuzzy boundary, an object may have a grade of membership in it that lies somewhere between full membership and nonmembership.

A class that admits of the possibility of partial membership in it is called a fuzzy set.<sup>[1]</sup> In this sense, the class of tall men, for example, is a fuzzy set, as is the class of real numbers that are much larger than 10. We make a *fuzzy statement* or assertion when some of the words appearing in the statement or assertion in question are names for fuzzy sets. This is true, for example, of

such statements as "John is *tall*," "*x* is *approximately* equal to 5," "*y* is *much larger than* 10." In these statements, the sources of fuzziness are the italicized words, which, in effect, are labels for fuzzy sets.

Why is fuzziness so relevant to complexity? Because no matter what the nature of a system is, when its complexity exceeds a certain threshold it becomes impractical or computationally infeasible to make precise assertions about it. For example, in the case of chess the size of the decision tree is so large that it is impossible, in general, to find a precise algorithmic solution to the following problem: Given the position of pieces on the board, determine an optimal next move. Similarly, in the case of a large-scale traffic-control system, the complexity of the system precludes the possibility of precise evaluation of its performance. Thus, any significant assertion about the performance of such a system must necessarily be fuzzy in nature, with the degree of fuzziness increasing with the complexity of the system.

How can fuzziness be made a part of system theory? A tentative step in this direction was taken in recent papers<sup>[2][3]</sup> in which the notions of a fuzzy system<sup>①</sup> and fuzzy algorithm were introduced. In what follows, we shall proceed somewhat further in this direction, focusing our attention on the definition of a fuzzy system and its state. It should be emphasized, however, that the task of constructing a complete theory of fuzzy systems is one

---

① The maximin automata of Wee and Santos<sup>[4][5]</sup> may be regarded as instances of fuzzy systems.

of very considerable magnitude, and that what we shall have to say about fuzzy systems in the sequel is merely a first step toward devising a conceptual framework for dealing with such systems in both qualitative and quantitative ways.

### Elementary properties of fuzzy sets

The concept of a fuzzy system is intimately related to that of a fuzzy set. In order to make our discussion self-contained, it will be helpful to begin with a brief summary of some of the basic definitions pertaining to such sets. <sup>①</sup>

#### Definition of a Fuzzy Set

Let  $X = \{x\}$  denote a space of points (objects), with  $x$  denoting a generic element of  $X$ . Then a *fuzzy set*  $A$  in  $X$  is a set of ordered pairs

$$A = \{[x, \mu_A(x)]\} \quad x \in X \quad (1)$$

where  $\mu_A(x)$  is termed the *grade of membership* of  $x$  in  $A$ . Thus, if  $\mu_A(x)$  takes values in a space  $M$ —termed the *membership space*—then  $A$  is essentially a function from  $X$  to  $M$ . The function  $\mu_A: X \rightarrow M$ , which defines  $A$ , is called the *membership function* of  $A$ . When  $M$  contains only two points 0 and 1,  $A$  is nonfuzzy and its membership function reduces to the conventional characteristic function of a nonfuzzy set.

Intuitively, a fuzzy set  $A$  in  $X$  is a class without sharply defined boundaries—that is, a class in which a point (object)  $x$  may have a grade of membership intermediate between full

---

<sup>①</sup> More detailed discussions of fuzzy sets and their properties may be found in the references listed at the end of this chapter.



membership and nonmembership. The important point to note is that such a fuzzy set can be defined *precisely* by associating with each  $x$  its grade of membership in  $A$ . In what follows, we shall assume for simplicity that  $M$  is the interval  $[0, 1]$ , with the grades 0 and 1 representing, respectively, nonmembership and full membership in a fuzzy set. (More generally,  $M$  can be a partially ordered set or, more particularly, a lattice.<sup>[6]</sup>) Thus, our basic assumption will be that a fuzzy set  $A$  in  $X$ , though lacking in sharply defined boundaries, can be precisely characterized by a membership function that associates with each  $x$  in  $X$  a number in the interval  $[0, 1]$  representing the grade of membership of  $x$  in  $A$ .

*Example*

Let  $A = \{x \mid x \gg 1\}$  (that is,  $A$  is the fuzzy set of real numbers that are much larger than 1). Such a set may be defined subjectively by a membership function such as:

$$\begin{aligned} \mu_A(x) &= 0 && \text{for } x \leq 1 \\ &= [1 + (x-1)^{-2}]^{-1} && \text{for } x > 1 \end{aligned} \quad (2)$$

It is important to note that in the case of a fuzzy set it is not meaningful to speak of an object as belonging or not belonging to that set, except for objects whose grade of membership in the set is unity or zero. Thus, if  $A$  is the fuzzy set of tall men, then the statement "John is tall" should not be interpreted as meaning that John belongs to  $A$ . Rather, such a statement should be interpreted as an association of John with the fuzzy set  $A$ --an association which will be denoted by  $\text{John} \underset{\sim}{\in} A$  to distinguish it from an assertion of belonging in the usual nonfuzzy sense-- that

is,  $\text{John} \in A$ , which is meaningful only when  $A$  is nonfuzzy. ①

### Containment

Let  $A$  and  $B$  be fuzzy sets in  $X$ . Then  $A$  is contained in  $B$  (or  $A$  is a subset of  $B$ ) written as  $A \subset B$ , if and only if  $\mu_A(x) \leq \mu_B(x)$  for all  $x$  in  $X$ . (In the sequel, to simplify the notation we shall omit  $x$  when an equality or inequality holds for all values of  $x$  in  $X$ .)

### Example

If  $\mu_A = \mu_B^2$ , then  $A \subset B$ .

### Equality

Two fuzzy sets are equal, written as  $A = B$ , if and only if  $\mu_A = \mu_B$ .

### Complementation

A fuzzy set  $A'$  is the complement of a fuzzy set  $A$  if and only if  $\mu_{A'} = 1 - \mu_A$ .

### Example

The fuzzy sets  $A = \{x | x \gg 1\}$  and  $A' = \{x | x \text{ not } \gg 1\}$  are complements of one another.

### Union

The union of  $A$  and  $B$  is denoted by  $A \cup B$  and is defined as the smallest fuzzy set containing both  $A$  and  $B$ . The membership function of  $A \cup B$  is given by  $\mu_{A \cup B} = \text{Max}[\mu_A, \mu_B]$ . Thus, if at a point  $x$ ,  $\mu_A(x) = 0.9$ , say, and  $\mu_B(x) = 0.4$ , then at that point  $\mu_{A \cup B}(x) = 0.9$ .

---

① Here and elsewhere in this chapter we shall employ the convention of underscoring a symbol with a wavy bar to represent a fuzzified version of the meaning of that symbol. For example,  $x \underline{=} y$  will denote a fuzzy equality of  $x \Rightarrow y$  will denote fuzzy implication, etc.

As in the case of nonfuzzy sets, the notion of the union is closely related to that of the connective "or". Thus, if  $A$  is a class of tall men,  $B$  is a class of fat men and "John is tall" or "John is fat," then John is associated with the union of  $A$  and  $B$ . More generally, expressed in symbols we have

$$\underline{x \in A} \quad \text{or} \quad \underline{x \in B} \Rightarrow \underline{x \in A \cup B} \quad (3)$$

#### *Intersection*

The *intersection* of  $A$  and  $B$  is denoted by  $A \cap B$  and is defined as the largest fuzzy set contained in both  $A$  and  $B$ . The membership function of  $A \cap B$  is given by  $\mu_{A \cap B} = \text{Min}[\mu_A, \mu_B]$ . It is easy to verify that  $A \cap B = (A' \cup B')'$ . The relation between the connective "and" and  $\cap$  is expressed by

$$\underline{x \in A} \quad \text{and} \quad \underline{x \in B} \Rightarrow \underline{x \in A \cap B} \quad (4)$$

#### *Algebraic Product*

The *algebraic product* of  $A$  and  $B$  is denoted by  $AB$  and is defined by  $\mu_{AB} = \mu_A \mu_B$ . Note that the product distributes over the union but not vice-versa.

#### *Algebraic Sum*

The *algebraic sum* of  $A$  and  $B$  is denoted by  $A \oplus B$  and is defined by  $\mu_{A \oplus B} = \mu_A + \mu_B - \mu_{AB}$ . It is trivial to verify that  $A \oplus B = (A' B')'$ .

#### *Relation*

A *fuzzy relation*,  $R$ , in the product space  $X \times Y = \{(x, y)\}$ ,  $x \in X, y \in Y$ , is a fuzzy set in  $X \times Y$  characterized by a membership function  $\mu_R$  that associates with each ordered pair  $(x, y)$  a grade of membership  $\mu_R(x, y)$  in  $R$ . More generally, an  $n$ -ary fuzzy relation in a product space  $X = X^1 \times X^2 \times \dots \times X^n$  is a fuzzy set in  $X$  characterized by an  $n$ -variate membership function  $\mu_R(x_1, \dots,$

$x_i), x_i \in X^i$ , for  $i = 1, \dots, n$ .

*Example*

Let  $X = R \times R$ , where  $R$  is the real line  $(-\infty, \infty)$ . Then  $x \gg y$  is a fuzzy relation in  $R^2$ . A subjective expression for  $\mu_R$  in this case might be

$$\begin{aligned} \mu_R(x, y) &= 0 \quad \text{for } x \leq y \\ \mu_R(x, y) &= \left[ 1 + \left( 1 - \frac{x}{y} \right)^{-2} \right]^{-1} \quad \text{for } x > y \end{aligned}$$

*Composition of Relations*

If  $R_1$  and  $R_2$  are two fuzzy relations in  $X^2$ , then by the composition of  $R_1$  and  $R_2$  is meant a fuzzy relation in  $X^2$  which is denoted by  $R_1 \circ R_2$  and is defined by

$$\mu_{R_1 \circ R_2}(x, y) = \text{Sup}_v \text{Min}[R_1(x, v), R_2(v, y)] \quad (5)$$

where the supremum is taken over all  $v$  in  $X$ .

*Fuzzy Sets Induced by Mappings*

Let  $f: X \rightarrow Y$  be a mapping from  $X$  to  $Y$ , with the image of  $x$  under  $f$  denoted by  $y = f(x)$ . Let  $A$  be a fuzzy set in  $X$ . Then the mapping  $f$  induces a fuzzy set  $B$  in  $Y$  whose membership function is given by

$$\mu_B(y) = \text{Sup}_{x \in f^{-1}(y)} \mu_A(x) \quad (6)$$

where  $f^{-1}(y)$  denotes the set of points in  $X$  which are mapped by  $f$  into  $y$ .

*Shadow of a Fuzzy Set*

Let  $A$  be a fuzzy set in  $X \times Y$ , and let  $f$  denote the mapping that takes  $(x, y)$  into  $x$ . The fuzzy set in  $X$  that is induced by this mapping is called the shadow<sup>[7]</sup> (projection) of  $A$  on  $X$  and is denoted by  $S_X(A)$ . In consequence of (6), the membership function of  $S_X(A)$  is given by

$$\mu_{S_X(A)}(x) = \text{Sup}_y \mu_A(x, y) \quad (7)$$

where  $\mu_A(x, y)$  is the membership function of  $A$ .

#### *Conditioned Fuzzy Sets*

A fuzzy set  $B(x)$  in  $Y$  will be said to be *conditioned on  $x$*  if its membership function depends on  $x$  as a parameter. To place this dependence in evidence, we shall denote the membership function of  $B(x)$  as  $\mu_B(y|x)$ , or—when  $B$  can be omitted with no risk of confusion—as  $\mu(y|x)$ .

Now suppose that the parameter  $x$  ranges over a space  $X$ . Then, the function  $\mu_B(y|x)$  defines a mapping from  $X$  to the space of fuzzy sets defined on  $Y$ . Through this mapping, a fuzzy set  $A$  in  $X$  induces a fuzzy set  $B$  in  $Y$ , which is defined by

$$\mu_B(y) = \sup_{x \in X} \min[\mu_A(x), \mu_B(y|x)] \quad (8)$$

where  $\mu_A$  and  $\mu_B$  denote the membership functions of  $A$  and  $B$ , respectively. In effect, (8) is a special case of the composition of relations (5).

The notion of a conditioned fuzzy set bears some resemblance to the notion of a conditional probability distribution. Thus, (8) is the counterpart of the familiar identity

$$p_B(y) = \int_X p_B(y|x) p_A(x) dx \quad (9)$$

where, for simplicity,  $x$  and  $y$  are assumed to be real-valued.  $p_{A(x)}$  denotes the probability density of  $x$ ,  $p_B(y|x)$  denotes the conditional probability density of  $y$  given  $x$  and  $p_B(y)$  denotes the probability density of  $y$ .<sup>①</sup> It is worthy of note that, in this as

---

① To simplify the notation, we use the same symbol to denote a random variable and a generic value of that variable.

well as many other instances involving fuzziness on the one hand and probability on the other, the corresponding formulas differ from one another in that to the operations of summation and integration involving probabilities corresponds the operation of taking the supremum (or maximum) of membership functions, and to the operation of multiplication of probabilities corresponds the operation of taking the infimum (or minimum) of membership functions. To make this correspondence more evident, it is convenient to use the symbols  $\vee$  and  $\wedge$  for the supremum and infimum, respectively. Then, (9) becomes

$$\mu_B(y) = \vee_x [\mu_A(x) \wedge \mu_B(y|x)] \quad (10)$$

Similarly, (7) becomes

$$\mu_B(y) = \vee_{x \in f^{-1}(y)} \mu_A(x) \quad (11)$$

for which its probabilistic counterpart reads

$$p_B(y) = \sum_{x \in f^{-1}(y)} p_A(x) \quad (12)$$

where  $x$  and  $y$  are assumed to range over finite sets and  $p_A(x)$  and  $p_B(y)$  denote probabilities rather than probability densities as in (9).

This concludes our brief summary of some of the basic concepts relating to fuzzy sets. In what follows, we shall employ these concepts in defining a fuzzy system and explore some of the elementary properties of such systems.

### **System, aggregate and state**

For simplicity, we shall restrict our attention to time-invariant discrete-time systems in which  $t$ , time, ranges over integres, and the input and output at time  $t$  are real-valued.

In the theory of nonfuzzy discrete-time systems, it is customary to introduce the notion of state at the very outset by defining a system  $A$  through its state equations:

$$\begin{aligned}x_{t+1} &= f(x_t, u_t) \quad t = \dots, -1, 0, 1, \dots \\y_t &= g(x_t, u_t)\end{aligned}\tag{13}$$

where  $u_t$  denotes the *input* at time  $t$ ,  $y_t$  is the *output* at time  $t$  and  $x_t$  is the *state* at time  $t$ , with the ranges of  $u_t$ ,  $y_t$ , and  $x_t$  denoted by  $U$ ,  $Y$  and  $X$ , respectively. In this way,  $A$  is characterized by two mappings,  $f : X \times U \rightarrow X$  and  $g : X \times U \rightarrow Y$ . The space  $X$  is called the *state space* of  $A$ , and a point  $\alpha$  in  $X$  is called a *state* of  $A$ .

Let  $u$  denote an input sequence starting at, say,  $t=0$ . Thus,  $u = u_0 u_1 \dots u_l$ , where  $u_t \in U$ ,  $t = 0, 1, \dots, l$ , and  $l$  is a nonnegative integer. The set of all sequences whose elements are drawn from  $U$  will be denoted by  $U^*$ .

Now, to each state  $\alpha$  in  $X$  and each input sequence  $u = u_0 u_1 \dots u_l$  in  $U^*$  will correspond an output sequence  $y = y_0 y_1 \dots y_l$  in  $Y^*$ . The pair of sequences  $(u, y)$  is called an *input-output* pair of length  $l+1$ . The totality of input-output pairs  $(u, y)$  of varying lengths that correspond to a particular state  $\alpha$  in  $X$  will be referred to as an *aggregate* of input-output pairs, or simply an *aggregate*,  $A(\alpha)$ , with  $\alpha$  playing the role of a label for this aggregate. The union

$$A = \bigcup_{\alpha \in X} A(\alpha)$$

represents the totality of input-output pairs that correspond to all the states of  $A$ . It is this totality of input-output pairs that we shall equate with  $A$ .

The fact that a state is merely a label for an aggregate suggests that the concept of an aggregate be accorded a central

place among the basic concepts of system theory. This is done implicitly in Refs. [8] and [9], and explicitly in [10]. The point of departure in the theory developed in Ref. [8] is the definition of a system as a collection of input-output pairs. An aggregate, then, may be defined as a subset of input-output pairs which satisfy certain consistency conditions, with a state playing the role of a name for an aggregate.

In what follows, we shall first generalize to fuzzy systems the conventional approach in which a system is described through its state equations. Then we shall indicate a connection between the notion of a fuzzy algorithm and a fuzzy system. Finally, we shall present in a summary form some of the basic definitions relating to the notion of an aggregate and briefly touch upon their generalization to fuzzy systems.

### State equations for fuzzy systems

Let  $u_t$ ,  $y_t$ , and  $x_t$  denote, respectively, the input, output and state of a system  $A$  at time  $t$ . Such a system is said to be *deterministic* if it is characterized by state equations of the form

$$\dot{x}_{t+1} = f(x_t, u_t) \quad t = -1, 0, 1, 2, \dots \quad (14)$$

$$y_t = g(x_t, u_t) \quad (15)$$

in which  $f$  and  $g$  are mappings from  $X \times U$  to  $X$  and  $Y$ , respectively.

$A$  is said to be *nondeterministic* if  $x_{t+1}$  and/or  $y_t$  are not uniquely determined by  $x_t$  and  $u_t$ . Let  $X^{t+1}(x_t, u_t)$  and  $Y^t(x_t, u_t)$  or  $X^{t+1}$  and  $Y^t$ , for short, denote the sets of possible values of  $x_{t+1}$  and  $y_t$ , respectively, given  $x_t$  and  $u_t$ . Then (14) and (15) can be replaced by equations of the form



$$X^{t+1} = F(x_t, u_t) \quad (16)$$

$$Y^t = G(x_t, u_t) \quad (17)$$

where  $F$  and  $G$  are mappings from  $X \times U$  into the space of subsets of  $X$  and  $Y$ , respectively. Thus, a nondeterministic system is characterized by equations of the form (16) and (17), in which  $X^{t+1}$  and  $Y^t$  are subsets of  $X$  and  $Y$ , respectively.

The next step in the direction of further generalization is to assume that  $X^{t+1}$  and  $Y^t$  are fuzzy rather than nonfuzzy sets in  $X$  and  $Y$ , respectively. In this case, we shall say that  $A$  is a *fuzzy discrete-time system*. Clearly, such a system reduces to a nondeterministic system when  $X^{t+1}$  and  $Y^t$  are nonfuzzy sets. In turn, a nondeterministic system reduces to a deterministic system when  $X^{t+1}$  and  $Y^t$  are single points (singletons) in their respective spaces.

Let  $\mu_X(x_{t+1} | x_t, u_t)$  and  $\mu_Y(y_t | x_t, u_t)$  denote the membership functions of  $X^{t+1}$  and  $Y^t$ , respectively, given  $x_t$  and  $u_t$ . Then we can say that  $A$  is *characterized* by the two membership functions  $\mu_X(x_{t+1} | x_t, u_t)$  and  $\mu_Y(y_t | x_t, u_t)$ , which define conditioned fuzzy sets in  $X$  and  $Y$ , respectively, involving  $x_t$  and  $u_t$  as parameters.

To illustrate, suppose that  $X = \mathbf{R}^3$ . Then  $A$  is a fuzzy system if its characterization contains statements such as: "If an input  $u_t = 5$  is applied to  $A$  in state  $x_t = (3, 5, 1)$  at time  $t$ , then the state of  $A$  at time  $t+1$  will be in the *vicinity* of the point  $(7, 3, 5)$ ." Here the set of points in  $X$  that lie in the vicinity of a given point  $\alpha$  is a fuzzy set in  $X$ . Such a set may be characterized by a membership function such as

$$\mu(x) = \exp\left(-\frac{1}{k} \|x - \alpha\|\right) \quad (18)$$

where  $x$  is a point in  $X$ ,  $\|x - a\|$  denotes a norm of the vector  $x - a$ , and  $k$  is a positive constant.

By analogy with nonfuzzy systems, a fuzzy system  $A$  will be said to be *memoryless* if the fuzzy set  $Y^t$  is independent of  $x_t$ —that is, if its membership function is of the form  $\mu_Y(y_t | u_t)$ . Just as a nonfuzzy memoryless system is characterized by a graph  $y_t = g(u_t)$ ,  $u_t \in U$ , so a fuzzy memoryless system is characterized by a fuzzy graph that is a family of fuzzy sets  $\{Y^t(u_t), u_t \in U\}$ .

In the case of a memoryless system, to each point  $u_t$  in  $U$  corresponds a fuzzy set  $Y^t(u_t)$  or  $Y^t$  for short, in  $Y$ . Thus, we can write

$$Y^t = G(u_t) \quad t = \dots, -1, 0, 1, 2, \dots \quad (19)$$

where  $G$  is a function from  $R^1$  to the space of fuzzy sets in  $Y$ . Now as a consequence of equation (8), this implies that if  $U^t$  is a fuzzy set in  $U$  characterized by a membership function  $\mu_U(u_t)$ , then to  $U^t$  will correspond the fuzzy set  $Y^t$  defined by the membership function

$$\mu_Y(y_t) = \bigvee_{u_t} (\mu_U(u_t) \wedge \mu_Y(y_t | u_t)) \quad (20)$$

where  $\bigvee$  and  $\wedge$  denote the supremum and minimum, respectively. Thus, (20) establishes a relation between  $U^t$  and  $Y^t$  which can be expressed as

$$Y^t = G_0(U^t) \quad t = \dots, -1, 0, 1, 2, \dots \quad (21)$$

where  $G_0$  is a function from the space of fuzzy sets in  $U$  to the space of fuzzy sets in  $Y$ .

The important point to be noted here is that equation (19), which expresses  $Y^t$  as a function of  $u_t$ , induces equation (21), which expresses  $Y^t$  as a function of  $U^t$ . As should be expected,

(21) reduces to (19) when  $U'$  is taken to be the singleton  $\{u_t\}$ .

Intuitively, equations (19) and (21) may be interpreted as follows. If  $A$  is a fuzzy memoryless system, then to every nonfuzzy input  $u_t$  at time  $t$  corresponds a unique fuzzy output, which is represented by a conditioned fuzzy set  $Y'$  in  $Y$ . The membership function of this fuzzy set is given by  $\mu_Y(y_t | u_t)$ .

If the input to  $A$  is fuzzy—that is, if it is a fuzzy set  $U'$  in  $U$ —then the corresponding fuzzy output  $Y'$  is given uniquely by (21). The membership function for  $Y'$  is expressed by (20).

As a very simple example, suppose that  $U$  and  $Y$  are finite sets;  $U = \{1, 2, 3\}$  and  $Y = \{1, 2, 3\}$ . Furthermore, suppose that if the input  $u_t$  is 1, then the output is a fuzzy set described verbally as “ $y_t$  is approximately equal to 1.” Similarly, if  $u_t = 2$  then  $y_t$  is approximately equal to 2, and if  $u_t = 3$  then  $y_t$  is approximately equal to 3. More concretely, we assume that  $\mu_Y(y_t | u_t)$  is defined by the table:

$$\begin{array}{lll} \mu_Y(1|1) = 1 & \mu_Y(2|1) = 0.3 & \mu_Y(3|1) = 0.1 \\ \mu_Y(1|2) = 0.2 & \mu_Y(2|2) = 1 & \mu_Y(3|2) = 0.2 \\ \mu_Y(1|3) = 0.1 & \mu_Y(2|3) = 0.2 & \mu_Y(3|3) = 1 \end{array}$$

Now assume that the input is a fuzzy set described verbally as “ $u_t$  is close to 1,” and characterized by the membership function

$$\mu_U(1) = 1 \quad \mu_U(2) = 0.2 \quad \mu_U(3) = 0.1$$

Then, by using (20), the response to this fuzzy input is found to be a fuzzy set defined by the membership function

$$\mu_Y(1) = 1 \quad \mu_Y(2) = 0.2 \quad \mu_Y(3) = 0.2$$

It is convenient to regard (21) as a mapping from names of fuzzy sets in  $U$  to names of fuzzy sets in  $Y$ . In many cases of practical interest such a mapping can be adequately characterized

by a finite, and perhaps even fairly small, number of points [ordered pairs  $(U, Y)$ ] on the graph of  $G_0$ . For example,  $G_0$  might be characterized approximately by a table such as shown below. (For simplicity we suppress the subscript  $t$  in  $u_t$  and  $y_t$ )

$U'$	$Y'$
1	1
1.1	1.3
1.2	1.6
1.3	2
1.4	2.5
1.5	2.9
1.6	2.5
1.7	2.1
1.8	1.8
1.9	1.6
2	1.5
2.1	1.5
•	•
•	•
•	•
3	1.5

where  $\tilde{x}, x \in \mathbf{R}$ , is the name for the fuzzy set of real numbers that are approximately equal to  $x$ . Such a set may be characterized quantitatively by a membership function. In many practical situations a very approximate description of this membership function would be sufficient. In this way, equation (21) can serve the purpose of an approximate characterization of a fuzzy memoryless system.

Turning to nonmemoryless fuzzy systems, consider a system

$A$  which is characterized by state equations of the form

$$X^{t+1} = F(x_t, u_t) \quad (22)$$

$$Y^t = G(x_t, u_t) \quad (23)$$

where  $F$  is a function from the product space  $X \times U$  to the space of fuzzy sets in  $X$ ,  $G$  is a function from  $X \times U$  to the space of fuzzy sets in  $Y$ ,  $X^{t+1}$  denotes a fuzzy set in  $X$  that is conditioned on  $x_t$  and  $u_t$ , and  $Y^t$  denotes a fuzzy set in  $Y$  that, like  $X^{t+1}$ , is conditioned on  $x_t$  and  $u_t$ .  $X^t$  and  $Y^t$  represent, respectively, the fuzzy state and output of  $A$  at time  $t$  and are defined by the membership functions  $\mu_X(x_{t+1} | x_t, u_t)$  and  $\mu_Y(y_t | x_t, u_t)$ .

Equations (22) and (23) relate the fuzzy state at time  $t+1$  and the fuzzy output at time  $t$  to the nonfuzzy state and nonfuzzy input at time  $t$ . As in the case of a memoryless system, we can deduce from these equations—by repeated application of (8)—the state equations for  $A$  for the case where the state at time  $t$  or the input at time  $t$ , or both, are fuzzy.

Specifically, let us assume that the state at time  $t$  is a fuzzy set characterized by a membership function  $\mu_X(x_t)$ . Then, by applying (8), we deduce from (22) and (23)

$$\mu_X(x_{t+1}) = \bigvee_{x_t} (\mu_X(x_t) \wedge \mu_X(x_{t+1} | x_t, u_t)) \quad (24)$$

$$\mu_Y(y_t) = \bigvee_{x_t} (\mu_X(x_t) \wedge \mu_Y(y_t | x_t, u_t)) \quad (25)$$

which in symbolic form may be expressed as

$$X^{t+1} = F_0(X^t, u_t) \quad (26)$$

$$Y^t = G_0(X^t, u_t) \quad (27)$$

In what follows, to simplify the appearance of equations such as (24) and (25) we shall omit the subscripts  $X$  and  $Y$  in membership functions.

By  $n$ -fold iteration of (26) and (27), we can obtain expressions for  $X^{t+n+1}$  and  $Y^{t+n}$ , for  $n = 1, 2, 3, \dots$ , in terms of  $X^t$  and  $u_t, \dots, u_{t+n}$ . For example, for  $n = 1$ , we have

$$X^{t+2} = F_0(F_0(X^t, u_t), u_{t+1}) \quad (28)$$

$$Y^{t+1} = G_0(F_0(X^t, u_t), u_{t+1}) \quad (29)$$

or, more compactly,

$$X^{t+2} = F_1(X^t, u_t, u_{t+1}) \quad (30)$$

$$Y^{t+1} = G_1(X^t, u_t, u_{t+1}) \quad (31)$$

To express (30) and (31) in terms of membership functions, we note that on replacing  $t$  with  $t+1$  in (24) and (25), we obtain

$$\mu(x_{t+2}) = \bigvee_{x_{t+1}} (\mu(x_{t+1}) \wedge \mu(x_{t+2} | x_{t+1}, u_{t+1})) \quad (32)$$

$$\mu(y_{t+1}) = \bigvee_{x_{t+1}} (\mu(x_{t+1}) \wedge \mu(y_{t+1} | x_{t+1}, u_{t+1})) \quad (33)$$

Then, on substituting  $\mu(x_{t+1})$  from (24) into (32) and (33), we get

$$\mu(x_{t+2}) = \bigvee_{x_{t+1}} (\bigvee_{x_t} (\mu(x_t) \wedge \mu(x_{t+1} | x_t, u_t)) \wedge \mu(x_{t+2} | x_{t+1}, u_{t+1})) \quad (34)$$

and

$$\mu(y_{t+1}) = \bigvee_{x_{t+1}} (\bigvee_{x_t} (\mu(x_t) \wedge \mu(x_{t+1} | x_t, u_t)) \wedge \mu(y_{t+1} | x_{t+1}, u_{t+1})) \quad (35)$$

which by virtue of the distributivity of  $\bigvee$  and  $\wedge$  may be expressed as

$$\mu(x_{t+2}) = \bigvee_{x_{t+1}} \bigvee_{x_t} (\mu(x_t) \wedge \mu(x_{t+1} | x_t, u_t) \wedge \mu(x_{t+2} | x_{t+1}, u_{t+1})) \quad (36)$$

$$\mu(y_{t+1}) = \bigvee_{x_{t+1}} \bigvee_{x_t} (\mu(x_t) \wedge \mu(x_{t+1}|x_t, u_t) \wedge \mu(y_{t+1}|x_{t+1}, u_{t+1})) \quad (37)$$

and likewise for larger values of  $n$ . It should be noted that these relations are fuzzy counterparts of the corresponding expressions for stochastic systems,<sup>[11]</sup> with  $\wedge$  and  $\bigvee$  replacing product and sum, respectively, and membership functions replacing probability functions [see (19) and the equations following it].

In the above analysis, we have assumed that the successive inputs  $u_t, \dots, u_{t+n}$  are nonfuzzy. On this basis, we can obtain expressions for  $X^{t+1}, \dots, X^{t+n+1}$  and  $Y^t, \dots, Y^{t+n}$  in terms of  $X^t$  and  $u_t, \dots, u_{t+n}$ . It is natural to raise the question of what the corresponding expressions for  $X^{t+1}, \dots, X^{t+n+1}$  and  $Y^t, \dots, Y^{t+n}$  are when the successive inputs are fuzzy.

First, let us focus our attention on the state equations (16) and (17), in which  $F$  and  $G$  are functions from  $X \times U$  to fuzzy sets in  $X$  and  $Y$ , respectively. Suppose that both the input at time  $t$  and the state at time  $t$  are fuzzy. What would be the expressions for the membership functions of  $X^{t+1}$  and  $Y^t$  in this simple case?

Let  $\mu(x_t, u_t)$  denote the membership function of the fuzzy set whose elements are ordered pairs  $(x_t, u_t)$ .<sup>①</sup> Then, using equation (8) we can express the membership functions of  $X^{t+1}$  and  $Y^t$  as follows:

$$\mu(x_{t+1}) = \bigvee_{x_t} \bigvee_u (\mu(x_t, u) \wedge \mu(x_{t+1}|x_t, u)) \quad (38)$$

$$\mu(y_t) = \bigvee_{x_t} \bigvee_u (\mu(x_t, u) \wedge \mu(y_t|x_t, u)) \quad (39)$$

---

① The probabilistic counterpart of this membership function is the joint probability of  $x$  and  $u$ .

These formulas assume a simpler form when  $\mu(x_t, u_t)$  can be expressed as

$$\mu(x_t, u_t) = \mu(x_t) \wedge \mu(u_t) \quad (40)$$

where  $\mu(x_t)$  and  $\mu(u_t)$  denote, respectively, the membership functions of the fuzzy state and the fuzzy input at time  $t$ . In this case, we shall say that the fuzzy sets  $X'$  and  $U'$  are *noninteracting*. Essentially, the notion of noninteraction of fuzzy sets corresponds to the notion of independence of random variables.

The assumption that  $X'$  and  $U'$  are noninteracting fuzzy sets is a reasonable one to make in many cases of practical interest. Under this assumption, (38) and (39) reduce to

$$\mu(x_{t+1}) = \bigvee_{x_t} \bigvee_{u_t} (\mu(x_t) \wedge \mu(u_t) \wedge \mu(x_{t+1} | x_t, u_t)) \quad (41)$$

$$\mu(y_t) = \bigvee_{x_t} \bigvee_{u_t} (\mu(x_t) \wedge \mu(u_t) \wedge \mu(y_t | x_t, u_t)) \quad (42)$$

It should be noted that the same expressions can be obtained by applying (8) to (26) and (27), with the input at time  $t$  assumed to be a fuzzy set characterized by  $\mu(u_t)$ .

In symbolic form, (41) and (42) can be expressed as

$$X^{t+1} = F_{00}(X^t, U^t) \quad (43)$$

$$Y^t = G_{00}(X^t, U^t) \quad (44)$$

where  $F_{00}$  and  $G_{00}$  are, respectively, functions from the product space of fuzzy sets in  $X$  and  $U$  to the space of fuzzy sets in  $X$  and fuzzy sets in  $Y$ . Thus, equation (43) expresses the fuzzy state at time  $t+1$  as a function of the fuzzy state at time  $t$  and the fuzzy input at time  $t$ . Similarly, equation (44) expresses the fuzzy output at time  $t$  as a function of the fuzzy state at time  $t$  and the fuzzy input at time  $t$ . Note that (43) is induced via (8) by (22), which expresses the fuzzy state at time  $t+1$  as a function of the



nonfuzzy state at time  $t$  and the nonfuzzy input at time  $t$ . The same is true of (44) and (23).

When  $X, U$  and  $Y$  are finite sets, the above equations can be written more compactly by expressing the membership functions in matrix or vector form. Specifically, suppose that  $X$ , for example, is a finite set  $X = \{x^1, \dots, x^m\}$ . For each input  $u_t$ , let  $M(u_t)$  denote a matrix whose  $(i, j)$ th element is given by

$$M_{ij}(u_t) = \mu(x^i | x^j, u_t)$$

Also, let  $\bar{x}_{t+1}$  and  $\bar{x}_t$  be column vectors whose  $i$ th elements are  $\mu(x_{t+1}^i)$  and  $\mu(x_t^i)$ , respectively, evaluated at  $x_{t+1}$  and  $x_t$  equal to  $x^i, i = 1, \dots, m$ . Then, (24) and (25) may be written in matrix form as

$$\bar{x}_{t+1} = M(u_t) \bar{x}_t$$

where the right-hand member should be interpreted as the matrix product of  $M(u_t)$  and  $\bar{x}_t$ , with  $+$  replaced by  $\vee$  and product by  $\wedge$ . Similarly, (36) and (37) become

$$\begin{aligned} \bar{x}_{t+2} &= M(u_{t+1}) M(u_t) \bar{x}_t \\ \bar{y}_{t+1} &= M_Y(u_{t+1}) M(u_t) \bar{x}_t \end{aligned}$$

where  $M_Y(u_{t+1})$  is defined in the same way as  $M(u_t)$ , with  $y_{t+1}$  replacing  $x_{t+1}$  in the definition of the latter, and likewise for  $\bar{y}_{t+1}$ . More generally, for  $n = 1, 2, \dots$ , we can write

$$\begin{aligned} \bar{x}_{t+n+1} &= M(u_{t+n}) \cdots M(u_t) \bar{x}_t \\ \bar{y}_{t+n} &= M_Y(u_{t+n}) M(u_{t+n-1}) \cdots M(u_t) \bar{x}_t \end{aligned}$$

When both  $x_t$  and  $u_t$  are fuzzy, we can no longer employ the matrix notation to simplify expressions such as (24) and (25). However, some notational simplification, particularly in the case of expressions like (36) and (37), may be achieved by the use of the tensor notation or the notation commonly employed in

dealing with bilinear forms.

A simple numerical example will serve to illustrate the use of the formulas derived above. Specifically, let us consider a fuzzy system with binary input and output,  $U = Y = \{0, 1\}$ , and finite state space  $X = \{\alpha, \beta, \gamma\}$ . Suppose that the membership functions  $\mu(x_{t+1} | x_t, u_t)$  and  $\mu(y_t | x_t, u_t)$  for this system are characterized by the following tables

$\mu(x_{t+1} | x_t, U_t):$

		$u_t = 0$			$u_t = 1$		
		$\alpha$	$\beta$	$\gamma$	$\alpha$	$\beta$	$\gamma$
$x_t$	$\alpha$	1	0.8	0.6	0.8	0.5	1
	$\beta$	0.7	0.2	1	0.2	1	0.6
	$\gamma$	0.3	0.3	0.4	0.9	0.7	1

$\mu(y_t | x_t, u_t):$

		$u_t = 0$		$u_t = 1$	
		0	1	0	1
$x_t$	$\alpha$	0.8	0.3	0.6	0.3
	$\beta$	1	0.1	0.5	1
	$\gamma$	0.8	0.7	0.3	0.2

Further, assume that  $X'$  and  $U'$  are characterized by the membership functions

$$\mu(\alpha) = 1 \quad \mu(\beta) = 0.8 \quad \mu(\gamma) = 0.4 \quad \mu(0) = 1 \quad \mu(1) = 0.3$$

Then, using (41) and (42) and employing matrix multiplication (with the operation  $\vee$  and  $\wedge$  replacing sum and product), we can readily compute the values of the membership



sets in their respective spaces.

So far, we have restricted our attention to the case where a single fuzzy input  $U^t$  is applied to  $A$  in state  $X^t$ . For this case, we found expressions for  $X^{t+1}$  and  $Y^t$  in terms of  $X^t$  and  $U^t$ . The same approach can readily be extended, however, to the case in which the input is a sequence of noninteracting fuzzy inputs  $U^t U^{t+1} \dots U^{t+n}$ , for  $n \geq 1$ . The assumption of noninteraction implies that

$$\mu(u_t, \dots, u_{t+n}) = \mu(u_t) \wedge \mu(u_{t+1}) \wedge \dots \wedge \mu(u_{t+n}) \quad (45)$$

To illustrate, let  $n=1$ . Then by applying (8) to (36) and (37), we obtain

$$\begin{aligned} \mu(x_{t+2}) = \bigvee_{x_{t+1}} \bigvee_{x_t} \bigvee_{u_t} \bigvee_{u_{t+1}} & (\mu(x_t) \wedge \mu(x_{t+1} | x_t, u_t) \\ & \wedge \mu(x_{t+2} | x_{t+1}, u_{t+1}) \wedge \mu(\mu_t) \wedge \mu(\mu_{t+1})) \end{aligned} \quad (46)$$

$$\begin{aligned} \mu(y_{t+1}) = \bigvee_{x_{t+1}} \bigvee_{x_t} \bigvee_{u_t} \bigvee_{u_{t+1}} & (\mu(x_t) \wedge \mu(x_{t+1} | x_t, u_t) \\ & \wedge \mu(y_{t+1} | x_{t+1}, u_{t+1}) \wedge \mu(\mu_t) \wedge \mu(\mu_{t+1})) \end{aligned} \quad (47)$$

As in the case of (36) and (37), for higher values of  $n$  such relations can be expressed more compactly through the use of vector and tensor notation. For our purposes, the simple case  $n=1$  considered above suffices to illustrate the main features of the method which can be used to compute the fuzzy state and fuzzy output of a system at the end of a finite sequence of noninteracting fuzzy inputs.

### Fuzzy systems and fuzzy algorithms

As was shown in a recent note,<sup>[3]</sup> the notion of a fuzzy system bears a close relation to that of a fuzzy algorithm.

Roughly speaking, a fuzzy algorithm is an algorithm in which some of the instructions are fuzzy in nature. Examples of

such instructions are: (a) Increase  $x$  *slightly* if  $y$  is *slightly* larger than 10; (b) Decrease  $u$  until it becomes *much smaller* than  $v$ ; (c) *Reduce* speed if the road is *slippery*. The sources of fuzziness in these instructions are the underlined words.

More generally, we may view a fuzzy algorithm as a fuzzy system  $A$  characterized by equations of the form:

$$X^{t+1} = F(X^t, U^t) \quad (48)$$

$$U^t = H(X^t) \quad (49)$$

where  $X^t$  is a fuzzy state of  $A$  at time  $t$ ,  $U^t$  is a fuzzy input (representing a fuzzy instruction) at time  $t$ , and  $X^{t+1}$  is the fuzzy state at time  $t + 1$  resulting from the execution of the fuzzy instruction represented by  $U^t$ . As seen from (48) and (49), the function  $F$  defines the dependence of the fuzzy state at time  $t + 1$  on the fuzzy state at time  $t$  and the fuzzy input at time  $t$ , whereas the function  $H$  describes the dependence of the fuzzy input at time  $t$  on the fuzzy state at time  $t$ .

To illustrate (48) and (49), we shall consider a very simple example. Suppose that  $X$  is a fuzzy subset of a finite set  $X = \{\alpha_1, \alpha_2, \alpha_3, \alpha_4\}$  and  $U$  is a fuzzy subset of a finite set  $U = \{\beta_1, \beta_2\}$ . Since the membership functions of  $X$  and  $U$  are mappings from, respectively,  $X$  and  $U$  to the unit interval, these functions can be represented as points in unit hypercubes in  $R^4$  and  $R^2$ , which we shall denote for convenience by  $C^4$  and  $C^2$ . Thus,  $E$  may be defined by a mapping from  $C^4 \times C^2$  to  $C^4$  and  $H$  by a mapping from  $C^4$  to  $C^2$ . For example, if the membership function of  $X$  is represented by the vector  $(0.5, 0.8, 1, 0.6)$  and that of  $U$  by the vector  $(1, 0.2)$ , then the membership function of  $X^{t+1}$  would be defined by  $F$  as a vector—say  $(0.2, 1, 0.8, 0.4)$ ,—whereas that

of  $U'$  would be defined by  $H$  as a vector  $(0.3, 1)$ , say.

It is clear that even in the very simple case where  $X$  and  $U$  are small finite sets, it is impracticable to attempt to characterize  $F$  with any degree of precision as a mapping from a product of unit hypercubes to a unit hypercube. Thus, in general, it would be necessary to resort to an approximate definition of  $F$  and  $H$  through the process of exemplification, as was done in the case of the relation between  $Y'$  and  $U'$  in the previous section 9; see (21) and subsequent equations. This amounts to selecting a finite number of sample fuzzy sets in  $X$  and  $U$ , and tabulating finite approximations to  $F$  and  $H$  as mappings from and to the names of these fuzzy sets. In this light, an instruction such as "Reduce speed if the road is slippery" may be viewed as an ordered pair in  $H$  involving the names of fuzzy sets: "Reduce speed" and "Road is slippery."

Consider now the following situation. One is given an instruction of the form: "If  $x$  is much larger than 1 make  $y$  equal to 2. Otherwise make  $y$  equal to 1." Furthermore, the membership function of the class of numbers that are much larger than 1 is specified to be

$$\begin{aligned} \mu_E(x) &= 0 && \text{for } x < 1 \\ &= [1 + (x-1)^{-2}]^{-1} && \text{for } x \geq 1 \end{aligned} \quad (50)$$

where  $E$  denotes the class in question and  $\mu_E$  is its membership function.

Now suppose that  $x = 3$ . How should the above instruction be executed? Note that  $\mu_E(3) = 0.8$ .

The answer to this question is that the given instruction does not cover this contingency or, for that matter, any situation

in which  $x$  is a number such that  $\mu_E(x) > 0$ . Specifically, the instruction in question tells us only that if the input is a fuzzy set characterized by the membership function (50), then  $y=2$ ; and if the input is characterized by the membership function  $1-\mu_E(x)$ , then  $y=1$ . Now when  $x$  is specified to be equal to 3, the input may be regarded as a fuzzy set whose membership function is equal to 1 for  $x=3$  and vanishes elsewhere. This fuzzy set is not in the domain of the instruction—if we view the instruction as a function defined on a collection of fuzzy sets.

In some cases, it may be permissible to extend the domain of definition of a fuzzy instruction by an appropriate interpretation of its intent. For example, in the case considered above it may be reasonable to assume that  $y=2$  not just for the fuzzy set of numbers that are much larger than 1, but also for all fuzzy subsets of this set whose maximal grade of membership exceeds or is equal to a prescribed threshold; or, it may be reasonable to assume that  $y=2$  for all  $x$  whose grade of membership in  $E$  is greater than or equal to a threshold  $\alpha$ . Alternatively, the domain of the instruction can be extended by employing randomized execution—that is, by choosing  $y=2$  and  $y=1$  for a given  $x$  with probabilities  $\mu_E(x)$  and  $1-\mu_E(x)$ , respectively. These and other ways of extending the domain of fuzzy instructions make the specification of  $F$  and  $H$  a problem that, though nontrivial, is well within the range of computational feasibility in many cases of practical interest.

Actually, crude forms of fuzzy algorithms are employed quite extensively in everyday practice. A food recipe is an example of an algorithm of this type. So is the set of instructions for parking

a car or repairing a TV set. The effectiveness of such algorithms depends in large measure on the existence of a fuzzy feedback which makes it possible to observe the output and apply a corrective input. Indeed, this is implicit in equation (50), except that in practice the  $H$  function is itself quite ill-defined.

The foregoing discussion of the notion of a fuzzy algorithm was intended primarily to point to a close connection between this notion and that of a fuzzy system. It may well turn out, however, that many of the complex problems (such as machine translation of languages) than so far have eluded all attempts to solve them by conventional techniques cannot be properly formulated, much less solved, without the use, in one form or another, of a broader conceptual framework in which the notion of a fuzzy algorithm plays a basic role.

### **The concept of aggregate**

As was pointed out in a previous section, the state of a system may be viewed as a name for an aggregate of input-output pairs. In what follows, we shall summarize some of the principal notions relating to the concept of an aggregate, but will leave open the question of how these notions can be extended to fuzzy systems.

As in that section, let  $u$  and  $y$  denote a pair of sequences  $u = u_0 u_1 \cdots u_t$  and  $y = y_0 y_1 \cdots y_t$  of length  $t+1$ , where, for simplicity,  $t$  is assumed to range over nonnegative integers. If  $u = u_0 u_1 \cdots u_r$  and  $v = v_{r+1} \cdots v_t$ , then the concatenation of  $u$  and  $v$  is denoted by  $uv$  and is defined by  $uv = u_0 v_1 \cdots u_r v_{r+1} \cdots v_t$ .

#### **Definition of a System**



A system (*discrete-time system*)  $A$  is defined as a collection of ordered pairs of time functions  $(u, y)$  satisfying the condition of *closure under segmentation*, or CUS for short. Thus

$$A = \{(u, y) \mid u \in U^*, y \in Y^*\},$$

where  $u$  and  $y$  are, respectively, the *input* and *output* of  $A$ , and  $(u, y)$  is an *input-output pair* belonging to  $A$ . The expression for the CUS condition is:

If  $u = vv'$  and  $y = ww'$  (that is,  $u$  is a concatenation of time functions  $v$  and  $v'$ , and  $y$  is a concatenation of  $w$  and  $w'$ ) and  $(u, y) \in A$ , then  $(v, w) \in A$  and  $(v', w') \in A$ . In effect, this condition requires that every segment of an input-output pair of  $A$  be an input-output pair of  $A$ .

*Comment*

When we define a system as a collection of input-output pairs, we are in effect identifying a physical system or a mathematical model of it with the totality of observations that can be made of its input and output time functions. Furthermore, we tacitly assume that we have as many copies of the system as there are different initial states, and that each  $u$  is applied to all these copies, so that to each  $u$  correspond as many  $y$ 's as there are copies of the system.

To characterize  $A$  as a collection of input-output pairs it is usually more expedient to employ an algorithm for generating input-output pairs belonging to  $A$  than to list them. From this point of view, a differential or difference equation relating the output of a system to its input may be viewed as a compact way of specifying the collection of input-output pairs that defines  $A$ . An algorithm or an equation that serves this purpose is called an

*input-output relation.*

#### Definition of an Aggregate

Let  $A(t_0)$  denote a subset of  $A$  comprising those input-output pairs that start at time  $t_0$ . Now suppose we group together those input-output pairs in  $A(t_0)$  that have some property in common, and call such groups *bundles* of input-output pairs. As we shall see presently, the *aggregates* of  $A$  are bundles of input-output pairs with certain special properties, defined in such a way as to make a state of  $A$  merely a name or a label for an aggregate of  $A$ .

It is convenient to state the properties in question as a set of four conditions defining aggregates of  $A$ . These conditions are as follows:

1. *Covering condition.* Let a generic bundle of input-output pairs in  $A(t_0)$  be denoted by  $A_{\alpha_0}(t_0)$ , with  $\alpha_0$  serving as an identifying tag for a bundle. A collection of such bundles will be denoted by  $\{A_{\alpha_0}(t_0)\}$ ,  $\alpha_0 \in \Sigma_{t_0}$ , where  $\Sigma_{t_0}$  is the range of values that can be assumed by  $\alpha_0$  at  $t_0$ ; Anticipating that  $\alpha_0$  will play the role of a state of  $A$ ,  $\Sigma_{t_0}$  will be referred to as the *state space* of  $A$  at time  $t_0$ . Note that  $t_0$  is a variable ranging over the integers  $0, 1, 2, \dots$ .

The covering condition requires that the collection  $\{A_{\alpha_0}(t_0)\}$ ,  $\alpha_0 \in \Sigma_{t_0}$ , be a covering for  $A(t_0)$ ; that is,

$$\bigcup_{\alpha_0} A_{\alpha_0}(t_0) = A(t_0) \quad \text{for all } t_0 \text{ in } \{0, 1, \dots\} \quad (51)$$

In effect, this condition requires that every input-output pair in  $A(t_0)$  be included in some bundle in the collection  $\{A_{\alpha_0}(t_0)\}$ ,  $\alpha_0 \in \Sigma_{t_0}$ .

2. *Uniqueness condition.* The uniqueness condition is expressed by

$$(u, y) \in A_{\alpha_0}(t_0) \text{ and } (u, y') \in A_{\alpha_0}(t_0) \Rightarrow y = y'. \quad (52)$$

In other words, to each input  $u$  in the domain of the relation  $A_{\alpha_0}(t_0)$  corresponds a unique output  $y$ . (Note that the sequences  $u$  and  $y$  are assumed to be of the same length.)

3. *Prefix condition.* Consider an input-output pair  $(uu', yy')$  in  $A_{\alpha_0}(t_0)$ , which is a concatenation of the input-output pairs  $(u, y)$  and  $(u', y')$ . The expression for the condition is

$$(uu', yy') \in A_{\alpha_0}(t_0) \Rightarrow (u, y) \in A_{\alpha_0}(t_0), \quad (53)$$

Thus, this condition requires that any prefix [that is,  $(u, y)$ ] of an input-output pair in  $A_{\alpha_0}(t_0)$  also be an input-output pair in  $A_{\alpha_0}(t_0)$ .

4. *Continuation condition.* As in the preceding condition, let  $(uu', yy')$  be an input-output pair in  $A_{\alpha_0}(t_0)$ , with  $(u', y')$  starting at, say,  $t_1$ . The continuation condition may be expressed as

$$\{(u', y') \mid (uu', yy') \in A_{\alpha_0}(t_0)\} = A_{\alpha_1}(t_1) \quad (54)$$

where  $A_{\alpha_1}(t_1)$  denotes a bundle of input-output pairs starting at  $t_1$ , with the understanding that  $A_{\alpha_1}(t_1)$  is a member of the collection of bundles  $\{A_{\alpha_0}(t_0)\}$ ,  $\alpha_0 \in \Sigma_{t_0}$ ,  $t_0 = 0, 1, 2, \dots$ , and that  $\alpha_1$  ranges over  $\Sigma_{t_1}$ .

Informally, the continuation condition merely asserts that a state  $\alpha_0$  at time  $t_0$  is transferred by input  $u$  into a state  $\alpha_1$  at time  $t_1$ .

In terms of the four conditions stated above, the aggregates and states of a system can be defined as follows:

**Definition**

The *aggregates* of  $A$  are bundles of input-output pairs of  $A$  satisfying the covering, uniqueness, prefix, and continuation conditions. The *states* of  $A$  are names (or tags) of the aggregates of  $A$ . The set of names of the aggregates of input-output pairs starting at  $t_0$  is the *state space* of  $A$  at time  $t_0$ . Usually, the state space  $\Sigma_{t_0}$  is assumed to be independent of  $t_0$ .

With the above definitions as a point of departure, one can deduce all of the properties of the states and state equations of a system that, in the classical approach, are assumed at the outset. The way in which this can be done is described in Ref. [8] and, more explicitly though in lesser detail, in Ref. [9].

In a previous section, we showed how the conventional approach in which the point of departure is the definition of a system through its state equations (14) and (15), can be generalized to fuzzy systems. This naturally gives rise to the question: How can the approach sketched above in which the starting point is (a) the definition of a system as a collection of input-output pairs, (b) the definition of an aggregate as a bundle of input-output pairs satisfying certain conditions, and (c) the definition of a state as a name for an aggregate, be similarly generalized to fuzzy systems?

If we could find an answer to this basic question, we might, perhaps, be able to develop effective techniques for the approximate analysis of complex systems for which state equations cannot be postulated at the outset. We state this question as an open problem because its solution can be perceived only dimly at this rudimentary stage of the development of the theory of fuzzy systems.

## References

- [1] Zadeh, L. A. , "Fuzzy sets," *Information and Control*, vol. 8, pp. 338~353, June 1965.
- [2] Zadeh, L. A. , "Fuzzy sets and systems," *Proc. Symp. System Theory*, Polytech. Inst. ,of Brooklyn pp. 29~39, Apr. 1965.
- [3] Zadeh, L. A. , "Fuzzy algorithms," *Information and contro*, vol. 12, pp. 99~102, Feb. 1968.
- [4] Santos, E. S. , and W. G. Wee, "General formulation of sequential machines," *Information and Control*, vol. 12, pp. 5~10, 1968.
- [5] Santos, E. S. , "Maximin automata," *Information and Control*, vol. 13, pp. 363~377, Oct. 1968.
- [6] Goguen, J. , "L-fuzzy sets," *J. Math. Anal. App.* , vol. 18, pp. 145~174, Apr. 1967.
- [7] Zadeh, L. A. , "Shadows of Fuzzy sets," *Problems in Transmission of Information*(in Russian), vol. 2, pp. 37~44, Mar. 1966.
- [8] Zadeh, L. A. , and C. A. Desoer, *Linear System Theory—The State Space Approach*. New York, McGraw-Hill, 1963.
- [9] Zadeh, L. A. , "The concept of state in system theory," in *Network and Switching Theory*, G. Biorci, ed. New York, Academic Press, 1968.
- [10] Zadeh, L. A. , "The concepts of system, aggregate and state in system theory," in *System Theory*, L. A. Zadeh and E. Polak, eds. New York, McGraw-Hill, 1969.
- [11] Carlyle, J. W. , "Reduced forms for stochastic sequential machines," *J. Math. Anal. Appl.* , vol. 7, pp. 167-175, 1963.

# Outline of a New Approach to the Analysis of Complex Systems and Decision Process

## 1. Introduction

The Advent of the computer age has stimulated a rapid expansion in the use of quantitative techniques for the analysis of economic, urban, social, biological, and other types of systems in which it is the animate rather than inanimate behavior of system constituents that plays a dominant role. At present, most of the techniques employed for the analysis of *humanistic*, i. e. , human-centered, systems are adaptations of the methods that have been developed over a long period of time for dealing with *mechanistic* systems, i. e. , physical systems governed in the main by the laws of mechanics, electromagnetism, and thermodynamics. The remarkable successes of these methods in unraveling the secrets of nature and enabling us to build better and better machines have inspired a widely held belief that the same or similar techniques can be applied with comparable effectiveness to the analysis of humanistic systems. As a case in point, the successes of modern control theory in the design of highly accurate space navigation systems have stimulated its use in the theoretical analyses of economic and biological systems. Similarly, the effectiveness of computer simulation techniques in the macroscopic analyses of physical systems has brought into

vogue the use of computer-based econometric models for purposes of forecasting, economic planning, and management.

Given the deeply entrenched tradition of scientific thinking which equates the understanding of a phenomenon with the ability to analyze it in quantitative terms, one is certain to strike a dissonant note by questioning the growing tendency to analyze the behavior of humanistic systems as if they were mechanistic systems governed by difference, differential, or integral equations. Such a note is struck in the present paper.

Essentially, our contention is that the conventional quantitative techniques of system analysis are intrinsically unsuited for dealing with humanistic systems or, for that matter, any system whose complexity is comparable to that of humanistic systems. The basis for this contention rests on what might be called the *principle of incompatibility*. Stated informally, the essence of this principle is that as the complexity of a system increases, our ability to make precise and yet significant statements about its behavior diminishes until a threshold is reached beyond which precision and significance (or relevance) become almost mutually exclusive characteristics.<sup>①</sup> It is in this sense that precise quantitative analyses of the behavior of humanistic systems are not likely to have much relevance to the real-world societal, political, economic, and other types of problems which involve humans either as individuals or in groups.

---

① A corollary principle may be stated succinctly as, "The closer one looks at a real-world problem, the fuzzier becomes its solution."

An alternative approach outlined in this paper is based on the premise that the key elements in human thinking are not numbers, but labels of fuzzy sets, that is, classes of objects in which the transition from membership to non-membership is gradual rather than abrupt. Indeed, the pervasiveness of fuzziness in human thought processes suggests that much of the logic behind human reasoning is not the traditional two-valued or even multivalued logic, but a logic with fuzzy truths, fuzzy connectives, and fuzzy rules of inference. In our view, it is this fuzzy, and as yet not well-understood, logic that plays a basic role in what may well be one of the most important facets of human thinking, namely, the ability to *summarize* information—to extract from the collections of masses of data impinging upon the human brain those and only those subcollections which are relevant to the performance of the task at hand.

By its nature, a summary is an approximation to what it summarizes. For many purposes, a very approximate characterization of a collection of data is sufficient because most of the basic tasks performed by humans do not require a high degree of precision in their execution. The human brain takes advantage of this tolerance for imprecision by encoding the “task-relevant” (or “decision-relevant”) information into labels of fuzzy sets which bear an approximate relation to the primary data. In this way, the stream of information reaching the brain via the visual, auditory, tactile, and other senses is eventually reduced to the trickle that is needed to perform a specified task with a minimal degree of precision. Thus, the ability to manipulate fuzzy sets and the consequent summarizing capability



constitute one of the most important assets of the human mind as well as a fundamental characteristic that distinguishes human intelligence from the type of machine intelligence that is embodied in present-day digital computers.

Viewed in this perspective, the traditional techniques of system analysis are not well suited for dealing with humanistic systems because they fail to come to grips with the reality of the fuzziness of human thinking and behavior. Thus, to deal with such systems realistically, we need approaches which do not make a fetish of precision, rigor, and mathematical formalism, and which employ instead a methodological framework which is tolerant of imprecision and partial truths. The approach described in the sequel is a step—but not necessarily a definitive step—in this direction.

The approach in question has three main distinguishing features: 1) use of so-called “linguistic” variables in place of or in addition to numerical variables; 2) characterization of simple relations between variables by conditional fuzzy statements; and 3) characterization of complex relations by fuzzy algorithms. Before proceeding to a detailed discussion of our approach, it will be helpful to sketch the principal ideas behind these features. We begin with a brief explanation of the notion of a linguistic variable.

1) *Linguistic and Fuzzy Variables*: As already pointed out, the ability to summarize information plays an essential role in the characterization of complex phenomena. In the case of humans, the ability to summarize information finds its most pronounced manifestation in the use of natural languages. Thus, each word

$x$  in a natural language  $L$  may be viewed as a summarized description of a fuzzy subset  $M(x)$  of a universe of discourse  $U$ , with  $M(x)$  representing the meaning of  $x$ . In this sense, the language as a whole may be regarded as a system for assigning atomic and composite labels (i. e., words, phrases, and sentences) to the fuzzy subsets of  $U$ . (This point of view is discussed in greater detail in [4] and [5].) For example, if the meaning of the noun *flower* is a fuzzy subset  $M(\textit{flower})$ , and the meaning of the adjective *red* is a fuzzy subset  $M(\textit{red})$ , then the meaning of the noun phrase *red flower* is given by the intersection of  $M(\textit{red})$  and  $M(\textit{flower})$ .

If we regard the color of an object as a variable, then its values, *red*, *blue*, *yellow*, *green*, etc., may be interpreted as labels of fuzzy subsets of a universe of objects. In this sense, the attribute *color* is a *fuzzy variable*, that is, a variable whose values are labels of fuzzy sets. It is important to note that the characterization of a value of the variable *color* by a natural label such as *red* is much less precise than the numerical value of the wavelength of a particular color.

In the preceding example, the values of the variable *color* are atomic terms like *red*, *blue*, *yellow*, etc. More generally, the values may be sentences in a specified language, in which case we say that the variable is *linguistic*. To illustrate, the values of the fuzzy variable *height* might be expressible as *tall*, *not tall*, *somewhat tall*, *very tall*, *not very tall*, *very very tall*, *tall but not very tall*, *quite tall*, *more or less tall*. Thus, the values in question are sentences formed from the label *tall*, the negation *not*, the connectives *and* and *but*, and the hedges *very*,

*somewhat, quite, and more or less.* In this sense, the variable *height* as defined above is a linguistic variable.

As will be seen in Section II, the main function of linguistic variables is to provide a systematic means for an approximate characterization of complex or ill-defined phenomena. In essence, by moving away from the use of quantified variables and toward the use of the type of linguistic descriptions employed by humans, we acquire a capability to deal with systems which are much too complex to be susceptible to analysis in conventional mathematical terms.

2) *Characterization of Simple Relations Between Fuzzy Variables by Conditional Statements*; In quantitative approaches to system analysis, a dependence between two numerically valued variables  $x$  and  $y$  is usually characterized by a table which, in words, may be expressed as a set of conditional statements, e. g. , *If  $x$  is 5 Then  $y$  is 10, If  $x$  is 6 Then  $y$  is 14, etc.*

The same technique is employed in our approach, except that  $x$  and  $y$  are allowed to be fuzzy variables. In particular, if  $x$  and  $y$  are linguistic variables, the conditional statements describing the dependence of  $y$  on  $x$  might read (the following italicized words represent the values of fuzzy variables):

*If  $x$  is small Then  $y$  is very large*

*If  $x$  is not very small Then  $y$  is very very large*

*If  $x$  is not small and not large Then  $y$  is not very large*

and so forth.

Fuzzy conditional statements of the form *If  $A$  Then  $B$* , where  $A$  and  $B$  are terms with a fuzzy meaning, e. g. , "If John is

*nice* to you. Then you should be *kind* to him," are used routinely in everyday discourse. However, the meaning of such statements when used in communication between humans is poorly defined. As will be shown in Section V, the conditional statement If *A* Then *B* can be given a precise meaning even when *A* and *B* are fuzzy rather than nonfuzzy sets, provided the meanings of *A* and *B* are defined precisely as specified subsets of the universe of discourse.

In the preceding example, the relation between two fuzzy variables *x* and *y* is *simple* in the sense that it can be characterized as a set of conditional statements of the form If *A* Then *B*, where *A* and *B* are labels of fuzzy sets representing the values of *x* and *y*, respectively. In the case of more complex relations, the characterization of the dependence of *y* on *x* may require the use of a fuzzy algorithm. As indicated below, and discussed in greater detail in Section VI, the notion of a fuzzy algorithm plays a basic role in providing a means of approximate characterization of fuzzy concepts and their interrelations.

3) *Fuzzy-Algorithmic Characterization of Functions and Relations*: The definition of a fuzzy function through the use of fuzzy conditional statements is analogous to the definition of a nonfuzzy function *f* by a table of pairs  $(x, f(x))$ , in which *x* is a generic value of the argument of *f* and *f*(*x*) is the value of the function. Just as a nonfuzzy function can be defined algorithmically e. g. , by a program) rather than by a table, so a fuzzy function can be defined by a fuzzy algorithm rather than as a collection of fuzzy conditional statements. The same applies to the definition of sets, relations, and other constructs which are

fuzzy in nature.

Essentially, a fuzzy algorithm [6] is an ordered sequence of instructions (like a computer program) in which some of the instructions may contain labels of fuzzy sets, e. g. :

Reduce  $x$  *slightly* if  $y$  is *large*

Increase  $x$  *very slightly* if  $y$  is *not very large and not very small*

If  $x$  is *small* then stop; otherwise increase  $x$  by 2.

By allowing an algorithm to contain instructions of this type, it becomes possible to give an approximate fuzzy-algorithmic characterization of a wide variety of complex phenomena. The important feature of such characterizations is that, though imprecise in nature, they may be perfectly adequate for the purposes of a specified task. In this way, fuzzy algorithms can provide an effective means of approximate description of objective functions, constraints, system performance, strategies, etc.

In what follows, we shall elaborate on some of the basic aspects of linguistic variables, fuzzy conditional statements, and fuzzy algorithms. However, we shall not attempt to present a definitive exposition of our approach and its applications. Thus, the present paper should be viewed primarily as an introductory outline of a method which departs from the tradition of precision and rigor in scientific analysis — a method whose approximate nature mirrors the fuzziness of human behavior and thereby offers a promise of providing a more realistic basis for the analysis of humanistic systems.

As will be seen in the following sections, the theoretical

foundation of our approach is actually quite precise and rather mathematical in spirit. Thus, the source of imprecision in the approach is not the underlying theory, but the manner in which linguistic variables and fuzzy algorithms are applied to the formulation and solution of real-world problems. In effect, the level of precision in a particular application can be adjusted to fit the needs of the task and the accuracy of the available data. This flexibility constitutes one of the important features of the method that will be described.

## 2. Fuzzy Sets: A summary of relevant properties

In order to make our exposition self-contained, we shall summarize in this section those properties of fuzzy sets which will be needed in later sections. (More detailed discussions of topics in the theory of fuzzy sets which are relevant to the subject of the present paper may be found in [1]~[17].)

### *Notation and Terminology*

A fuzzy subset  $A$  of a universe of discourse  $U$  is characterized by a membership function  $\mu_A : U \rightarrow [0, 1]$  which associates with each element  $y$  of  $U$  a number  $\mu_A(y)$  in the interval  $[0, 1]$  which represents the grade of membership of  $y$  in  $A$ . The *support* of  $A$  is the set of points in  $U$  at which  $\mu_A(y)$  is positive. A *crossover point* in  $A$  is an element of  $U$  whose grade of membership in  $A$  is 0.5. A *fuzzy singleton* is a fuzzy set whose support is a single point in  $U$ . If  $A$  is a fuzzy singleton whose support is the point  $y$ , we write

$$A = \mu/y \quad (2.1)$$

where  $\mu$  is the grade of membership of  $y$  in  $A$ . To be consistent

with this notation, a nonfuzzy singleton will be denoted by  $1/y$ .

A fuzzy set  $A$  may be viewed as the union (see (2.27)) of its constituent singletons. On this basis,  $A$  may be represented in the form

$$A = \int_U \mu_A(y)/y \quad (2.2)$$

where the integral sign stands for the union of the fuzzy singletons  $\mu_A(y)/y$ . If  $A$  has a finite support  $\{y_1, y_2, \dots, y_n\}$ , then (2.2) may be replaced by the summation

$$A = \mu_1/y_1 + \dots + \mu_n/y_n \quad (2.3)$$

or

$$A = \sum_{i=1}^n \mu_i/y_i \quad (2.4)$$

in which  $\mu_i, i=1, \dots, n$ , is the grade of membership of  $y_i$  in  $A$ . It should be noted that the  $+$  sign in (2.3) denotes the union (see (2.27)) rather than the arithmetic sum. In this sense of  $+$ , a finite universe of discourse  $U = \{y_1, y_2, \dots, y_n\}$  may be represented simply by the summation

$$U = y_1 + y_2 + \dots + y_n \quad (2.5)$$

or

$$U = \sum_{i=1}^n y_i \quad (2.6)$$

although, strictly, we should write (2.5) and (2.6) as

$$U = 1/y_1 + 1/y_2 + \dots + 1/y_n \quad (2.7)$$

and

$$U = \sum_{i=1}^n 1/y_i \quad (2.8)$$

As an illustration, suppose that

$$U = 1 + 2 + \dots + 10. \quad (2.9)$$

Then a fuzzy subset<sup>①</sup> of  $U$  labeled *several* may be expressed as (the symbol  $\triangleq$  stands for "equal by definition," or "is defined to be," or "denotes")

$$\textit{several} \triangleq 0.5/3 + 0.8/4 + 1/5 + 1/6 + 0.8/7 + 0.5/8. \quad (2.10)$$

Similarly, if  $U$  is the interval  $[0, 100]$ , with  $y \triangleq$  age, then the fuzzy subsets of  $U$  labeled *young* and *old* may be represented as (here and elsewhere in this paper we do not differentiate between a fuzzy set and its label)

$$\textit{young} = \int_0^{25} 1/y + \int_{25}^{100} \left( 1 + \left( \frac{y-25}{5} \right)^2 \right)^{-1} / y \quad (2.11)$$

$$\textit{old} = \int_{50}^{100} \left( 1 + \left( \frac{y-50}{5} \right)^2 \right)^{-1} / y. \quad (2.12)$$

(see Fig. 1).

The grade of membership in a fuzzy set may itself be a fuzzy set. For example, if

$$U = \text{TOM} + \text{JIM} + \text{DICK} + \text{BOB} \quad (2.13)$$

and  $A$  is the fuzzy subset labeled *agile*, then we may have

$$\begin{aligned} \textit{agile} = \textit{medium}/\text{TOM} + \textit{low}/\text{JIM} + \textit{low}/\text{DICK} \\ + \textit{high}/\text{BOB}. \end{aligned} \quad (2.14)$$

In this representation, the fuzzy grades of membership *low*, *medium*, and *high* are fuzzy subsets of the universe  $V$

$$V = 0 + 0.1 + 0.2 + \dots + 0.9 + 1 \quad (2.15)$$

which are defined by

---

①  $A$  is a subset of  $B$ , written  $A \subset B$ , if and only if  $\mu_A(y) \leq \mu_B(y)$ , for all  $y$  in  $U$ . For example, the fuzzy set  $A = 0.6/1 + 0.3/2$  is a subset of  $B = 0.8/1 + 0.5/2 + 0.6/3$ .



$$low = 0.5/0.2 + 0.7/0.3 + 1/0.4 + 0.7/0.5 + 0.5/0.6 \quad (2.16)$$

$$medium = 0.5/0.4 + 0.7/0.5 + 1/0.6 + 0.7/0.7 + 0.5/0.8 \quad (2.17)$$

$$high = 0.5/0.7 + 0.7/0.8 + 0.9/0.9 + 1/1. \quad (2.18)$$

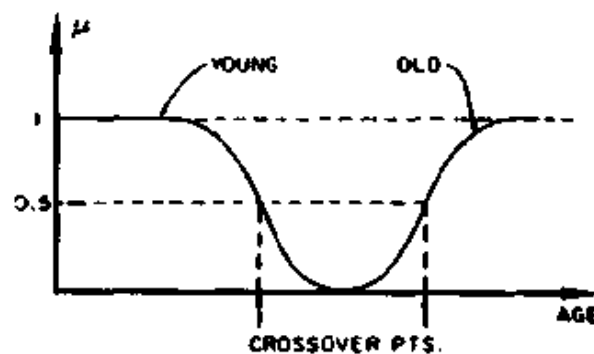

Fig. 1. Diagrammatic representation of *young* and *old*.

### Fuzzy Relations

A *fuzzy relation*  $R$  from a set  $X$  to a set  $Y$  is a fuzzy subset of the Cartesian product  $X \times Y$ . ( $X \times Y$  is the collection of ordered pairs  $(x, y)$ ,  $x \in X$ ,  $y \in Y$ ).  $R$  is characterized by a bivariate membership function  $\mu_R(x, y)$  and is expressed

$$R \triangleq \int_{X \times Y} \mu_R(x, y) / (x, y). \quad (2.19)$$

More generally, for an  $n$ -ary fuzzy relation  $R$  which is a fuzzy subset of  $X_1 \times X_2 \times \dots \times X_n$  we have

$$R \triangleq \int_{X_1 \times \dots \times X_n} \mu_R(x_1, \dots, x_n) / (x_1, \dots, x_n),$$

$$x_i \in X_i, i = 1, \dots, n. \quad (2.20)$$

As an illustration, if

$$X = \{TOM, DICK\} \text{ and } Y = \{JOHN, JIM\}$$

then a binary fuzzy relation of *resemblance* between members of  $X$  and  $Y$  might be expressed as

$resemblance = 0.8/(TOM, JOHN) + 0.6/(TOM, JIM) + 0.2/(DICK, JOHN) + 0.9/(DICK, JIM).$

Alternatively, this relation may be represented as a *relation matrix*

$$\begin{array}{cc} & \begin{array}{cc} JOHN & JIM \end{array} \\ \begin{array}{c} TOM \\ DICK \end{array} & \begin{bmatrix} 0.8 & 0.6 \\ 0.2 & 0.9 \end{bmatrix} \end{array} \quad (2.21)$$

in which the  $(i, j)$ th element is the value of  $\mu_R(x, y)$  for the  $i$ th value of  $x$  and the  $j$ th value of  $y$ .

If  $R$  is a relation from  $X$  to  $Y$  and  $S$  is a relation from  $Y$  to  $Z$ , then the *composition* of  $R$  and  $S$  is a fuzzy relation denoted by  $R \circ S$  and defined by

$$R \circ S \triangleq \int_{X \times Z} \bigvee_y (\mu_R(x, y) \wedge \mu_S(y, z)) / (x, z) \quad (2.22)$$

where  $\bigvee$  and  $\wedge$  denote, respectively, max and min.<sup>①</sup> Thus, for real  $a, b$ ,

$$a \vee b = \max(a, b) \triangleq \begin{cases} a, & \text{if } a \geq b \\ b, & \text{if } a < b \end{cases} \quad (2.23)$$

$$a \wedge b = \min(a, b) \triangleq \begin{cases} a, & \text{if } a \leq b \\ b, & \text{if } a > b \end{cases} \quad (2.24)$$

and  $\bigvee_y$  is the supremum over the domain of  $y$ .

If the domains of the variables  $x, y$ , and  $z$  are finite sets, then the relation matrix for  $R \circ S$  is the max-min product<sup>②</sup> of the

① Equation(2.22) defines the max-min composition of  $R$  and  $S$ . Max-product composition is defined similarly, except that  $\wedge$  is replaced by the arithmetic product. A more detailed discussion of these compositions may be found in [2].

② In the max-min matrix product, the operations of addition and multiplication are replaced by  $\bigvee$  and  $\wedge$ , respectively.

relation matrices for  $R$  and  $S$ . For example, the max-min product of the relation matrices on the left-hand side of (2.25) results in the relation matrix  $R \circ S$  shown on the right-hand side of

$$\begin{array}{ccc} R & S & R \circ S \\ \begin{bmatrix} 0.3 & 0.8 \\ 0.6 & 0.9 \end{bmatrix} \circ \begin{bmatrix} 0.5 & 0.9 \\ 0.4 & 1 \end{bmatrix} & = & \begin{bmatrix} 0.4 & 0.8 \\ 0.5 & 0.9 \end{bmatrix}. \end{array} \quad (2.25)$$

### Operations on Fuzzy Sets

The negation *not*, the connectives *and* and *or*, the hedges *very*, *highly*, *more or less*, and other terms which enter in the representation of values of linguistic variables may be viewed as labels of various operations defined on the fuzzy subsets of  $U$ . The more basic of these operations will be summarized.

The *complement* of  $A$  is denoted  $\neg A$  and is defined by

$$\neg A \triangleq \int_U (1 - \mu_A(y)) / y. \quad (2.26)$$

The operation of complementation corresponds to negation. Thus, if  $x$  is a label for a fuzzy set, then *not*  $x$  should be interpreted as  $\neg x$ . (Strictly speaking,  $\neg$  operates on fuzzy sets, whereas *not* operates on their labels. With this understanding, we shall use  $\neg$  and *not* interchangeably.)

The *union* of fuzzy sets  $A$  and  $B$  is denoted  $A + B$  and is defined by

$$A + B \triangleq \int_U (\mu_A(y) \vee \mu_B(y)) / y. \quad (2.27)$$

The union corresponds to the connective *or*. Thus, if  $u$  and  $v$  are labels of fuzzy sets, then

$$u \text{ or } v \triangleq u + v \quad (2.28)$$

The *intersection* of  $A$  and  $B$  is denoted  $A \cap B$  and is defined by

$$A \cap B \triangleq \int_U (\mu_A(y) \wedge \mu_B(y)) / y. \quad (2.29)$$

The intersection corresponds to the connective *and*; thus

$$u \text{ and } v \triangleq u \cap v. \quad (2.30)$$

As an illustration, if

$$U = 1 + 2 + \dots + 10 \quad (2.31)$$

$$u = 0.8/3 + 1/5 + 0.6/6 \quad (2.32)$$

$$v = 0.7/3 + 1/4 + 0.5/6 \quad (2.33)$$

then

$$u \text{ or } v = 0.8/3 + 1/4 + 1/5 + 0.6/6 \quad (2.34)$$

$$u \text{ and } v = 0.7/3 + 0.5/6. \quad (2.35)$$

The *product* of  $A$  and  $B$  is denoted  $AB$  and is defined by

$$AB \triangleq \int_U \mu_A(y) \mu_B(y) / y. \quad (2.36)$$

Thus, if

$$A = 0.8/2 + 0.9/5 \quad (2.37)$$

$$B = 0.6/2 + 0.8/3 + 0.6/5 \quad (2.38)$$

then

$$AB = 0.48/2 + 0.54/5. \quad (2.39)$$

Based on (2.36),  $A^\alpha$ , where  $\alpha$  is any positive number, is defined by

$$A^\alpha \triangleq \int_U (\mu_A(y))^\alpha / y. \quad (2.40)$$

Similarly, if  $\alpha$  is a nonnegative real number, then

$$\alpha A \triangleq \int_U \alpha \mu_A(y) / y. \quad (2.41)$$

As an illustration, if  $A$  is expressed by (2.27), then

$$A^2 = 0.64/2 + 0.81/5 \quad (2.42)$$

$$0.5A = 0.4/2 + 0.45/5. \quad (2.43)$$

In addition to the basic operations just defined, there are other operations that are of use in the representation of linguistic hedges. Some of these will be briefly defined. (A more detailed discussion of these operations may be found in [15].)

The operation of *concentration* is defined by

$$\text{CON}(A) \triangleq A^2. \quad (2.44)$$

Applying this operation to  $A$  results in a fuzzy subset of  $A$  such that the reduction in the magnitude of the grade of membership of  $y$  in  $A$  is relatively small for those  $y$  which have a high grade of membership in  $A$  and relatively large for the  $y$  with low membership.

The operation of *dilation* is defined by

$$\text{DIL}(A) \triangleq A^{0.5}. \quad (2.45)$$

The effect of this operation is the opposite of that of concentration.

The operation of *contrast intensification* is defined by

$$\text{INT}(A) \triangleq \begin{cases} 2A^2, & \text{for } 0 \leq \mu_A(y) \leq 0.5 \\ \neg 2(\neg A)^2, & \text{for } 0.5 \leq \mu_A(y) \leq 1. \end{cases} \quad (2.46)$$

This operation differs from concentration in that it increases the values of  $\mu_A(y)$  which are above 0.5 and diminishes those which are below this point. Thus, contrast intensification has the effect of reducing the fuzziness of  $A$ . (An entropy-like measure of fuzziness of a fuzzy set is defined in [16].)

As its name implies, the operation of *fuzzification* (or, more specifically, *support fuzzification*) has the effect of

transforming a nonfuzzy set into a fuzzy set or increasing the fuzziness of a fuzzy set. The result of application of a fuzzification to  $A$  will be denoted by  $F(A)$  or  $\tilde{A}$ , with the wavy overbar referred to as a *fuzzifier*. Thus  $x \approx 3$  means “ $x$  is approximately equal to 3,” while  $x = \tilde{3}$  means “ $x$  is a fuzzy set which approximates to 3.” A fuzzifier  $F$  is characterized by its *kernel*  $K(y)$ , which is the fuzzy set resulting from the application of  $F$  to a singleton  $1/y$ . Thus

$$K(y) \triangleq \tilde{1/y} \quad (2.47)$$

In terms of  $K$ , the result of applying  $F$  to a fuzzy set  $A$  is given by

$$F(A;K) \triangleq \int_U \mu_A(y)K(y) \quad (2.48)$$

where  $\mu_A(y)K(y)$  represents the product (in the sense of (2.41)) of the scalar  $\mu_A(y)$  and the fuzzy set  $K(y)$ , and  $\int_U$  should be interpreted as the union of the family of fuzzy sets  $\mu_A(y)K(y)$ ,  $y \in U$ . Thus (2.48) is analogous to the integral representation of a linear operator, with  $K(y)$  playing the role of impulse response.

As an illustration of (2.48), assume that  $U, A$ , and  $K(y)$  are defined by

$$U = 1 + 2 + 3 + 4 \quad (2.49)$$

$$A = 0.8/1 + 0.6/2 \quad (2.50)$$

$$K(1) = 1/1 + 0.4/2 \quad (2.51)$$

$$K(2) = 1/2 + 0.4/1 + 0.4/3.$$

Then, the result of applying  $F$  to  $A$  is given by

$$F(A;K) = 0.8(1/1 + 0.4/2) + 0.6(1/2 + 0.4/1 + 0.4/3)$$

$$\begin{aligned}
&=0.8/1+0.32/2+0.6/2+0.24/1+0.24/3 \\
&=0.8/1+0.6/2+0.24/3 \qquad (2.52)
\end{aligned}$$

The operation of fuzzification plays an important role in the definition of linguistic hedges such as *more or less*, *slightly*, *much*, etc. Examples of its uses are given in [15].

### *Language and Meaning*

As was indicated in Section 1, the values of a linguistic variable are fuzzy sets whose labels are sentences in a natural or artificial language. For our purposes, a language  $L$  may be viewed as a correspondence between a set of terms  $T$  and a universe of discourse  $U$ . (This point of view is described in greater detail in [4] and [5]. For simplicity, we assume that  $T$  is a nonfuzzy set.) This correspondence may be assumed to be characterized by a fuzzy naming relation  $N$  from  $T$  to  $U$ , which associates with each term  $x$  in  $T$  and each object  $y$  in  $U$  the degree  $\mu_N(x, y)$  to which  $x$  applies to  $y$ . For example, if  $x = \textit{young}$  and  $y = 23$  years, then  $\mu_N(\textit{young}, 23)$  might be 0.9. A term may be atomic, e. g.,  $x = \textit{tall}$ , or composite, in which case it is a concatenation of atomic terms, e. g.,  $x = \textit{very tall man}$ .

For a fixed  $x$ , the membership function  $\mu_N(x, y)$  defines a fuzzy subset  $M(x)$  of  $U$  whose membership function is given by

$$\mu_{M(x)}(y) \triangleq \mu_N(x, y), x \in T, y \in U. \qquad (2.53)$$

This fuzzy subset is defined to be the *meaning of  $x$* . Thus, the meaning of a term  $x$  is the fuzzy subset  $M(x)$  of  $U$  for which  $x$  serves as a label. Although  $x$  and  $M(x)$  are different entities ( $x$  is an element of  $T$ , whereas  $M(x)$  is a fuzzy subset of  $U$ ), we shall write  $x$  for  $M(x)$ , except where there is a need for differentiation between them. To illustrate, suppose that the meaning of the

term *young* is defined by

$$\mu_N(\text{young}, y) = \begin{cases} 1, & \text{for } y \leq 25 \\ \left(1 + \left(\frac{y-25}{5}\right)^2\right)^{-1}, & \text{for } y > 25. \end{cases} \quad (2.54)$$

Then we can represent the fuzzy subset of  $U$  labeled *young* as (see (2.11))

$$\text{young} = \int_0^{25} 1/y + \int_{25}^{100} \left(1 + \left(\frac{y-25}{5}\right)^2\right)^{-1} / y \quad (2.55)$$

with the right-hand member of (2.55) representing the meaning of *young*.

Linguistic hedges such as *very*, *much*, *more or less*, etc., make it possible to modify the meaning of atomic as well as composite terms and thus serve to increase the range of values of a linguistic variable. The use of linguistic hedges for this purpose is discussed in the following section.

### 3. Linguistic hedges

As stated in Section I, the values of a linguistic variable are labels of fuzzy subsets of  $U$  which have the form of phrases or sentences in a natural or artificial language. For example, if  $U$  is the collection of integers

$$U = 0 + 1 + 2 + \dots + 100 \quad (3.1)$$

and *age* is a linguistic variable labeled  $x$ , then the values of  $x$  might be *young*, *not young*, *very young*, *not very young*, *old* and *not old*, *not very old*, *not young and not old*, etc.

In general, a value of a linguistic variable is a composite term  $x = x_1 x_2 \dots x_n$ , which is a concatenation of atomic terms  $x_1, \dots, x_n$ . These atomic terms may be divided into four categories:



1) *primary terms*, which are labels of specified fuzzy subsets of the universe of discourse (e. g. ,*young* and *old* in the preceding example);

2) the negation *not* and the connectives *and* and *or*;

3) *hedges*, such as *very*, *much*, *slightly*, *more or less* (although *more or less* is comprised of three words, it is regarded as an atomic term), etc. ;

4) *markers*, such as parentheses.

A basic problem  $P_i$  which arises in connection with the use of linguistic variables is the following: Given the meaning of each atomic term  $x_i, i = 1, \dots, n$ , in a composite term  $x = x_1 \dots x_n$  which represents a value of a linguistic variable, compute the meaning of  $x$  in the sense of (2.53). This problem is an instance of a central problem in quantitative fuzzy semantics [4], namely, the computation of the meaning of a composite term.  $P_i$  is a special case of the latter problem because the composite terms representing the values of a linguistic variable have a relatively simple grammatical structure which is restricted to the four categories of atomic terms 1) ~ 4).

As a preliminary to describing a general approach to the solution of  $P_i$ , it will be helpful to consider a subproblem of  $P_i$  which involves the computation of the meaning of a composite term of the form  $x = hu$ , where  $h$  is a hedge and  $u$  is a term with a specified meaning; e. g. ,  $x = \textit{very tall man}$ , where  $h = \textit{very}$  and  $u = \textit{tall man}$ .

Taking the point of view described in [15], a hedge  $h$  may be regarded as an operator which transforms the fuzzy set  $M(u)$ , representing the meaning of  $u$ , into the fuzzy set  $M(hu)$ . As

stated already, the hedges serve the function of generating a larger set of values for a linguistic variable from a small collection of primary terms. For example, by using the hedge *very* in conjunction with *not*, *and*, and the primary term *tall*, we can generate the fuzzy sets *very tall*, *very very tall*, *not very tall*, *tall and not very tall*, etc. To define a hedge  $h$  as an operator, it is convenient to employ some of the basic operations defined in Section I, especially concentration, dilation, and fuzzification. In what follows, we shall indicate the manner in which this can be done for the natural hedge *very* and the artificial hedges *plus* and *minus*. Characterizations of such hedges as *more or less*, *much*, *slightly*, *sort of*, and *essentially* may be found in [15].

Although in its everyday use the hedge *very* does not have a well-defined meaning, in essence it acts as an intensifier, generating a subset of the set on which it operates. A simple operation which has this property is that of concentration (see (2.44)). This suggests that *very x*, where  $x$  is a term, be defined as the square of  $x$ , that is

$$\text{very } x \triangleq x^2 \quad (3.2)$$

or, more explicitly

$$\text{very } x \triangleq \int_U \mu_x^2(y)/y. \quad (3.3)$$

For example, if (see Fig. 2)

$$x = \text{old men} \triangleq \int_{50}^{100} \left( 1 + \left( \frac{y-50}{5} \right)^{-2} \right)^{-1} / y \quad (3.4)$$

then

$$x^2 = \text{very old men} = \int_{50}^{100} \left( 1 + \left( \frac{y-50}{5} \right)^{-2} \right)^{-2} / y. \quad (3.5)$$

Thus, if the grade of membership of JOHN in the class of *old men* is 0.8, then his grade of membership in the class of *very old men* is 0.64. As another simple example, if

$$U = 1 + 2 + 3 + 4 + 5 \quad (3.6)$$

and

$$small = 1/1 + 0.8/2 + 0.6/3 + 0.4/4 + 0.2/5 \quad (3.7)$$

then

$$very\ small = 1/1 + 0.64/2 + 0.36/3 + 0.16/4 + 0.04/5. \quad (3.8)$$

Viewed as an operator, *very* can be composed with itself. Thus

$$very\ very\ x = (very\ x)^2 = x^4. \quad (3.9)$$

For example, applying (3.9) to (3.7), we obtain (neglecting small terms)

$$very\ very\ small = 1/1 + 0.4/2 + 0.1/3. \quad (3.10)$$

In some instances, to identify the operand of *very* we have to use parentheses or replace a composite term by an atomic one. For example, it is not grammatical to write

$$x = very\ not\ exact \quad (3.11)$$

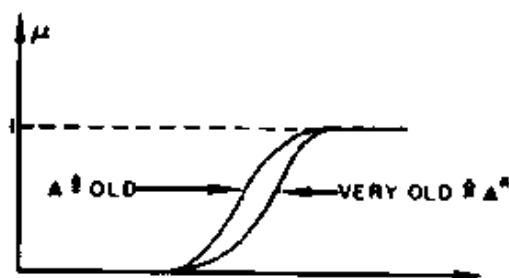

Fig. 2. Effect of hedge *very*.

but if *not exact* is replaced by the atomic term *inexact*, then

$$x = \text{very inexact} \quad (3.12)$$

is grammatically correct and we can write

$$x = (\neg \text{exact})^2. \quad (3.13)$$

Note that

$$\text{not very exact} = \neg(\text{very exact}) = \neg(\text{exact}^2) \quad (3.14)$$

is not the same as (3.13).

The artificial hedges *plus* and *minus* serve the purpose of providing milder degrees of concentration and dilation than those associated with the operations CON and DIL (see (2.44), (2.45)). Thus, as operators acting on a fuzzy set labeled  $x$ , *plus* and *minus* are defined by

$$\text{plus } x \triangleq x^{1.25} \quad (3.15)$$

$$\text{minus } x \triangleq x^{0.75} \quad (3.16)$$

In consequence of (3.15) and (3.16), we have the approximate identity

$$\text{plus plus } x = \text{minus very } x. \quad (3.17)$$

As an illustration, if the hedge *highly* is defined as

$$\text{highly} = \text{minus very very} \quad (3.18)$$

then, equivalently,

$$\text{highly} = \text{plus plus very}. \quad (3.19)$$

As was stated earlier, the computation of the meaning of composite terms of the form  $hu$  is a preliminary to the problem of computing the meaning of values of a linguistic variable. We are now in a position to turn our attention to this problem.

#### 4. Computation of the meaning of values of a linguistic variable

Once we know how to compute the meaning of a composite

term of the form  $hu$ , the computation of the meaning of a more complex composite term, which may involve the terms *not*, *or*, and *and* in addition to terms of the form  $hu$ , becomes a relatively simple problem which is quite similar to that of the computation of the value of a Boolean expression. As a simple illustration, consider the computation of the meaning of the composite term

$$x = \textit{not very small} \quad (4.1)$$

where the primary term *small* is defined as

$$\textit{small} = 1/1 + 0.8/2 + 0.6/3 + 0.4/4 + 0.2/5 \quad (4.2)$$

with the universe of discourse being

$$U = 1 + 2 + 3 + 4 + 5. \quad (4.3)$$

By (3.8), the operation of *very* on *small* yields

$$\begin{aligned} \textit{very small} &= 1/1 + 0.64/2 + 0.36/3 + 0.16/4 + 0.04/5 \\ &\quad (4.4) \end{aligned}$$

and by (2.26),

$$\begin{aligned} \textit{not very small} &= \neg(\textit{very small}) \\ &= 0.36/2 + 0.64/3 + 0.84/4 + 0.96/5 \\ &\approx 0.4/2 + 0.6/3 + 0.8/4 + 1/5. \quad (4.5) \end{aligned}$$

As a slightly more complicated example, consider the composite term

$$x = \textit{not very small and not very very large} \quad (4.6)$$

where *large* is defined by

$$\textit{large} = 0.2/1 + 0.4/2 + 0.6/3 + 0.8/4 + 1/5. \quad (4.7)$$

In this case,

$$\begin{aligned} \textit{very large} &= (\textit{large})^2 \\ &= 0.04/1 + 0.16/2 + 0.36/3 + 0.64/4 + 1/5 \\ &\quad (4.8) \end{aligned}$$

$$\textit{very very large} = ((\textit{large})^2)^2$$

$$\approx 0.1/3 + 0.4/4 + 1/5 \quad (4.9)$$

$$\text{not very very large} \approx 1/1 + 1/2 + 0.9/3 + 0.6/4 \quad (4.10)$$

and hence

*not very small and not very very large*

$$\begin{aligned} &\approx (0.4/2 + 0.6/3 + 0.8/4 + 1/5) \\ &\quad \cap (1/1 + 1/2 + 0.9/3 + 0.6/4) \\ &\approx (0.4/2 + 0.6/3 + 0.6/4). \end{aligned} \quad (4.11)$$

An example of a different nature is provided by the values of a linguistic variable labeled *likelihood*. In this case, we assume that the universe of discourse is given by

$$U = 0 + 0.1 + 0.2 + 0.3 + 0.4 + 0.5 + 0.6 + 0.7 + 0.8 + 0.9 + 1 \quad (4.12)$$

in which the elements of  $U$  represent probabilities. Suppose that we wish to compute the meaning of the value

$$x = \text{highly unlikely} \quad (4.13)$$

in which *highly* is defined as (see (3.18))

$$\text{highly} = \text{minus very very} \quad (4.14)$$

and

$$\text{unlikely} = \text{not likely} \quad (4.15)$$

with the meaning of the primary term *likely* given by

$$\begin{aligned} \text{likely} = &1/1 + 1/0.9 + 1/0.8 + 0.8/0.7 \\ &+ 0.6/0.6 + 0.5/0.5 + 0.3/0.4 + 0.2/0.3. \end{aligned} \quad (4.16)$$

Using (4.15), we obtain

$$\begin{aligned} \text{unlikely} = &1/0 + 1/0.1 + 1/0.2 + 0.8/0.3 + 0.7/0.4 \\ &+ 0.5/0.5 + 0.4/0.6 + 0.2/0.7 \end{aligned} \quad (4.17)$$

and hence

$$\text{very very unlikely}$$

$$\begin{aligned}
&= (\textit{unlikely})^4 \\
&\approx 1/0 + 1/0.1 + 1/0.2 + 0.4/0.3 + 0.2/0.4. \quad (4.18)
\end{aligned}$$

Finally, by (4.14)

*highly unlikely*

$$\begin{aligned}
&= \textit{minus very very unlikely} \\
&\approx (1/0 + 1/0.1 + 1/0.2 + 0.4/0.3 + 0.2/0.4)^{0.75} \\
&\approx 1/0 + 1/0.1 + 1/0.2 + 0.5/0.3 + 0.3/0.4. \quad (4.19)
\end{aligned}$$

It should be noted that in computing the meaning of composite terms in the preceding examples we have made implicit use of the usual precedence rules governing the evaluation of Boolean expressions. With the addition of hedges, these precedence rules may be expressed as follows.

Precedence	Operation
First	<i>h, not</i>
Second	<i>and</i>
Third	<i>or</i>

As usual, parentheses may be used to change the precedence order and ambiguities may be resolved by the use of association to the right. Thus *plus very minus very tall* should be interpreted as

$$\textit{plus}(\textit{very}(\textit{minus}(\textit{very}(\textit{tall}))))).$$

The technique that was employed for the computation of the meaning of a composite term is a special case of a more general approach which is described in [4] and [5]. The approach in question can be applied to the computation of the meaning of values of a linguistic variable provided the composite terms representing these values can be generated by a context-free

grammar. As an illustration, consider a linguistic variable  $x$  whose values are exemplified by *small, not small, large, not large, very small, not very small, small or not very very large, small and (large or not small), not very very small and not very very large, etc.*

The values in question can be generated by a context-free grammar  $G = (V_T, V_N, S, P)$  in which the set of terminals  $V_T$  comprises the atomic terms *small, large, not, and, or, very, etc*; the nonterminals are denoted  $S, A, B, C, D,$  and  $E$ ; and the production system is given by

$$\begin{array}{ll}
 S \rightarrow A & C \rightarrow D \\
 S \rightarrow S \text{ or } A & C \rightarrow E \\
 A \rightarrow B & D \rightarrow \text{very}D \\
 A \rightarrow A \text{ and } B & E \rightarrow \text{very}E \\
 B \rightarrow C & D \rightarrow \text{small} \\
 B \rightarrow \text{not}C & E \rightarrow \text{large} \\
 C \rightarrow (S) & \qquad \qquad \qquad (4.20)
 \end{array}$$

Each production in (4.20) gives rise to a relation between the fuzzy sets labeled by the corresponding terminal and nonterminal symbols. In the case (4.20), these relations are (we omit the productions which have no effect on the associated fuzzy sets)

$$\begin{array}{l}
 S \rightarrow S \text{ or } A \Rightarrow S_L = S_R + A_R \\
 A \rightarrow A \text{ and } B \Rightarrow A_L = A_R \cap B_R \\
 B \rightarrow \text{not } C \Rightarrow B_L = \neg C_R \\
 D \rightarrow \text{very } D \Rightarrow D_L = D_R^2 \\
 E \rightarrow \text{very } E \Rightarrow E_L = E_R^2 \\
 D \rightarrow \text{small} \Rightarrow D_L = \text{small}
 \end{array}$$



$$E \rightarrow large \Rightarrow E_L = large \quad (4.21)$$

in which the subscripts  $L$  and  $R$  are used to differentiate between the symbols on the left-and right-hand sides of a production.

To compute the meaning of a composite term  $x$ , it is necessary to perform a syntactical analysis of  $x$  in terms of the specified grammar  $G$ . Then, knowing the syntax tree of  $x$ , one can employ the relations given in (4.21) to derive a set of equations (in triangular form) which upon solution yield the meaning of  $x$ . For example, in the case of the composite term

$$x = \textit{not very small and not very very large}$$

the solution of these equations yields

$$x = (\neg \textit{small}^2) \cap (\neg \textit{large}^4) \quad (4.22)$$

which agrees with (4.11). Details of this solution may be found in [4] and [5].

The ability to compute the meaning of values of a linguistic variable is a prerequisite to the computation of the meaning of fuzzy conditional statements of the form IF  $A$  THEN  $B$ , e. g., IF  $x$  is *not very small* THEN  $y$  is *very very large*. This problem is considered in the following section.

### 5. Fuzzy conditional statements and compositional rule of inference

In classical propositional calculus,<sup>①</sup> the expression IF  $A$  THEN  $B$ , where  $A$  and  $B$  are propositional variables, is written as  $A \Rightarrow B$ , with the implication  $\Rightarrow$  regarded as a connective which

---

① A detailed discussion of the significance of implication and its role in modal logic may be found in [18].

is defined by the truth table.

$A$	$B$	$A \Rightarrow B$
$T$	$T$	$T$
$T$	$F$	$F$
$F$	$T$	$T$
$F$	$F$	$T$

Thus,

$$A \Rightarrow B \equiv \neg A \vee B \quad (5.1)$$

in the sense that the propositional expressions  $A \Rightarrow B$  ( $A$  implies  $B$ ) and  $\neg A \vee B$  (not  $A$  or  $B$ ) have identical truth tables.

A more general concept, which plays an important role in our approach, is a *fuzzy conditional statement*: IF  $A$  THEN  $B$  or, for short,  $A \Rightarrow B$ , in which  $A$  (the antecedent) and  $B$  (the consequent) are fuzzy sets rather than propositional variables. The following are typical examples of such statements:

IF *large* THEN *small*

IF *slippery* THEN *dangerous*

which are abbreviations of the statements

IF  $x$  is *large* THEN  $y$  is *small*

IF the road is *slippery* THEN driving is *dangerous*.

In essence, statements of this form describe a relation between two fuzzy variables. This suggests that a fuzzy conditional statement be defined as a fuzzy relation in the sense of (2.19) rather than as a connective in the sense of (5.1).

To this end, it is expedient to define first the *Cartesian product* of two fuzzy sets. Specifically, let  $A$  be a fuzzy subset of a universe of discourse  $U$ , and let  $B$  be a fuzzy subset of a possibly different universe of discourse  $V$ . Then, the Cartesian

product of  $A$  and  $B$  is denoted by  $A \times B$  and is defined by

$$A \times B \triangleq \int_{U \times V} \mu_A(u) \wedge \mu_B(v) / (u, v), \quad (5.2)$$

where  $U \times V$  denotes the Cartesian product of the nonfuzzy sets  $U$  and  $V$ ; that is,

$$U \times V \triangleq \{(u, v) | u \in U, v \in V\}.$$

Note that when  $A$  and  $B$  are nonfuzzy, (5.2) reduces to the conventional definition of the Cartesian product of nonfuzzy sets. In words, (5.2) means that  $A \times B$  is a fuzzy set of ordered pairs  $(u, v)$ ,  $u \in U, v \in V$ , with the grade of membership of  $(u, v)$  in  $A \times B$  given by  $\mu_A(u) \wedge \mu_B(v)$ . In this sense,  $A \times B$  is a fuzzy relation from  $U$  to  $V$ .

As a very simple example, suppose that

$$U = 1 + 2, \quad (5.3)$$

$$V = 1 + 2 + 3, \quad (5.4)$$

$$B = 0.6/1 + 0.9/2 + 1/3. \quad (5.6)$$

Then

$$\begin{aligned} A \times B = & 0.6/(1, 1) + 0.9/(1, 2) + 1/(1, 3) + 0.6/(2, 1) \\ & + 0.8/(2, 2) + 0.8/(2, 3). \end{aligned} \quad (5.7)$$

The relation defined by (5.7) may be conveniently represented by the relation matrix

$$\begin{array}{cc} & \begin{array}{ccc} 1 & 2 & 3 \end{array} \\ \begin{array}{c} 1 \\ 2 \end{array} & \left[ \begin{array}{ccc} 0.6 & 0.9 & 1 \\ 0.6 & 0.8 & 0.8 \end{array} \right]. \end{array} \quad (5.8)$$

The significance of a fuzzy conditional statement of the form IF  $A$  THEN  $B$  is made clearer by regarding it as a special case of the conditional expression IF  $A$  THEN  $B$  ELSE  $C$ , where  $A$  and ( $B$  and  $C$ ) are fuzzy subsets of possibly different universes  $U$  and

$V$ , respectively. In terms of the Cartesian product, the latter statement is defined as follows:

$$\text{IF } A \text{ THEN } B \text{ ELSE } C \triangleq A \times B + (\neg A \times C) \quad (5.9)$$

in which  $+$  stands for the union of the fuzzy relations  $A \times B$  and  $(\neg A \times C)$ .

More generally, if  $A_1, \dots, A_n$  are fuzzy subsets of  $U$ , and  $B_1, \dots, B_n$  are fuzzy subsets of  $V$ , then<sup>①</sup>

$$\text{IF } A_1 \text{ THEN } B_1 \text{ ELSE IF } A_2 \text{ THEN } B_2 \dots \text{ ELSE IF } A_n \text{ THEN } B_n \\ \triangleq A_1 \times B_1 + A_2 \times B_2 + \dots + A_n \times B_n. \quad (5.10)$$

Note that (5.10) reduces to (5.9) if IF  $A$  THEN  $B$  ELSE  $C$  is interpreted as IF  $A$  THEN  $B$  ELSE IF  $\neg A$  then  $C$ . It should also be noted that by repeated application of (5.9) we obtain

$$\text{if } A \text{ then (if } B \text{ then } C \text{ else } D) \text{ else } E \\ = A \times B \times C + A \times \neg B \times D + \neg A \times E. \quad (5.11)$$

If we regard IF  $A$  THEN  $B$  as IF  $A$  THEN  $B$  ELSE  $C$  with unspecified  $C$ , then, depending on the assumption made about  $C$ , various interpretations of IF  $A$  THEN  $B$  will result. In particular, if we assume that  $C = V$ , then IF  $A$  THEN  $B$  (or  $A \Rightarrow B$ ) becomes<sup>②</sup>

$$A \Rightarrow B \triangleq \text{if } A \text{ then } B \triangleq A \times B + (\neg A \times V). \quad (5.12)$$

If, in addition, we set  $A = U$  in (5.12), we obtain as an alternative definition

$$A \Rightarrow B \triangleq U \times B + (\neg A \times V). \quad (5.13)$$

① It should be noted that, in the sense used in ALGOL, the right-hand side of (5.10) would be expressed as  $A_1 \times B_1 + (\neg A_1 \cap A_2) \times B_2 + \dots + (\neg A_1 \cap \dots \cap \neg A_{n-1} \cap A_n) \times B_n$  when the  $A_i$  and  $B_i$ ,  $i = 1, \dots, n$ , are nonfuzzy sets.

② This definition should be viewed as tentative in a nature.

In the sequel, we shall assume that  $C=V$ , and hence that  $A \Rightarrow B$  is defined by (5.12). In effect, the assumption that  $C=V$  implies that, in the absence of an indication to the contrary, the consequent of  $\neg A \Rightarrow C$  can be any fuzzy subset of the universe of discourse. As a very simple illustration of (5.12), suppose that  $A$  and  $B$  are defined by (5.5) and (5.6). Then, on substituting (5.8) in (5.12), the relation matrix for  $A \Rightarrow B$  is found to be

$$A \Rightarrow B = \begin{bmatrix} 0.6 & 0.9 & 1 \\ 0.6 & 0.8 & 0.8 \end{bmatrix}.$$

It should be observed that when  $A, B$ , and  $C$  are nonfuzzy sets, we have the identity

$$\text{IF } A \text{ THEN } B \text{ ELSE } C = (\text{IF } A \text{ THEN } B) \cap (\text{IF } \neg A \text{ THEN } C) \quad (5.14)$$

which holds only approximately for fuzzy  $A, B$ , and  $C$ . This indicates that, in relation to (5.15), the definitions of IF  $A$  THEN  $B$  ELSE  $C$  and IF  $A$  THEN  $B$ , as expressed by (5.9) and (5.12), are not exactly consistent for fuzzy  $A, B$ , and  $C$ . It should also be noted that if 1)  $U=V$ , 2)  $x=y$ , and 3)  $A \Rightarrow B$  holds for all points in  $U$ , then, by (5.12),

$$A \Rightarrow B \text{ implies and is implied by } A \subset B \quad (5.15)$$

exactly if  $A$  and  $B$  are nonfuzzy and approximately otherwise.

As will be seen in Section VI, fuzzy conditional statements play a basic role in fuzzy algorithms. More specifically, a typical problem which is encountered in the course of execution of such algorithms is the following. We have a fuzzy relation say,  $R$ , from  $U$  to  $V$  which is defined by a fuzzy conditional statement. Then, we are given a fuzzy subset of  $U$ , say,  $x$ , and have to determine the fuzzy subset of  $V$ , say,  $y$ , which is induced in  $V$  by  $x$ . For

example, we may have the following two statements.

1)  $x$  is *very small*

2) IF  $x$  is *small* THEN  $y$  is *large* ELSE  $y$  is *not very large*  
of which the second defines by (5.9) a fuzzy relation  $R$ . The question, then, is as follows: What will be the value of  $y$  if  $x$  is *very small*? The answer to this question is provided by the following rule of inference, which may be regarded as an extension of the familiar rule of *modus ponens*.

*Compositional Rule of Inference*: If  $R$  is a fuzzy relation from  $U$  to  $V$ , and  $x$  is a fuzzy subset of  $U$ , then the fuzzy subset  $y$  of  $V$  which is induced by  $x$  is given by the composition (see (2.22)) of  $R$  and  $x$ ; that is,

$$y = x \circ R \quad (5.16)$$

in which  $x$  plays the role of a unary relation. <sup>①</sup>

As a simple illustration of (5.16), suppose that  $R$  and  $x$  are defined by the relation matrices in (5.17). Then  $y$  is given by the max-min product of  $x$  and  $R$ :

$$\begin{array}{ccc} x & R & y \\ [0.2 \quad 1 \quad 0.3] \circ \begin{bmatrix} 0.8 & 0.9 & 0.2 \\ 0.6 & 1 & 0.4 \\ 0.5 & 0.8 & 1 \end{bmatrix} & = & [0.6 \quad 1 \quad 0.4]. \end{array} \quad (5.17)$$

As for the question raised before, suppose that, as in (4.3), we have

$$U = 1 + 2 + 3 + 4 + 5 \quad (5.18)$$

---

<sup>①</sup> If  $R$  is visualized as a fuzzy graph, then (5.16) may be viewed as the expression for the fuzzy ordinate  $y$  corresponding to a fuzzy abscissa  $x$ .

with *small* and *large* defined by (4.2) and (4.7), respectively. Then, substituting *small* for *A*, *large* for *B* and *not very large* for *C* in (5.9), we obtain the relation matrix *R* for the fuzzy conditional statement IF *small* THEN *large* ELSE *not very large*. The result of the composition of *R* with  $x = \textit{very small}$  is

$$\begin{aligned}
 & \begin{matrix} & & x & & \\ & & [1 & 0.64 & 0.36 & 0.16 & 0.04] & \cdot & \begin{matrix} R \\ \left[ \begin{array}{ccccc} 0.2 & 0.4 & 0.6 & 0.8 & 1 \\ 0.2 & 0.4 & 0.6 & 0.8 & 0.8 \\ 0.4 & 0.4 & 0.6 & 0.6 & 0.6 \\ 0.6 & 0.6 & 0.6 & 0.4 & 0.4 \\ 0.8 & 0.8 & 0.64 & 0.36 & 0.2 \end{array} \right] \end{matrix} \\
 & = \begin{matrix} & & y & & \\ & & [0.36 & 0.4 & 0.6 & 0.8 & 1] & . \end{matrix} \end{aligned} \quad (5.19)
 \end{aligned}$$

There are several aspects of (5.16) that are in need of comment. First, it should be noted that when  $R = A \Rightarrow B$  and  $x = A$  we obtain

$$y = A \cdot (A \Rightarrow B) = B \quad (5.20)$$

as an exact identity, when *A*, *B*, and *C* are nonfuzzy, and an approximate one, when *A*, *B*, and *C* are fuzzy. It is in this sense that the compositional inference rule (5.16) may be viewed as an approximate extension of *modus ponens*. (Note that in consequence of the way in which  $A \Rightarrow B$  is defined in (5.12), the more different *x* is from *A*, the less sharply defined is *y*.)

Second, (5.16) is analogous to the expression for the marginal probability in terms of the conditional probability function; that is

$$r_j = \sum_i q_i p_{ij} \quad (5.21)$$

where

$$\begin{aligned} q_i &= \Pr\{X = x_i\} \\ r_j &= \Pr\{Y = y_j\} \\ p_{ij} &= \Pr\{Y = y_j | X = x_i\} \end{aligned}$$

and  $X$  and  $Y$  are random variables with values  $x_1, x_2, \dots$  and  $y_1, y_2, \dots$ , respectively. However, this analogy does not imply that (5.16) is a relation between probabilities.

Third, it should be noted that because of the use of the max-min matrix product in (5.16), the relation between  $x$  and  $y$  is not continuous. Thus, in general, a small change in  $x$  would produce no change in  $y$  until a certain threshold is exceeded. This would not be the case if the composition of  $x$  with  $R$  were defined as max-product composition.

Fourth, in the computation of  $x \circ R$  one may take advantage of the distributivity of composition over the union of fuzzy sets. Thus, if

$$x = u \text{ or } v \tag{5.22}$$

where  $u$  and  $v$  are labels of fuzzy sets, then

$$(u \text{ or } v) \circ R = u \circ R \text{ or } v \circ R. \tag{5.23}$$

For example, if  $x$  is *small or medium*, and  $R = A \Rightarrow B$  reads IF  $x$  is *not small and not large* THEN  $y$  is *very small*, then we can write

$$\begin{aligned} &(\textit{small or medium}) \circ (\textit{not small and not large} \Rightarrow \textit{very small}) \\ &= \textit{small} \circ (\textit{not small and not large} \Rightarrow \textit{very} \\ &\textit{small}) \end{aligned}$$

$$\textit{or medium} \circ (\textit{not small and not large} \Rightarrow \textit{very small}) \tag{5.24}$$

As a final comment, it is important to realize that in practical applications of fuzzy conditional statements to the description of complex or ill-defined relations, the computations involved in



(5. 9), (5. 10), and (5. 16) would, in general, be performed in a highly approximate fashion. Furthermore, an additional source of imprecision would be the result of representing a fuzzy set as a value of a linguistic variable. For example, suppose that a relation between fuzzy variables  $x$  and  $y$  is described by the fuzzy conditional statement IF *small* THEN *large* ELSE IF *medium* THEN *medium* ELSE IF *large* THEN *very small*.

Typically, we would assign different linguistic values to  $x$  and compute the corresponding values of  $y$  by the use of (5. 16). Then, on approximating to the computed values of  $y$  by linguistic labels, we would arrive at a table having the form shown below:

Given		Inferred	
<i>A</i>	<i>B</i>	<i>x</i>	<i>y</i>
<i>small</i>	<i>large</i>	<i>not small</i>	<i>not very large</i>
<i>medium</i>	<i>medium</i>	<i>very small</i>	<i>very very large</i>
<i>large</i>	<i>very small</i>	<i>very very small</i>	<i>very very large</i>
		<i>not very large</i>	<i>small or medium</i>

Such a table constitutes an approximate linguistic characterization of the relation between  $x$  and  $y$  which is inferred from the given fuzzy conditional statement. As was stated earlier, fuzzy conditional statements play a basic role in the description and execution of fuzzy algorithms. We turn to this subject in the following section.

## 6. Fuzzy algorithms

Roughly speaking, a fuzzy algorithm is an ordered set of fuzzy instructions which upon execution yield an approximate

solution to a specified problem. In one form or another fuzzy algorithms pervade much of what we do. Thus, we employ fuzzy algorithms both consciously and subconsciously when we walk, drive a car, search for an object, tie a knot, park a car, cook a meal, find a number in a telephone directory, etc. Furthermore, there are many instances of uses of what, in effect, are fuzzy algorithms in a wide variety of fields, especially in programming, operations research, psychology, management science, and medical diagnosis.

The notion of a fuzzy set and, in particular, the concept of a fuzzy conditional statement provide a basis for using fuzzy algorithms in a more systematic and hence more effective ways than was possible in the past. Thus, fuzzy algorithms could become an important tool for an approximate analysis of systems and decision processes which are much too complex for the application of conventional techniques.

A formal characterization of the concept of a fuzzy algorithm can be given in terms of the notion of a fuzzy Turing machine or a fuzzy Markoff algorithm [6]~[8]. In this section, the main aim of our discussion is to relate the concept of a fuzzy algorithm to the notions introduced in the preceding sections and illustrate by simple examples some of the uses of such algorithms.

The instructions in a fuzzy algorithm fall into the following three classes.

1) *Assignment Statements*: e. g. ,

$x \approx 5$

$x = \textit{small}$

$x \textit{ is large}$

*x is not large and not very small.*

2) *Fuzzy Conditional Statements*: e. g. ,

IF *x is small* THEN *y is large* ELSE *y is not large*

IF *x is positive* THEN decrease *y slightly*

IF *x is much greater than 5* THEN stop

IF *x is very small* THEN go to 7.

Note that in such statements either the antecedent or the consequent or both may be labels of fuzzy sets.

3) *Unconditional Action Statements*: e. g. ,

multiply *x* by *x*

decrease *x slightly*

delete the first *few* occurrences of 1

go to 7

print *x*

stop.

Note that some of these instructions are fuzzy and some are not.

The combination of an assignment statement and a fuzzy conditional statement is executed in accordance with the compositional rule (5.16). For example, if at some point in the execution of a fuzzy algorithm we encounter the instructions

1)  $x = \textit{very small}$

2) IF *x is small* THEN *y is large* ELSE *y is not very large*  
where *small* and *large* are defined by (4.2) and (4.7), then the result of the execution of 1) and 2) will be the value of *y* given by (5.19), that is,

$$y = 0.36/1 + 0.4/2 + 0.64/3 + 0.8/4 + 1/5. \quad (6.1)$$

An unconditional but fuzzy action statement is executed similarly. For example, the instruction

multiply  $x$  by itself a *few* times (6.2)

with *few* defined as

$$few = 1/1 + 0.8/2 + 0.6/3 + 0.4/4 \quad (6.3)$$

would yield upon execution the fuzzy set

$$y = 1/x^2 + 0.8/x^3 + 0.6/x^4 + 0.4/x^5. \quad (6.4)$$

It is important to observe that, in both (6.1) and (6.4), the result of execution is a fuzzy set rather than a single number. However, when a human subject is presented with a fuzzy instruction such as "take *several* steps," with *several* defined by (see(2.10))

$$several = 0.5/3 + 0.8/4 + 1/5 + 1/6 + 0.8/7 + 0.5/8 \quad (6.5)$$

the result of execution must be a single number between 3 and 8. On what basis will such a number be chosen?

As pointed out in [6], it is reasonable to assume that the result of execution will be that element of the fuzzy set which has the highest grade of membership in it. If such an element is not unique, as is true of (6.5), then a random or arbitrary choice can be made among the elements having the highest grade of membership. Alternatively, an external criterion can be introduced which linearly orders those elements of the fuzzy set which have the highest membership, and thus generates a unique greatest element. For example, in the case of (6.5), if the external criterion is to minimize the number of steps that have to be taken, then the subject will pick 5 from the elements with the highest grade of membership.

An analogous question arises in situations in which a human subject has to give a "yes" or "no" answer to a fuzzy question. For example, suppose that a subject is presented with the instruction

IF  $x$  is *small* THEN stop ELSE go to 7 (6.6)

in which *small* is defined by (4.2). Now assume that  $x=3$ , which has the grade of membership of 0.6 in *small*. Should the subject execute "stop" or "go to 7"? We shall assume that in situations of this kind the subject will pick that alternative which is more true than untrue, e. g. , " $x$  is *small*" over " $x$  is *not small*," since in our example the degree of truth of the statement "3 is *small*" is 0.6, which is greater than that of the statement "3 is *not small*." If both alternatives have more or less equal truth values, the choice can be made arbitrarily. For convenience, we shall refer to this rule of deciding between two alternatives as the *rule of the preponderant alternative*.

It is very important to understand that the questions just discussed arise only in those situations in which the result of execution of a fuzzy instruction is required to be a single element (e. g. , a number) rather than a fuzzy set. Thus, if we allowed the result of execution of (6.6) to be fuzzy, then for  $x=3$  we would obtain the fuzzy set

$$0.6/\text{stop} + 0.4/\text{go to 7}$$

which implies that the execution is carried out in parallel. The assumption of parallelism is implicit in the compositional rule of inference and is basic to the understanding of fuzzy algorithms and their execution by humans and machines.

In what follows, we shall present several examples of fuzzy algorithms in the light of the concepts discussed in the preceding sections. It should be stressed that these examples are intended primarily to illustrate the basic aspects of fuzzy algorithms rather than demonstrate their effectiveness in the solution of practical

problems.

It is convenient to classify fuzzy algorithms into several basic categories, each corresponding to a particular type of application; definitional and identificational algorithms; generational algorithms; relational and behavioral algorithms; and decisional algorithms. (It should be noted that an algorithm of a particular type can include algorithms of other types as subalgorithms. For example, a definitional algorithm may contain relational and decisional subalgorithms.) We begin with an example of a definitional algorithm.

### *Fuzzy Definitional Algorithms*

One of the basic areas of application for fuzzy algorithms lies in the definition of complex, ill-defined or fuzzy concepts in terms of simpler or less fuzzy concepts. The following are examples of such fuzzy concepts; sparseness of matrices; handwritten characters; measures of complexity; measures of proximity or resemblance; degrees of clustering; criteria of performance; soft constraints; rules of various kinds, e. g. , zoning regulations; legal criteria, e. g. , criteria for insanity, obscenity, etc. ; and fuzzy diseases such as arthritis, arteriosclerosis, schizophrenia.

Since a fuzzy concept may be viewed as a label for a fuzzy set, a *fuzzy definitional algorithm* is, in effect, a finite set of possibly fuzzy instructions which define a fuzzy set in terms of other fuzzy sets (and possibly itself, i. e. , recursively.) or constitute a procedure for computing the grade of membership of any element of the universe of discourse in the set under definition. In the latter case, the definational algorithm plays the

role of an *identificational algorithm*, that is, an algorithm which identifies whether or not an element belongs to a set or, more generally, determines its grade of membership. An example of such an algorithm is provided by the procedure (see [5]) for computing the grade of membership of a string in a fuzzy language generated by a context-free grammar.

As a very simple example of a fuzzy definitional algorithm, we shall consider the fuzzy concept *oval*. It should be emphasized again that the oversimplified definition that will be given is intended only for illustrative purposes and has no pretense at being an accurate definition of the concept *oval*. The instructions comprising the algorithm OVAL are listed here. The symbol  $T$  in these instructions stands for the object under test. The term call CONVEX represents a call on a subalgorithm labeled CONVEX, which is a definitional algorithm for testing whether or not  $T$  is convex. An instruction of the form IF  $A$  THEN  $B$  should be interpreted as IF  $A$  THEN  $B$  ELSE go to next instruction.

*Algorithm OVAL:*

- 1) IF  $T$  is not closed then  $T$  is not *oval*; stop.
- 2) IF  $T$  is self-intersecting then  $T$  is not *oval*; stop.
- 3) IF  $T$  is not call CONVEX THEN  $T$  is not *oval*; stop.
- 4) IF does not have two *more or less* orthogonal axes of symmetry THEN  $T$  is not *oval*; stop.
- 5) IF the major axis of  $T$  is not *much* longer Than the minor axis THEN  $T$  is not *oval*; stop.
- 6)  $T$  is *oval*; stop.

*Subalgorithm CONVEX:* Basically, this subalgorithm involves a check on whether the curvature of  $T$  at each point

maintains the same sign as one moves along  $T$  in some initially chosen direction.

- 1)  $x = a$  (some initial point on  $T$ ).
- 2) Choose a direction of movement along  $T$ .
- 3)  $t \approx$  direction of tangent to  $T$  at  $x$ .
- 4)  $x' \approx x + 1$  (move from  $x$  to a neighboring point).
- 5)  $t' \approx$  direction of tangent to  $T$  at  $x'$ .
- 6)  $\alpha \approx$  angle between  $t'$  and  $t$ .
- 7)  $x \approx x'$ .
- 8)  $t \approx$  direction of tangent to  $T$  at  $x$ .
- 9)  $x' \approx x + 1$ .
- 10)  $t' \approx$  direction of tangent to  $T$  at  $x'$ .
- 11)  $\beta \approx$  angle between  $t'$  and  $t$ .
- 12) IF  $\beta$  does not have the same sign as  $\alpha$  THEN  $T$  is not convex; return.
- 13) IF  $x' \approx a$  THEN  $T$  is convex; return.
- 14) Go to 7).

*Comment:* It should be noted that the first three instructions in OVAL are nonfuzzy. As for instructions 4) and 5), they involve definitions of concepts such as "more or less orthogonal," and "much longer," which, though fuzzy, are less complex and better understood than the concept of *oval*. This exemplifies the main function of a fuzzy definitional algorithm, namely, to reduce a new or complex fuzzy concept to simpler or better understood fuzzy concepts. In a more elaborate version of the algorithm OVAL, the answers to 4) and 5) could be the degrees to which the conditions in these instructions are satisfied. The final result of the algorithm, then, would be the grade of membership of  $T$  in



the fuzzy set of oval objects.

In this connection, it should be noted that, in virtue of (5.15), the algorithm OVAL as stated is approximately equivalent to the expression

$$\begin{aligned} oval = & \text{closed} \cap \text{non-self-intersecting} \cap \text{convex} \\ & \cap \text{more or less orthogonal axes of symmetry} \\ & \cap \text{major axis } \textit{much} \text{ larger than minor axis} \quad (6.7) \end{aligned}$$

which defines the fuzzy set *oval* as the intersection of the fuzzy and nonfuzzy sets whose labels appear on the right-hand side of (6.7). However, one significant difference is that the algorithm not only defines the right-hand side of (6.7), but also specifies the order in which the computations implicit in (6.7) are to be performed.

### *Fuzzy Generational Algorithms*

As its designation implies, a fuzzy generational algorithm serves to generate rather than define a fuzzy set. Possible applications of generational algorithms include; generation of handwritten characters and patterns of various kinds; cooking recipes; generation of music; generation of sentences in a natural language; generation of speech.

As a simple illustration of the notion of a generational algorithm, we shall consider an algorithm for generating the letter **P**, with the height  $h$  and the base  $b$  of **P** constituting the parameters of the algorithm. For simplicity, **P** will be generated as a dotted pattern, with eight dots lying on the vertical line.

*Algorithm P* ( $h, b$ ):

1)  $i = 1$ .

- 2)  $X(i) = b$  (first dot at base).
- 3)  $X(i+1) \approx X(i) + h/6$  (put dot *approximately*  $h/6$  units of distance above  $X(i)$ ).
- 4)  $i = i + 1$ .
- 5) IF  $i = 7$  THEN make right turn and go to 7).
- 6) Go to 3.
- 7) Move by  $h/6$  units; put a dot.
- 8) Turn by  $45^\circ$ , move by  $h/6$  units; put a dot.
- 9) Turn by  $45^\circ$ , move by  $h/6$  units; put a dot.
- 10) Turn by  $45^\circ$ , move by  $h/6$  units; put a dot.
- 11) Turn by  $45^\circ$ , move by  $h/6$  units; put a dot; stop.

The algorithm as stated is of open-loop type in the sense that it does not incorporate any feedback. To make the algorithm less sensitive to errors in execution, we could introduce fuzzy feedback by conditioning the termination of the algorithm on an approximate satisfaction of a specified test. For example, if the last point in step 11) does not fall on the vertical part of  $P$ , we could return to step 8) and either reduce or increase the angle of turn in steps 8) ~ 11) to correct for the terminal error. The flowchart of a cooking recipe for chocolate fudge, which is given in [19], is a good example of what, in effect, is a fuzzy generational algorithm with feedback.

### *Fuzzy Relational and Behavioral Algorithms*

A *fuzzy relational algorithm* serves to describe a relation or relations between fuzzy variables. A relational algorithm which is used for the specific purpose of approximate description of the behavior of a system will be referred to as a *fuzzy behavioral*

*algorithm.*

A simple example of a relational algorithm labeled  $R$  which involves three parameters  $x$ ,  $y$ , and  $z$  is given. This algorithm defines a fuzzy ternary relation  $R$  in the universe of discourse  $U = 1 + 2 + 3 + 4 + 5$  with *small* and *large* defined by (4.2) and (4.7).

*Algorithm  $R(x, y, z)$ :*

- 1) IF  $x$  is *small* and  $y$  is *large* THEN  $z$  is *very small* ELSE  $z$  is *not small*.
- 2) IF  $x$  is *large* THEN (IF  $y$  is *small* THEN  $z$  is *very large* ELSE  $z$  is *small*) ELSE  $z$  and  $y$  are *very very small*.

If needed, the meaning of these conditional statements can be computed by using (5.9) and (5.11). The relation  $R$ , then, will be the intersection of the relations defined by instructions 1) and 2).

Another simple example of a relational fuzzy algorithm  $F(x, y)$  which illustrates a different aspect of such algorithms is the following.

*Algorithm  $F(x, y)$ :*

- 1) IF  $x$  is *small* and  $x$  is increased *slightly* THEN  $y$  will increase *slightly*.
- 2) IF  $x$  is *small* and  $x$  is increased *substantially* THEN  $y$  will increase *substantially*.
- 3) IF  $x$  is *large* and  $x$  is increased *slightly* THEN  $y$  will increase *moderately*.
- 4) IF  $x$  is *large* and  $x$  is increased *substantially* THEN  $y$  will increase *very substantially*.

As in the case of the previous example, the meaning of the

fuzzy conditional statements in this algorithm can be computed by the use of the methods discussed in Sections IV and V if one is given the definitions of the primary terms *large* and *small* as well as the hedges *slightly*, *substantially*, and *moderately*.

As a simple example of a behavioral algorithm, suppose that we have a system  $S$  with two nonfuzzy states (see [3]) labeled  $q_1$  and  $q_2$ , two fuzzy input values labeled *low* and *high*, and two fuzzy output values labeled *large* and *small*. The universe of discourse for the input and output values is assumed to be the real line. We assume further that the behavior of  $S$  can be characterized in an approximate fashion by the algorithm that will be given. However, to represent the relations between the inputs, states, and outputs, we use the conventional state transition tables instead of conditional statements.

*Algorithm BEHAVIOR:*

$u_t$	$x_t$	$x_{t+1}$		$y_t$	
		$q_1$	$q_2$	$q_1$	$q_2$
<i>low</i>		$q_2$	$q_1$	<i>large</i>	<i>small</i>
<i>high</i>		$q_1$	$q_1$	<i>small</i>	<i>large</i>

where

$u_t$  input at time  $t$

$y_t$  output at time  $t$

$x_t$  state at time  $t$ .

On the surface, this table appears to define a conventional nonfuzzy finite-state system. What is important to recognize, however, is that in the case of the system under consideration

the inputs and outputs are fuzzy subsets of the real line. Thus we could pose the question; What would be the output of  $S$  if it is in state  $q_1$  and the applied input is *very low*? In the case of  $S$ , this question can be answered by an application of the compositional inference rule(5.16). On the other hand, the same question would not be a meaningful one if  $S$  is assumed to be a nonfuzzy finite-state system characterized by the preceding table.

Behavioral fuzzy algorithms can also be used to describe the more complex forms of behavior resulting from the presence of random elements in a system. For example, the presence of random elements in  $S$  might result in the following fuzzy-probabilistic characterization of its behavior;

$x_t$ $u_t$	$x_{t+1}$		$y_t$	
	$q_1$	$q_2$	$q_1$	$q_2$
<i>low</i>	$q_1$ likely	$q_1$ likely	<i>large</i> <i>likely</i>	<i>small</i> <i>likely</i> <sup>2</sup>
<i>high</i>	$q_1$ likely <sup>2</sup>	$q_1$ unlikely <sup>2</sup>	<i>small</i> <i>likely</i> <sup>2</sup>	<i>large</i> <i>unlikely</i> <sup>2</sup>

In this table, the term *likely* and its modifications by *very* and *not* serve to provide an approximate characterization of probabilities. For example, IF the input is *low* and the present state is  $q_1$ , THEN the next state is *likely* to be  $q_2$ . Similarly, IF the input is *high* and the present state is  $q_2$  THEN the output is *very unlikely* to be *large*. If the meaning of *likely* is defined by (see (4.16))

$$\begin{aligned}
 \text{likely} = & 1/1 + 1/0.9 + 1/0.8 + 0.8/0.7 + 0.6/0.6 \\
 & + 0.5/0.5 + 0.3/0.4 + 0.2/0.3 \quad (6.8)
 \end{aligned}$$

then

$$\begin{aligned} \text{unlikely} = & 0.2/0.7 + 0.4/0.6 + 0.5/0.5 + 0.7/0.4 \\ & + 0.8/0.3 + 1/0.2 + 1/0.1 + 1/0 \end{aligned} \quad (6.9)$$

$$\begin{aligned} \text{very likely} \approx & 1/1 + 1/0.9 + 1/0.8 + 0.6/0.7 + 0.4/0.6 \\ & + 0.3/0.5 + 0.1/0.4 \end{aligned} \quad (6.10)$$

$$\begin{aligned} \text{very unlikely} \approx & 0.2/0.6 + 0.3/0.5 + 0.5/0.4 + 0.6/0.3 \\ & + 1/0.2 + 1/0.1 + 1/0. \end{aligned} \quad (6.11)$$

### *Fuzzy Decisional Algorithms*

A *fuzzy decisional algorithm* is a fuzzy algorithm which serves to provide an approximate description of a strategy or decision rule. Commonplace examples of such algorithms, which we use for the most part on a subconscious level, are the algorithms for parking a car, crossing an intersection, transferring an object, buying a house, etc.

To illustrate the notion of a fuzzy decisional algorithm, we shall consider two simple examples drawn from our everyday experiences.

*Example—Crossing a traffic intersection:* It is convenient to break down the algorithm in question into several subalgorithms, each of which applies to a particular type of intersection. For our purposes, it will be sufficient to describe only one of these subalgorithms, namely, the subalgorithm SIGN, which is used when the intersection has a stop sign. As in the case of other examples in this section, we shall make a number of simplifying assumptions in order to shorten the description of the algorithm.

*Algorithm INTERSECTION:*

1) IF signal lights THEN call SIGNAL ELSE IF stop sign THEN call SIGN ELSE IF blinking light THEN call BLINKING flse CALL UNCONTROLLED

*Subalgorithm SIGN:*

1) IF no stop sign on your side THEN IF no cars in the intersection THEN cross at *normal* speed ELSE wait for cars to leave the intersection and then cross.

2) IF not *close* to intersection THEN continue approaching at normal speed for a *few* seconds; go to 2).

3) *Slow down.*

4) IF in a *great* hurry and no police cars in sight and no cars in the intersection or its *vicinity* THEN cross the intersection at *slow* speed.

5) IF *very close* to intersection THEN stop; go to 7).

6) Continue *approaching* at *very slow* speed; go to 5).

7) IF no cars *approaching* or in the intersection THEN cross.

8) Wait a *few* seconds; go to 7).

It hardly needs saying that a realistic version of this algorithm would be considerably more complex. The important point of the example is that such an algorithm could be constructed along the same lines as the highly simplified version just described. Furthermore, it shows that a fuzzy algorithm could serve as an effective means of communicating know-how and experience.

As a final example, we consider a decisional algorithm for transferring a blindfolded subject *H* from an initial position *start* to a final position *goal* under the assumption that there may be

an obstacle lying between *start* and *goal* (see Fig. 4). (Highly sophisticated nonfuzzy algorithms of this type for use by robots are incorporated in Shakey, the robot built by the Artificial Intelligence Group at Stanford Research Institute. A description of this robot is given in [20].)

The algorithm, labeled OBSTACLE, is assumed to be used by a human controller *C* who can observe the way in which *H* executes his instructions. This fuzzy feedback plays an essential role in making it possible for *C* to direct *H* to *goal* in spite of the fuzziness of instructions as well as the errors in their execution by *H*. The algorithm OBSTACLE consists of three subalgorithms: ALIGN, HUG, and STRAIGHT. The function of STRAIGHT is to transfer *H* from *start* to an intermediate goal *I-goal*<sub>1</sub>, and then from *I-goal*<sub>2</sub> to *goal*. (See Fig. 3) The function of ALIGN is to orient *H* in a desired direction; the function of HUG is to guide *H* along the boundary of the obstacle until the goal is no longer obstructed.

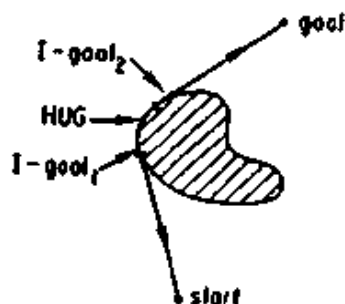

Fig. 3. Problem of transferring blindfolded subject from *start* to *goal*.

Instead of describing these subalgorithms in terms of fuzzy conditional statements as we have done in previous examples, it is instructive to convey the same information by flowcharts, as



shown in Figs. 4 ~ 6. In the flowchart of ALIGN,  $\epsilon$  denotes the error in alignment, and we assume for simplicity that  $\epsilon$  has a constant sign. The flowcharts of HUG and STRAIGHT are self-explanatory. Expressed in terms of fuzzy conditional statements, the flowchart of STRAIGHT, for example, translates into the following instructions.

*Subalgorithm STRAIGHT:*

- 1) IF not *close* THEN take a step; go to 1).
- 2) IF not *very close* THEN take a *small* step; go to 2).
- 3) IF not *very very close* THEN take a *very small* step; go to 3).
- 4) Stop.

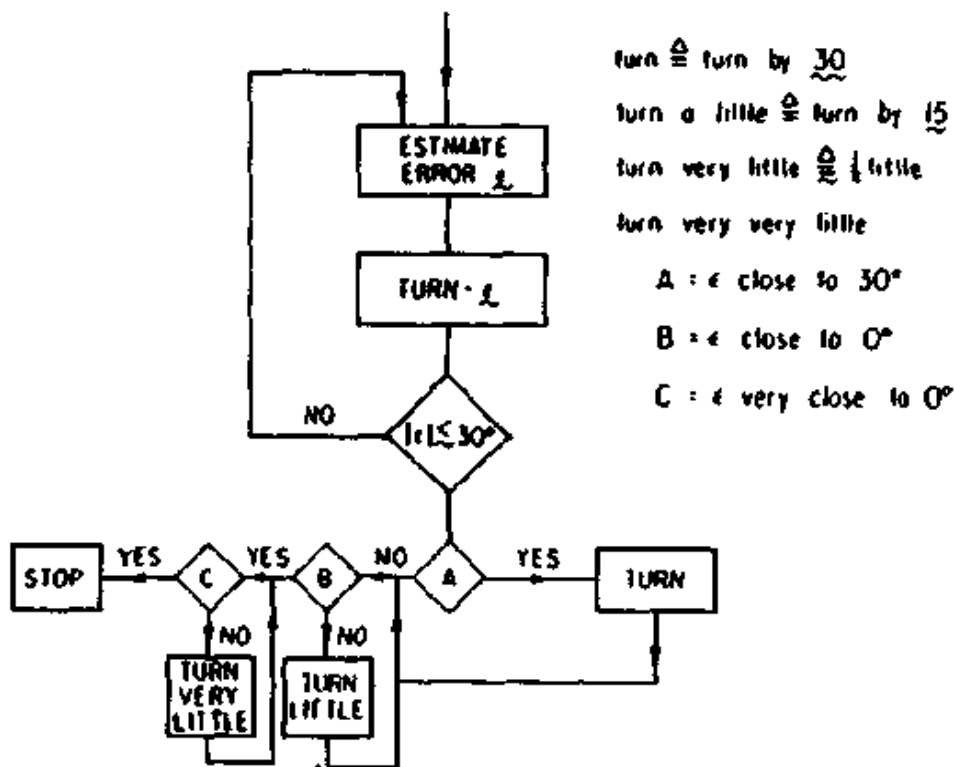

Fig. 4. Subalgorithm ALIGN.

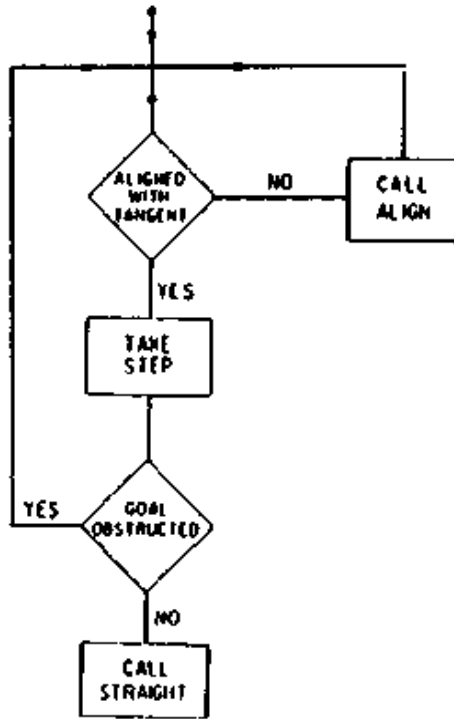

Fig. 5. Subalgorithm HUG.

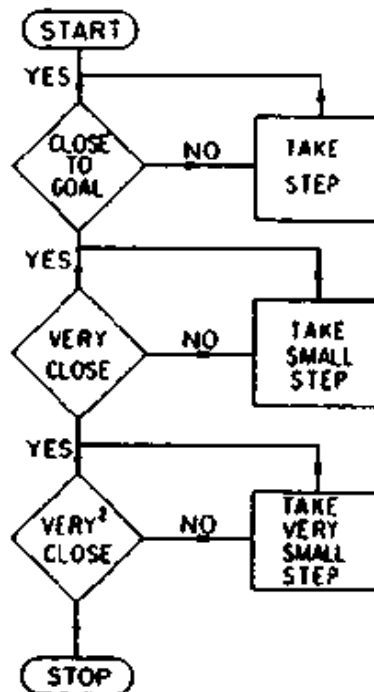

Fig. 6. Subalgorithm STRAIGHT.

## 7. Concluding Remarks

In this and the preceding sections of this paper, we have attempted to develop a conceptual framework for dealing with systems which are too complex or too ill-defined to admit of precise quantitative analysis. What we have done should be viewed, of course, as merely a first tentative step in this direction. Clearly, there are many basic as well as detailed aspects of our approach which we have treated incompletely, if at all. Among these are questions relation to the role of fuzzy feedback in; the execution of fuzzy algorithms; the execution of fuzzy algorithms by humans; the conjunction of fuzzy instructions; the assessment of the goodness of fuzzy algorithms; the implications of the compositional rule of inference and the rule of the preponderant alternative; and the interplay between fuzziness and probability in the behavior of humanistic systems.

Nevertheless, even at its present stage of development, the method described in this paper can be applied rather effectively to the formulation and approximate solution of a wide variety of practical problems, particularly in such fields as economics, management science, psychology, linguistics, taxonomy, artificial intelligence, information retrieval, medicine, and biology. This is particularly true of those problem areas in these fields in which fuzzy algorithms can be drawn upon to provide a means of description of ill-defined concepts, relations, and decision rules.

## References

- [1] L. A. Zadeh, "fuzzy sets," *Inform. Contr.*, vol. 8, pp. 338~353, 1965.
- [2] —, "Similarity relations and fuzzy orderings," *inform. Sci.*, vol. 3, pp. 177~200, 1971.
- [3] —, "Toward a theory of fuzzy systems," in *Aspects of Network and System Theory*, R. E. Kalman and N. DeClaris, Eds. New York; Holt, Rinehart and Winston, 1971.
- [4] —, "Quantitative fuzzy semantics," *Inform. Sci.*, vol. 3, pp. 159~176, 1971.
- [5] —, "Fuzzy languages and their relation to human and machine intelligence," in *Proc. Conf. Man and Computer*, 1970; also *Electron. Res. Lab., Univ. California, Berkeley, Memo. M-302*, 1971.
- [6] —, "Fuzzy algorithms," *Inform. Contr.*, vol. 12, pp. 94~102, 1968.
- [7] E. Santos, "Fuzzy algorithms," *Inform. Contr.*, vol. 17, pp. 326~339, 1970.
- [8] L. A. Zadeh, "On fuzzy algorithms," *Electron. Res. lab., Univ. California, Berkeley, Memo. M-325*, 1971.
- [9] S.-K. Chang, "On the execution of fuzzy programs using finite-state machines," *IEEE Trans. Comput.*, vol. C-21, pp. 241~253, Mar. 1972.
- [10] S. S. L. Chang and L. A. Zadeh, "Fuzzy mapping and control," *IEEE Trans. Syst., Man, Cybern.*, vol. SMC-2, pp. 30~34, Jan. 1962.
- [11] R. E. Bellman and L. A. Zadeh, "Decision-making in a fuzzy environment," *Management Sci.*, vol. 17, pp. B-141-B-164, 1970.
- [12] J. A. Goguen, "The logic of inexact concepts," *Syn.*, vol. 19, pp. 325~373, 1969.
- [13] G. Lakoff, "Hedges: a study in meaning criteria and the logic of fuzzy concepts," in *Proc. 8th Reg. Meet. Chicago Linguist. Soc.*, 1972.

- [14] L. A. Zadeh, "A system-theoretic view of behavior modification," Electron. Res. Lab., Univ. California, Berkeley, Memo. M-320, 1972.
- [15] — "A fuzzy-set-theoretic interpretation of hedges," Electron. Res. Lab., Univ. California, Berkeley, Memo. M-335, 1972.
- [16] A. De Luca and S. Termini, "A definition of a non-probabilistic entropy in the setting of fuzzy sets theory," *Inform. Contr.*, vol. 20, pp. 301~312, 1972.
- [17] R. C. T. Lee, "Fuzzy logic and the resolution principle," *J. Ass. Comput. Mach.*, vol. 19, pp. 109~119, 1972.
- [18] G. E. Hughes and M. J. Cresswell, *An Introduction to Modal Logic*. London; Methuen, 1968.
- [19] R. S. Ledley, *Fortran IV Programming*. New York; McGraw-Hill, 1966.
- [20] B. Raphael, R. Duda, R. E. Fikes, P. E. Hart, N. Nilsson, P. W. Thorndyke, and B. M. Wilbur, "Research and applications — artificial intelligence," Stanford Res. Inst., Menlo Park, Calif., Final Rep., Oct. 1971.



Part 3: Linguistic variable  
and approximate reasoning

---





# The Concept of a Linguistic Variable and its Application to Approximate Reasoning- I

## 1. Introduction

One of the fundamental tenets of modern science is that a phenomenon cannot be claimed to be well understood until it can be characterized in quantitative terms.<sup>①</sup> Viewed in this perspective, much of what constitutes the core of scientific knowledge may be regarded as a reservoir of concepts and techniques which can be drawn upon to construct mathematical models of various types of systems and thereby yield quantitative information concerning their behavior.

Given our veneration for what is precise, rigorous and quantitative, and our disdain for what is fuzzy, unrigorous and qualitative, it is not surprising that the advent of digital computers has resulted in a rapid expansion in the use of quantitative methods throughout most fields of human knowledge. Unquestionably, computers have proved to be highly effective in dealing with

---

<sup>①</sup> As expressed by Lord Kelvin in 1883[1], "In physical science a first essential step in the direction of learning any subject is to find principles of numerical reckoning and practicable methods for measuring some quality connected with it. I often say that when you can measure what you are speaking about and express it in numbers, you know something about it; but when you cannot measure it, when you cannot express it in numbers, your knowledge is of a meagre and unsatisfactory kind; it may be the beginning of knowledge but you have scarcely, in your thoughts, advanced to the state of *science*, whatever the matter may be."

*mechanistic* systems, that is, with inanimate systems whose behavior is governed by the laws of mechanics, physics, chemistry and electromagnetism. Unfortunately, the same cannot be said about *humanistic* systems,<sup>①</sup> which—so far at least—have proved to be rather impervious to mathematical analysis and computer simulation. Indeed, it is widely agreed that the use of computers has not shed much light on the basic issues arising in philosophy, psychology, literature, law, politics, sociology and other human-oriented fields. Nor have computers added significantly to our understanding of human thought processes—excepting, perhaps, some examples to the contrary that can be drawn from artificial intelligence and related fields[2,3,4,5,51].

It may be argued, as we have done in [6] and [7], that the ineffectiveness of computers in dealing with humanistic systems is a manifestation of what might be called the *principle of incompatibility*—a principle which asserts that high precision is incompatible with high complexity.<sup>②</sup> Thus, it may well be the case that the conventional techniques of system analysis and computer simulation—based as they are on precise manipulation of numerical data—are intrinsically incapable of coming to grips with the great complexity of human thought processes and decision-making. The acceptance of this premise suggests that, in

---

① By a *humanistic* system we mean a system whose behavior is strongly influenced by human judgement, perception or emotions. Examples of humanistic systems are, economic systems, political systems, legal systems, educational systems, etc. A single individual and his thought processes may also be viewed as a humanistic system.

② Stated somewhat more concretely, the complexity of a system and the precision with which it can be analyzed bear a roughly inverse relation to one another.

order to be able to make significant assertions about the behavior of humanistic systems, it may be necessary to abandon the high standards of rigor and precision that we have become conditioned to expect of our mathematical analyses of well-structured mechanistic systems, and become more tolerant of approaches which are approximate in nature. Indeed, it is entirely possible that only through the use of such approaches could computer simulation become truly effective as a tool for the analysis of systems which are too complex or too ill-defined for the application of conventional quantitative techniques.

In retreating from precision in the face of overpowering complexity, it is natural to explore the use of what might be called *linguistic variables*, that is, variables whose values are not numbers but words or sentences in a natural or artificial language. The motivation for the use of words or sentences rather than numbers is that linguistic characterizations are, in general, less specific than numerical ones. For example, in speaking of age, when we say "John is young," we are less precise than when we say, "John is 25." In this sense, the label *young* may be regarded as a *linguistic value* of the variable *Age*, with the understanding that it plays the same role as the numerical value 25 but is less precise and hence less informative. The same is true of the linguistic values *very young*, *not young*, *extremely young*, *not very young*, etc. as contrasted with the numerical values 20, 21, 22, 23, ...

If the values of a numerical variable are visualized as points in a plane, then the values of a linguistic variable may be likened to ball parks with fuzzy boundaries. In fact, it is by virtue of the

employment of ball parks rather than points that linguistic variables acquire the ability to serve as a means of approximate characterization of phenomena which are too complex or too ill-defined to be susceptible of description in precise terms. What is also important, however, is that by the use of a so-called *extension principle*, much of the existing mathematical apparatus of systems analysis can be adapted to the manipulation of linguistic variables. In this way, we may be able to develop an approximate calculus of linguistic variables which could be of use in a wide variety of practical applications.

The totality of values of a linguistic variable constitute its *term-set*, which in principle could have an infinite number of elements. For example, the term-set of the linguistic variable *Age* might read

$$T(\textit{Age}) = \textit{young} + \textit{not young} + \textit{very young} + \textit{not very young} + \textit{very very young} + \dots + \textit{old} + \textit{not old} + \textit{very old} + \textit{not very old} + \dots + \textit{not very young and not very old} + \dots + \textit{middle-aged} + \textit{not middle-aged} + \dots + \textit{not old and not middle-aged} + \dots + \textit{extremely old} + \dots, \quad (1.1)$$

in which + is used to denote the union rather than the arithmetic sum. Similarly, the term-set of the linguistic variable *Appearance* might be

$$T(\textit{Appearance}) = \textit{beautiful} + \textit{pretty} + \textit{cute} + \textit{handsome} + \textit{attractive} + \textit{not beautiful} + \textit{very pretty} + \textit{very very handsome} + \textit{more or less pretty} + \textit{quite pretty} + \textit{quite handsome} + \textit{fairly handsome} + \textit{not very attractive and not very unattractive} + \dots$$

In the case of the linguistic variable *Age*, the numerical variable

*age* whose values are the numbers  $0, 1, 2, 3, \dots, 100$  constitutes what may be called the *base variable* for *Age*. In terms of this variable, a linguistic value such as *young* may be interpreted as a label for a *fuzzy restriction* on the values of the base variable. This fuzzy restriction is what we take to be the *meaning* of *young*.

A fuzzy restriction on the values of the base variable is characterized by a *compatibility function* which associates with each value of the base variable a number in the interval  $[0, 1]$  which represents its *compatibility* with the fuzzy restriction. For example, the compatibilities of the numerical ages 22, 28 and 35 with the fuzzy restriction labeled *young* might be 1, 0.7 and 0.2, respectively. The meaning of *young*, then, would be represented by a graph of the form shown in Fig. 1, which is a plot of the compatibility function of *young* with respect to the base variable *age*.

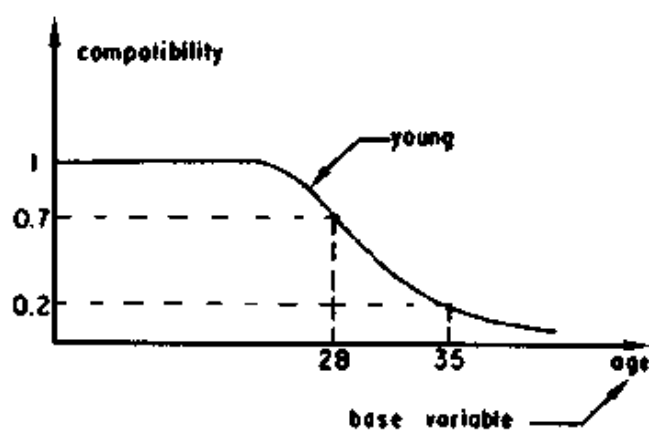

Fig. 1. Compatibility function for *young*.

The conventional interpretation of the statement "John is young," is that John is a member of the class of young men.

However, considering that the class of young men is a fuzzy set, that is, there is no sharp transition from being young to not being young, the assertion that John is a member of the class of young men is inconsistent with the precise mathematical definition of "is a member of." The concept of a linguistic variable allows us to get around this difficulty in the following manner.

The name "John" is viewed as a name of a composite linguistic variable whose components are linguistic variables named *Age*, *Height*, *Weight*, *Appearance*, etc. Then the statement "John is young" is interpreted as an *assignment equation* (Fig. 2).

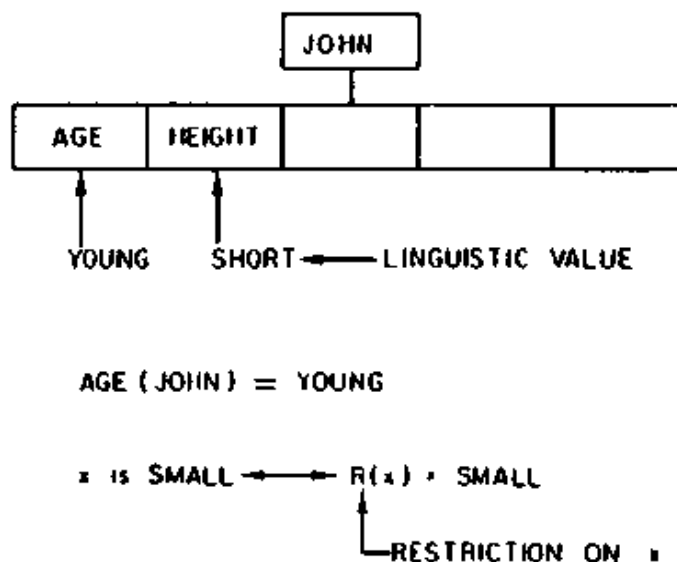

Fig. 2. Assignment of linguistic values to attributes of John and  $x$ .

$$Age = young$$

which assigns the value *young* to the linguistic variable *Age*. In turn, the value *young* is interpreted as a label for a fuzzy restriction on the base variable *age*, with the meaning of this fuzzy restriction defined by its compatibility function. As an aid

in the understanding of the concept of a linguistic variable, Fig. 3 shows the hierarchical structure of the relation between the linguistic variable *Age*, the fuzzy restrictions which represent the meaning of its values, and the values of the base variable *age*.

There are several basic aspects of the concept of a linguistic variable that are in need of elaboration.

First, it is important to understand that the notion of compatibility is distinct from that of probability. Thus, the statement that the compatibility of, say, 28 with *young* is 0.7, has no relation to the probability of the age-value 28. The correct interpretation of the compatibility-value 0.7 is that it

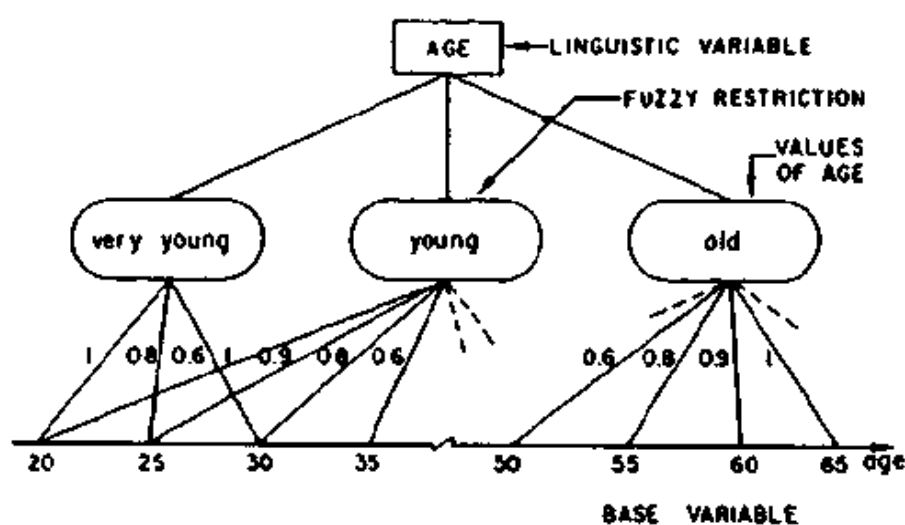

Fig. 3. Hierarchical structure of a linguistic variable.

is merely a subjective indication of the extent to which the age-value 28 fits one's conception of the label *young*. As we shall see in later sections, the rules of manipulation applying to compatibilities are different from those applying to probabilities, although there are certain parallels between the two.

Second, we shall usually assume that a linguistic variable is *structured* in the sense that it is associated with two rules. Rule (i), a *syntactic rule*, specifies the manner in which the linguistic values which are in the term-set of the variable may be generated. In regard to this rule, our usual assumption will be that the terms in the term-set of the variable are generated by a context-free grammar.

The second rule, (ii), is a *semantic rule* which specifies a procedure for computing the meaning of any given linguistic value. In this connection, we observe that a typical value of a linguistic variable, e. g. , *not very young and not very old*, involves what might be called the *primary* terms, e. g. , *young* and *old*, whose meaning is both subjective and context-dependent. We assume that the meaning of such terms is specified *a priori*.

In addition to the primary terms, a linguistic value may involve connectives such as *and*, *or*, *either*, *neither*, etc. ; the negation *not*; and the hedges such as *very*, *more or less*, *completely*, *quite*, *fairly*, *extremely*, *somewhat*, etc. As we shall see in later sections, the connectives, the hedges and the negation may be treated as operators which modify the meaning of their operands in a specified, context-independent fashion. Thus, if the meaning of *young* is defined by the compatibility function whose form is shown in Fig. 1, then the meaning of *very young* could be obtained by squaring the compatibility function of *young*, while that of *not young* would be given by subtracting the compatibility function of *young* from unity (Fig. 4). These two rules are special instances of a more general semantic rule which is described in Part II, Sec. 2.



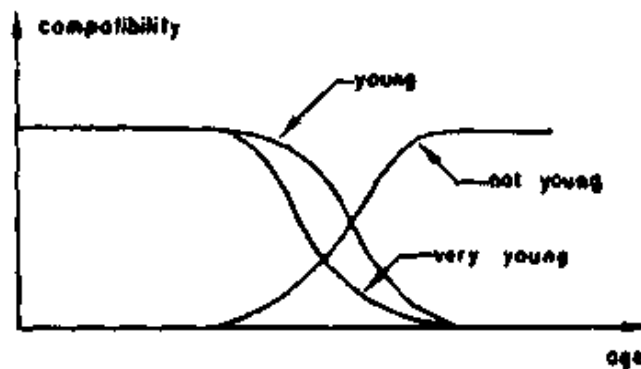

Fig. 4. Compatibilities of *young*, *not young*, and *very young*.

Third, when we speak of a linguistic variable such as *Age*, the underlying base variable, *age*, is numerical in nature. Thus, in this case we can define the meaning of a linguistic value such as *young* by a compatibility function which associates with each age in the interval  $[0, 100]$  a number in the interval  $[0, 1]$  which represents the compatibility of that age with the label *young*.

On the other hand, in the case of the linguistic variable *Appearance*, we do not have a well-defined base variable; that is, we do not know how to express the degree of beauty, say, as a function of some physical measurements. We could still associate with each member of a group of ladies, for example, a grade of membership in the class of beautiful women, say 0.9 with Fay, 0.7 with Adele, 0.8 with Kathy and 0.9 with Vera, but these values of the compatibility function would be based on impressions which we may not be able to articulate or formalize in explicit terms. In other words, we are defining the compatibility function not on a set of mathematically well-defined objects, but on a set of labeled impressions. Such

definitions are meaningful to a human but not—at least directly—to a computer. ①

As we shall see in later sections, in the first case, where the base variable is numerical in nature, linguistic variables can be treated in a reasonably precise fashion by the use of the extension principle for fuzzy sets. In the second case, their treatment becomes much more qualitative. In both cases, however, some computation is involved—to a lesser or greater degree. Thus, it should be understood that the linguistic approach is not entirely qualitative in nature. Rather, the computations are performed behind the scene, and, at the end, *linguistic approximation* is employed to convert numbers into words (Fig. 5).

A particularly important area of application for the concept of a linguistic variable is that of *approximate reasoning*, by which we mean a type of reasoning which is neither very precise nor very imprecise. As an illustration, the following inference would be an instance of approximate reasoning:

$x$  is small,  
 $x$  and  $y$  are approximately equal;  
therefore,  
 $y$  is more or less small.

The concept of a linguistic variable enters into approximate reasoning as a result of treating *Truth* as a linguistic variable whose truth-values form a term-set such as shown below:

$$T(\text{Truth}) = \text{true} + \text{not true} + \text{very true} + \text{completely true} +$$

---

① The basic problem which is involved here is that of abstraction from a set of samples of elements of a fuzzy set. A discussion of this problem may be found in [8].

more or less true + fairly true + essentially true +  
 ... + false + very false + neither true nor false +  
 ...

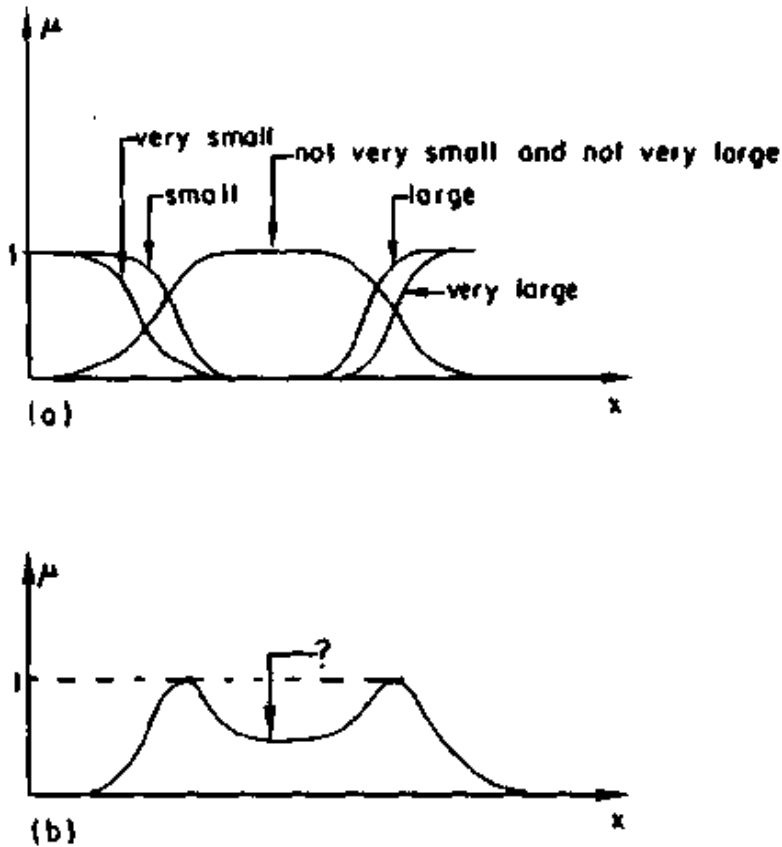

Fig. 5. (a) Compatibilities of *small*, *very small*, *large*, *very large* and *not very small and not very large*. (b) The problem of linguistic approximation is that of finding an approximate linguistic characterization of a given compatibility function.

The corresponding base variable, then, is assumed to be a number in the interval  $[0, 1]$ , and the meaning of a primary term such as *true* is identified with a fuzzy restriction on the values of the base variable. As usual, such a restriction is characterized by a compatibility function which associates a number in the interval  $[0, 1]$  with each numerical truth-value. For example, the

compatibility of the numerical truth-value 0.7 with the linguistic truth-value *very true* might be 0.6. Thus, in the case of truth-values, the compatibility function is a mapping from the unit interval to itself. (This will be shown in Part I, Fig. 13.)

Treating truth as a linguistic variable leads to a fuzzy logic which may well be a better approximation to the logic involved in human decision processes than the classical two-valued logic.<sup>①</sup> Thus, in fuzzy logic it is meaningful to assert what would be inadmissibly vague in classical logic, e. g. ,

The truth-value of "Berkeley is close to San Francisco,"  
is *quite true*.

The truth-value of "Palo Alto is close to San Francisco,"  
is *fairly true*.

Therefore,

the truth-value of "Palo Alto is more or less  
close to Berkeley," is *more or less true*.

Another important area of application for the concept of a linguistic variable lies in the realm of probability theory. If probability is treated as a linguistic variable, its term-set would typically be:

$T(\text{Probability}) = \text{likely} + \text{very likely} + \text{unlikely} + \text{extremely likely}$   
 $+ \text{fairly likely} + \dots + \text{probable} + \text{improbable} + \text{more}$   
 $\text{or less probable} + \dots$

By legitimizing the use of linguistic probability-values, we make it possible to respond to a question such as "What is the probability that it will be a warm day a week from today?" with

---

① Expositions of alternative approaches to vagueness may be found in [9~18].

an answer such as *fairly high*, instead of, say, 0.8. The linguistic answer would, in general, be much more realistic, considering, first, that *warm day* is a fuzzy event, and, second, that our understanding of weather dynamics is not sufficient to allow us to make unequivocal assertions about the underlying probabilities.

In the following sections, the concept of a linguistic variable and its applications will be discussed in greater detail. To place the concept of a linguistic variable in a proper perspective, we shall begin our discussion with a formalization of the notion of a conventional (nonfuzzy) variable. For our purposes, it will be helpful to visualize such a variable as a tagged valise with rigid (hard) sides (Fig. 6). Putting an object into the valise corresponds to assigning a value to the variable, and the restriction on what can be put in corresponds to a subset of the universe of discourse which comprises those points which can be assigned as values to the variable. In terms of this analogy, a *fuzzy variable*, which is defined in Part I, Sec. 1, may be likened to a tagged valise with soft rather than rigid sides (Part I, Fig. 1). In this case, the restriction on what can be put in is fuzzy in nature, and is defined by a compatibility function which associates with each object a number in the interval  $[0, 1]$  representing the degree of ease with which that object can be fitted in the valise. For example, given a valise named  $X$ , the compatibility of a coat with  $X$  would be 1, while that of a record-player might be 0.7.

As will be seen in Part I, Sec. 1, an important concept in the case of fuzzy variables is that of *noninteraction*, which is analogous to the concept of independence in the case of random

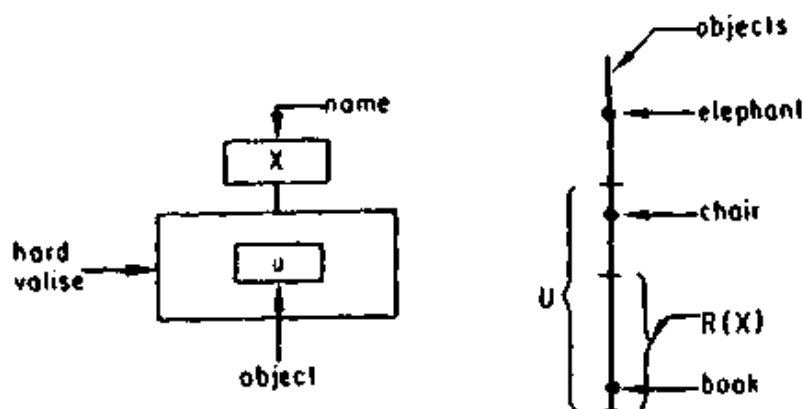

Fig. 6. Illustration of the valise analogy for a unary nonfuzzy variable.

variables. This concept arises when we deal with two or more fuzzy variables, each of which may be likened to a compartment in a soft valise. Such fuzzy variables are *interactive* if the assignment of a value to one affects the fuzzy restrictions placed on the others. This effect may be likened to the interference between objects which are put into different compartments of a soft valise (Part I, Fig. 3).

A linguistic variable is defined in Part I, Sec. 2 as a variable whose values are fuzzy variables. In terms of our valise analogy, a linguistic variable corresponds to a hard valise into which we can put soft valises, with each soft valise carrying a name tag which describes a fuzzy restriction on what can be put into that valise (Part I, Fig. 6).

The application of the concept of a linguistic variable to the notion of *Truth* is discussed in Part I, Sec. 3. Here we describe a technique for computing the conjunction, disjunction and negation for linguistic truth-values and lay the groundwork for

fuzzy logic.

In Part II, Sec. 1, the concept of a linguistic variable is applied to probabilities, and it is shown that linguistic probabilities can be used for computational purposes. However, because of the constraint that the numerical probabilities must add up to unity, the computations in question involve the solution of nonlinear programs and hence are not as simple to perform as computations involving numerical probabilities.

The last section is devoted to a discussion of the so-called *compositional rule of inference* and its application to approximate reasoning. This rule of inference is interpreted as the process of solving a simultaneous system of so-called *relational assignment equations* in which linguistic values are assigned to fuzzy restrictions. Thus, if a statement such as “ $x$  is small” is interpreted as an assignment of the linguistic value *small* to the fuzzy restriction on  $x$ , and the statement “ $x$  and  $y$  are approximately equal” is interpreted as the assignment of a fuzzy relation labeled *approximately equal* to the fuzzy restriction on the ordered pair  $(x, y)$ , then the conclusion “ $y$  is more or less small” may be viewed as a linguistic approximation to the solution of the simultaneous equations

$$R(x) = \textit{small},$$

$$R(x, y) = \textit{approximately equal},$$

in which  $R(x)$  and  $R(x, y)$  denote the restrictions on  $x$  and  $(x, y)$ , respectively (Part II, Fig. 5).

The compositional rule of inference leads to a *generalized modus ponens*, which may be viewed as an extension of the familiar rule of inference: If  $A$  is true and  $A$  implies  $B$ , then  $B$  is

true. The section closes with an example of a fuzzy theorem in elementary geometry and a brief discussion of the use of fuzzy flowcharts for the representation of definitional fuzzy algorithms.

The material in Secs. 2 and 3 and in Part I, Sec. 1 is intended to provide a mathematical basis for the concept of a linguistic variable, which is introduced in Part II, Sec. 2. For those readers who may not be interested in the mathematical aspects of the theory, it may be expedient to proceed directly to Part I, Sec. 2 and refer where necessary to the definitions and results described in the preceding sections.

## **2. The concept of a variable**

In the preceding section, our discussion of the concept of a linguistic variable was informal in nature. To set the stage for a more formal definition, we shall focus our attention in this section on the concept of a conventional (nonfuzzy) variable. Then in Sec. 3 we shall extend the concept of a variable to fuzzy variables and subsequently will define a linguistic variable as a variable whose values are fuzzy variables.

Although the concept of a (nonfuzzy) variable is very elementary in nature, it is by no means a trivial one. For our purposes, the following formalization of the concept of a variable provides a convenient basis for later extensions.

**Definition 2.1.** A variable is characterized by a triple  $(X, U, R(X;u))$ , in which  $X$  is the name of the variable;  $U$  is a universe



of discourse (finite or infinite set);  $u$  is a generic<sup>①</sup> name for the elements of  $U$ ; and  $R(X;u)$  is a subset of  $U$  which represents a *restriction*<sup>②</sup> on the values of  $u$  imposed by  $X$ . For convenience, we shall usually abbreviate  $R(X;u)$  to  $R(X)$  or  $R(u)$  or  $R(x)$ , where  $x$  denotes a generic name for the values of  $X$ , and will refer to  $R(X)$  simply as the *restriction on  $u$*  or the *restriction imposed by  $X$* .

In addition, a variable is associated with an *assignment equation*

$$x = u : R(X) \quad (2.1)$$

or equivalently

$$x = u, u \in R(X) \quad (2.2)$$

which represents the assignment of a value  $u$  to  $x$  subject to the restriction  $R(X)$ . Thus, the assignment equation is *satisfied* iff (if and only if)  $u \in R(X)$ .

*Example 2.1.* As a simple illustration consider a variable named *age*. In this case,  $U$  might be taken to be the set of integers  $0, 1, 2, 3, \dots$ , and  $R(X)$  might be the subset  $0, 1, 2, \dots, 100$ .

More generally, let  $X_1, \dots, X_n$  be  $n$  variables with respective universes of discourse  $U_1, \dots, U_n$ . The ordered  $n$ -tuple  $X = (X_1, \dots, X_n)$  will be referred to as an  *$n$ -ary composite (or joint) variable*. The universe of discourse for  $X$  is the Cartesian product

---

① A generic name is a single name for all elements of a set. For simplicity, we shall frequently use the same symbol for both a set and the generic name for its elements, relying on the context for disambiguation.

② In conventional terminology,  $R(X)$  is the range of  $X$ . Our use of the term *restriction* is motivated by the role played by  $R(X)$  in the case of fuzzy variables.

$$U = U_1 \times U_2 \times \cdots \times U_n, \quad (2.3)$$

and the restriction  $R(X_1, \dots, X_n)$  is an  $n$ -ary relation in  $U_1 \times \cdots \times U_n$ . This relation may be defined by its characteristic (membership) function  $\mu_R : U_1 \times \cdots \times U_n \rightarrow \{0, 1\}$ , where

$$\begin{aligned} \mu_R(u_1, \dots, u_n) &= 1 \quad \text{if } (u_1, \dots, u_n) \in R(X_1, \dots, X_n), \\ &= 0 \quad \text{otherwise,} \end{aligned} \quad (2.4)$$

and  $u_i$  is a generic name for the elements of  $U_i$ ,  $i = 1, \dots, n$ . Correspondingly, the  $n$ -ary assignment equation assumes the form

$$(x_1, \dots, x_n) = (u_1, \dots, u_n) : R(X_1, \dots, X_n), \quad (2.5)$$

which is understood to mean that

$$x_i = u_i, \quad i = 1, \dots, n \quad (2.6)$$

subject to the restriction  $(u_1, \dots, u_n) \in R(X_1, \dots, X_n)$ , with  $x_i$ ,  $i = 1, \dots, n$ , denoting a generic name for values of  $X_i$ .

*Example 2.2* Suppose that  $X_1 \triangleq$  age of father,  ${}^{\textcircled{1}}X_2 \triangleq$  age of son, and  $U_1 \triangleq U_2 = \{1, 2, \dots, 100\}$ . Furthermore, suppose that  $x_1 \geq x_2 + 20$  ( $x_1$  and  $x_2$  are generic names for values of  $X_1$  and  $X_2$ ). Then  $R(X_1, X_2)$  may be defined by

$$\begin{aligned} \mu_R(u_1, u_2) &= 1 \quad \text{for } 21 \leq u_1 \leq 100, u_1 \geq u_2 + 20 \\ &= 0 \quad \text{elsewhere.} \end{aligned} \quad (2.7)$$

### *Marginal and conditioned restrictions*

As in the case of probability distributions, the restriction  $R(X_1, \dots, X_n)$  imposed by  $(X_1, \dots, X_n)$  induces *marginal* restrictions

---

<sup>①</sup> The symbol  $\triangleq$  stands for "denotes" or is "equal by definition."

$R(X_{i_1}, \dots, X_{i_k})$  imposed by composite variables of the form  $(X_{i_1}, \dots, X_{i_k})$ , where the index sequence  $q = (i_1, \dots, i_k)$  is a subsequence of the index sequence  $(1, 2, \dots, n)$ . <sup>①</sup>In effect,  $R(X_{i_1}, \dots, X_{i_k})$  is the smallest (i. e., most restrictive) restriction imposed by  $(X_{i_1}, \dots, X_{i_k})$  which satisfies the implication

$$\begin{aligned} & (u_1, \dots, u_n) \in R(X_1, \dots, X_n) \\ \Rightarrow & (u_{i_1}, \dots, u_{i_k}) \in R(X_{i_1}, \dots, X_{i_k}). \end{aligned} \quad (2.8)$$

Thus, a given  $k$ -tuple  $u_{(q)} \triangleq (u_{i_1}, \dots, u_{i_k})$  is an element of  $R(X_{i_1}, \dots, X_{i_k})$  iff there exists an  $n$ -tuple  $u \triangleq (u_1, \dots, u_n) \in R(X_1, \dots, X_n)$  whose  $i_1$  th,  $\dots$ ,  $i_k$  th components are equal to  $u_{i_1}, \dots, u_{i_k}$ , respectively. Expressed in terms of the characteristic functions of  $R(X_1, \dots, X_n)$  and  $R(X_{i_1}, \dots, X_{i_k})$ , this statement translates into the equation

$$\begin{aligned} & \mu_{R(X_{i_1}, \dots, X_{i_k})}(u_{i_1}, \dots, u_{i_k}) = \\ & \bigvee_{u_{(q')}} \mu_{R(X_1, \dots, X_n)}(u_1, \dots, u_n), \end{aligned} \quad (2.9)$$

or more compactly

$$\mu_{R(X_{(q)})}(u_{(q)}) = \bigvee_{u_{(q')}} \mu_{R(X)}(u), \quad (2.10)$$

where  $q'$  is the complement of the index sequence  $q = (i_1, \dots, i_k)$  relative to  $(1, \dots, n)$ ,  $u_{(q')}$  is the complement of the  $k$ -tuple  $u_{(q)} \triangleq (u_{i_1}, \dots, u_{i_k})$  relative to the  $n$ -tuple  $u \triangleq (u_1, \dots, u_n)$ ,  $X_{(q)} \triangleq (X_{i_1}, \dots, X_{i_k})$ , and  $\bigvee_{u_{(q'')}}$  denotes the supremum of its operand over the  $u$ 's which are in  $u_{(q')}$ . (Throughout this paper, the symbols  $\bigvee$  and  $\bigwedge$  stand for Max and Min, respectively; thus,

---

<sup>①</sup> In the case of a binary relation  $R(X_1, X_2)$ ,  $R(X_1)$  and  $R(X_2)$  are usually referred to as the *domain* and *range* of  $R(X_1, X_2)$ .

for any real,  $a, b$

$$\begin{aligned} a \vee b = \text{Max}(a, b) &= a && \text{if } a \geq b \\ &= b && \text{if } a < b \end{aligned} \quad (2.11)$$

and

$$\begin{aligned} a \wedge b = \text{Min}(a, b) &= a && \text{if } a \leq b \\ &= b && \text{if } a > b. \end{aligned}$$

Consistent with this notation, the symbol  $\vee_z$  should be read as "supremum over the values of  $z$ ." Since  $\mu_R$  can take only two values — 0 or 1 — (2.10) means that  $\mu_{R(X_{(q)})}(u_{(q)})$  is 1 iff there exists a  $u_{(q)}$  such that  $\mu_{R(X)}(u) = 1$ .

Comment 2.1. There is a simple analogy which is very helpful in clarifying the notion of a variable and related concepts. Specifically, a nonfuzzy variable in the sense formalized in Definition 2.1 may be likened to a tagged valise having rigid (hard) sides, with  $X$  representing the name on the tag,  $U$  representing a list of objects which could be put in a valise, and  $R(X)$  representing a sublist of  $U$  which comprises those objects which can be put into valise  $X$ . [For example, an object like a boat would not be in  $U$ , while an object like a typewriter might be in  $U$  but not in  $R(X)$ , and an object like a cigarette box or a pair of shoes would be in  $R(X)$ .] In this interpretation, the assignment equation

$$x = u : R(X)$$

signifies that an object  $u$  which satisfies the restriction  $R(X)$  (i. e., is on the list of objects which can be put into  $X$ ) is put into  $X$  (Fig. 6).

An  $n$ -ary composite variable  $X \triangleq (X_1, \dots, X_n)$  corresponds to a valise, carrying the name-tag  $X$ , which has  $n$  compartments

named  $X_1, \dots, X_n$  with adjustable partitions between them. The restrictions  $R(X_1, \dots, X_n)$  corresponds to a list of  $n$ -tuples of objects  $(u_1, \dots, u_n)$  such that  $u_1$  can be put in compartment  $X_1, u_2$  in compartment  $X_2, \dots,$  and  $u_n$  in compartment  $X_n$  *simultaneously*. (see Fig. 7.) In this connection, it should be noted that  $n$ -tuples on this list could be associated with different arrangements of partitions. If  $n=2$ , for example, then for a particular placement of the partition we could put a coat in compartment  $X_1$  and a suit in compartment  $X_2$ , while for some other placement we could put the coat in compartment  $X_2$  and a box of shoes in compartment  $X_1$ . In this event, both (coat, suit) and (shoes, coat) would be included in the list of pairs of objects which can be put in  $X$  simultaneously.

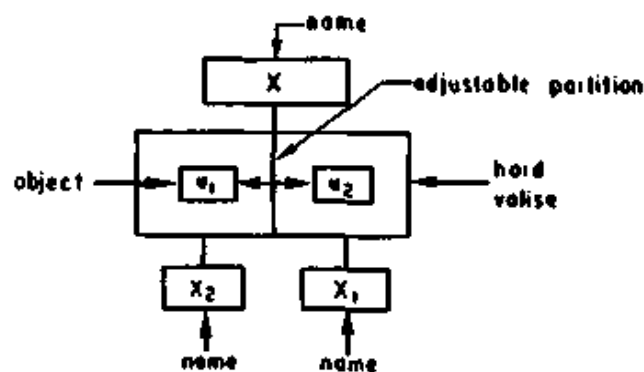

Fig. 7. Valise analogy for a binary nonfuzzy variable.

In terms of the valise analogy, the  $n$ -ary assignment equation

$$(x_1, \dots, x_n) = (u_1, \dots, u_n) : R(X_1, \dots, X_n)$$

represents the action of putting  $u_1$  in  $X_1, \dots,$  and  $u_n$  in  $X_n$  simultaneously, under the restriction that the  $n$ -tuple of objects  $(u_1, \dots, u_n)$  must be on the  $R(X_1, \dots, X_n)$  list. Furthermore, a marginal restriction such as  $R(X_1, \dots, X_i)$  may be interpreted as a list of  $k$ -tuples of objects which can be put in compartments

$X_{i_1}, \dots, X_{i_k}$  simultaneously, in conjunction with every allowable placement of objects in the remaining compartments.

Comment 2.2. It should be noted that (2.9) is analogous to the expression for a marginal distribution of a probability distribution, with  $\vee$  corresponding to summation (or integration). However, this analogy should not be construed to imply that  $R(X_{i_1}, \dots, X_{i_k})$  is in fact a marginal probability distribution.

It is convenient to view the right-hand side of (2.9) as the characteristic function of the projection <sup>①</sup> of  $R(X_1, \dots, X_n)$  on  $U_{i_1} \times \dots \times U_{i_k}$ . Thus, in symbols,

$$R(X_{i_1}, \dots, X_{i_k}) = \text{Proj } R(X_1, \dots, X_n) \text{ on } U_{i_1} \times \dots \times U_{i_k}, \quad (2.12)$$

or more simply,

$$R(X_{i_1}, \dots, X_{i_k}) = P_q R(X_1, \dots, X_n),$$

where  $P_q$  denotes the operation of projection on  $U_{i_1} \times \dots \times U_{i_k}$  with  $q = (i_1, \dots, i_k)$ .

*Example 2.3.* In the case of Example 2.2, we have

$$R(X_1) = P_1 R(X_1, X_2) = \{21, \dots, 100\},$$

$$R(X_2) = P_2 R(X_1, X_2) = \{1, \dots, 80\}.$$

*Example 2.4.* Fig. 8 shows the restrictions on  $u_1$  and  $u_2$  induced by  $R(X_1, X_2)$ .

An alternative way of describing projections is the

---

<sup>①</sup> The term *projection* as used in the literature is somewhat ambiguous in that it could denote either the operation of projecting or the result of such an operation. To avoid this ambiguity in the case of fuzzy relations, we will occasionally employ the term *shadow* [19] to denote the relation resulting from applying an operation of projection to another relation.

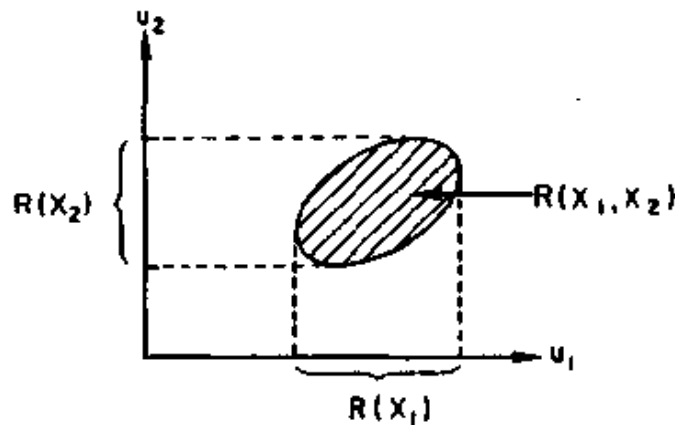

Fig. 8. Marginal restrictions induced by  $R(X_1, X_2)$ .

following. Viewing  $R(X_1, \dots, X_n)$  as a relation in  $U_1 \times \dots \times U_n$ , let  $q' = (j_1, \dots, j_m)$  denote the index sequence complementary to  $q = (i_1, \dots, i_k)$ , and let  $R(X_{i_1}, \dots, X_{i_k} | u_{j_1}, \dots, u_{j_m})$ —or, more compactly,  $R(X_{(q)} | u_{(q')})$ —denote a restriction in  $U_{i_1} \times \dots \times U_{i_k}$  which is *conditioned on*  $u_{j_1}, \dots, u_{j_m}$ . The characteristic function of this conditioned restriction is defined by

$$\mu_{R(X_{i_1}, \dots, X_{i_k} | u_{j_1}, \dots, u_{j_m})}(u_{i_1}, \dots, u_{i_k}) = \mu_{R(X_1, \dots, X_n)}(u_1, \dots, u_n), \quad (2.13)$$

or more simply [see (2.10)],

$$\mu_{R(X_{(q)} | u_{(q')})}(u_{(q)}) = \mu_{R(X)}(u)$$

with the understanding that the arguments  $u_{j_1}, \dots, u_{j_m}$  on the right-hand side of (2.13) are treated as parameters. In consequence of this understanding, although the characteristic function of the conditioned restriction is numerically equal to that of  $R(X_1, \dots, X_n)$ , it defines a relation in  $U_{i_1} \times \dots \times U_{i_k}$  rather than in  $U_1 \times \dots \times U_n$ .

In view of (2.9), (2.12) and (2.13), the projection of  $R(X_1, \dots, X_n)$  on  $U_{i_1} \times \dots \times U_{i_k}$  may be expressed as

$$P_q R(X_1, \dots, X_n) = \bigcup_{u_{(q)}} R(X_{i_1}, \dots, X_{i_k} | u_{j_1}, \dots, u_{j_m}). \quad (2.14)$$

where  $\bigcup_{u_{(q)}}$  denotes the union of the family of restrictions  $R(X_{i_1}, \dots, X_{i_k} | u_{j_1}, \dots, u_{j_m})$  parametrized by  $u_{(q)} \triangleq (u_{j_1}, \dots, u_{j_m})$ . Consequently, (2.14) implies that the marginal restriction  $R(X_{i_1}, \dots, X_{i_k})$  in  $U_{i_1} \times \dots \times U_{i_k}$  may be expressed as the union of conditioned restrictions  $R(X_{i_1}, \dots, X_{i_k} | u_{j_1}, \dots, u_{j_m})$  i. e. ,

$$R(X_{i_1}, \dots, X_{i_k}) = \bigcup_{u_{(q)}} R(X_{i_1}, \dots, X_{i_k} | u_{j_1}, \dots, u_{j_m}), \quad (2.15)$$

or more compactly,

$$R(X_{(q)}) = \bigcup_{u_{(q)}} R(X_{(q)} | u_{(q)}).$$

*Example 2.5.* As a simple illustration of (2.15), assume that  $U_1 = U_2 \triangleq \{3, 5, 7, 9\}$  and that  $R(X_1, X_2)$  is characterized by the following relation matrix. [In this matrix, the  $(i, j)$  th entry is 1 iff the ordered pair ( $i$ th element of  $U_1$ ,  $j$ th element of  $U_2$ ) belongs to  $R(X_1, X_2)$ . In effect, the relation matrix of a relation  $R$  constitutes a tabulation of the characteristic function of  $R$ . ]

$R$	3	5	7	9
3	0	0	1	0
5	1	0	1	0
7	1	0	1	1
9	1	0	0	1

In this case,

$$R(X_1, X_2 | u_1 = 3) = \{7\},$$

$$R(X_1, X_2 | u_1 = 5) = \{3, 7\},$$

$$R(X_1, X_2 | u_1 = 7) = \{3, 7, 9\},$$

$$R(X_1, X_2 | u_1 = 9) = \{3, 9\},$$

and hence

$$R(X_2) = \{7\} \cup \{3, 7\} \cup \{3, 7, 9\} \cup \{3, 9\}$$



$$= \{3, 7, 9\}.$$

### *Interaction and noninteraction*

A basic concept that we shall need in later sections is that of the *interaction* between two or more variables—a concept which is analogous to the *dependence* of random variables. More specifically, let the variable  $X = (X_1, \dots, X_n)$  be associated with the restriction  $R(X_1, \dots, X_n)$ , which induces the restrictions  $R(X_1), \dots, R(X_n)$  on  $u_1, \dots, u_n$ , respectively. Then we have

**Definition 2.2.**  $X_1, \dots, X_n$  are *noninteractive variables under*  $R(X_1, \dots, X_n)$  iff  $R(X_1, \dots, X_n)$  is *separable*, i. e. ,

$$R(X_1, \dots, X_n) = R(X_1) \times \dots \times R(X_n), \quad (2.16)$$

where, for  $i = 1, \dots, n$ ,

$$\begin{aligned} R(X_i) &= \text{Proj } R(X_1, \dots, X_n) \text{ on } U_i \\ &= \bigcup_{u_{(q)}} R(X_i | u_{(q)}), \end{aligned} \quad (2.17)$$

with  $u_{(q)} \triangleq u_i$  and  $u_{(q)} \triangleq$  complement of  $u_i$  in  $(u_1, \dots, u_n)$ .

**Example 2.6.** Fig. 9(a) shows two noninteractive variables  $X_1$  and  $X_2$  whose restrictions  $R(X_1)$  and  $R(X_2)$  are intervals, in this case,  $R(X_1, X_2)$  is the Cartesian product of the intervals in question. In Fig. 9(b),  $R(X_1, X_2)$  is a proper subset of  $R(X_1) \times R(X_2)$ , and hence  $X_1$  and  $X_2$  are interactive. Note that in Example 2.3,  $X_1$  and  $X_2$  are interactive.

As will be shown in a more general context in part I, Sec. 1, if  $X_1, \dots, X_n$  are noninteractive, then an  $n$ -ary assignment equation

$$(x_1, \dots, x_n) = (u_1, \dots, u_n) : R(X_1, \dots, X_n) \quad (2.18)$$

can be decomposed into a sequence of  $n$  unary assignment equations

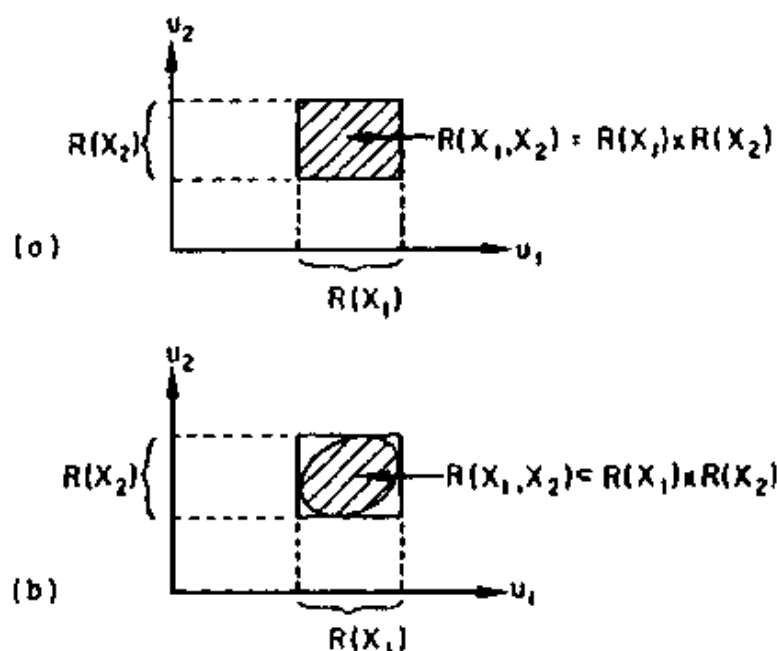

Fig. 9. (a)  $X_1$  and  $X_2$  are noninteractive.

(b)  $X_1$  and  $X_2$  are interactive.

$$\begin{aligned}
 x_1 = u_1 &: R(X_1), \\
 x_2 = u_2 &: R(X_2), \\
 \vdots & \quad \quad \quad \vdots \\
 x_n = u_n &: R(X_n).
 \end{aligned}
 \tag{2.19}$$

where  $R(X_i), i = 1, \dots, n$ , is the projection of  $R(X_1, \dots, X_n)$  on  $U_i$ , and by Definition 2.2,

$$R(X_1, \dots, X_n) = R(X_1) \times \dots \times R(X_n). \tag{2.20}$$

In the case where  $X_1, \dots, X_n$  are interactive, the sequence of  $n$  unary assignment equations assumes the following form [see also Part I, Eq. (1.34)].

$$\left. \begin{aligned} x_1 = u_1 &: R(X_1), \\ x_2 = u_2 &: R(X_2 | u_1), \\ \vdots & \quad \quad \quad \vdots \\ x_n = u_n &: R(X_n | u_1, \dots, u_{n-1}). \end{aligned} \right\} \quad (2.21)$$

where  $R(X_i | u_1, \dots, u_{i-1})$  denotes the induced restriction on  $u_i$  conditioned on  $u_1, \dots, u_{i-1}$ . The characteristic function of this conditioned restriction is expressed by [see (2.13)]

$$\mu_{R(X_i | u_1, \dots, u_{i-1})}(u_i) = \mu_{R(X_1, \dots, X_i)}(u_1, \dots, u_i), \quad (2.22)$$

with the understanding that the arguments  $u_1, \dots, u_{i-1}$  on the right-hand side of (2.22) play the role of parameters.

Comment 2.3. In words, (2.21) means that, in the case of interactive variables, once we have assigned a value  $u_1$  to  $x_1$ , the restriction on  $u_2$  becomes dependent on  $u_1$ . Then, the restriction on  $u_3$  becomes dependent on the values assigned to  $x_1$  and  $x_2$ , and, finally, the restriction on  $u_n$  becomes dependent on  $u_1, \dots, u_{n-1}$ . Furthermore, (2.22) implies that the restriction on  $u_i$  given  $u_1, \dots, u_{i-1}$  is essentially the same as the marginal restriction on  $(u_1, \dots, u_i)$ , with  $u_1, \dots, u_{i-1}$  treated as parameters. This is illustrated in Fig. 10.

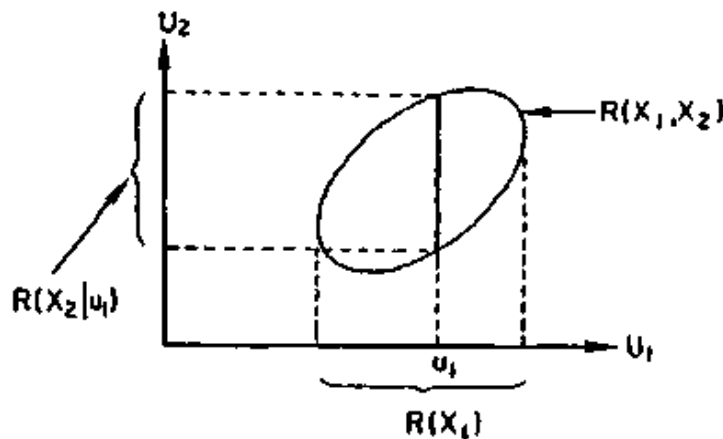

Fig. 10.  $R(X_2 | u_1)$  is the restriction on  $u_2$  conditioned on  $u_1$ .

In terms of the valise analogy (see Comment 2.1),  $X_1, \dots, X_n$  are noninteractive if the partitions between the compartments named  $X_1, \dots, X_n$  are not adjustable. In this case, what is placed in a compartment  $X_i$  has no influence on the objects that can be placed in the other compartments.

In the case where the partitions are adjustable, this is no longer true, and  $X_1, \dots, X_n$  become interactive in the sense that the placement of an object, say  $u_i$ , in  $X_i$  affects what can be placed in the complementary compartments. From this point of view, the sequence of unary assignment equations (2.21) describes the way in which the restriction on compartment  $X_i$  is influenced by the placement of objects  $u_1, \dots, u_{i-1}$  in  $X_1, \dots, X_{i-1}$ .

Our main purpose in defining the notions of noninteraction, marginal restriction, conditioned restriction, etc. for nonfuzzy variables is (a) to indicate that concepts analogous to statistical independence, marginal distribution, conditional distribution, etc., apply also to nonrandom, nonfuzzy variables; and (b) to set the stage for similar concepts in the case of fuzzy variables. As a preliminary, we shall turn our attention to some of the relevant properties of fuzzy sets and formulate an extension principle which will play an important role in later sections.

### **3. Fuzzy sets and the extension principle**

As will be seen in Part I, Sec. 1, a fuzzy variable  $X$  differs from a nonfuzzy variable in that it is associated with a restriction

$R(X)$  which is a fuzzy subset of the universe of discourse. <sup>①</sup> Consequently, as a preliminary to our consideration of the concept of a fuzzy variable, we shall review some of the pertinent properties of fuzzy sets and state an extension principle which allows the domain of a transformation or a relation in  $U$  to be extended from points in  $U$  to fuzzy subsets of  $U$ .

*Fuzzy sets-notation and terminology*

A fuzzy subset  $A$  of a universe of discourse  $U$  is characterized by a *membership function*  $\mu_A : U \rightarrow [0, 1]$  which associates with each element  $u$  of  $U$  a number  $\mu_A(u)$  in the interval  $[0, 1]$ , with  $\mu_A(u)$  representing the *grade of membership* of  $u$  in  $A$ . <sup>②</sup>The *support* of  $A$  is the set of points in  $U$  at which  $\mu_A(u)$  is positive. The *height* of  $A$  is the supremum of  $\mu_A(u)$  over  $U$ . A *crossover point* of  $A$  is a point in  $U$  whose grade of membership in  $A$  is 0.5.

*Example 3.1.* Let the universe of discourse be the interval  $[0, 1]$ , with  $u$  interpreted as *age*. A fuzzy subset of  $U$  labeled *old* may be defined by a membership function such as

$$\begin{aligned} \mu_A(u) &= 0, & \text{for } 0 \leq u \leq 50, & & (3.1) \\ \mu_A(u) &= \left[ 1 + \left( \frac{u-50}{5} \right)^{-2} \right]^{-1}, & \text{for } 50 \leq u \leq 100. & \end{aligned}$$

In this case, the support of *old* is the interval  $[50, 100]$ ; the height of *old* is effectively unity; and the crossover point of *old* is 55.

---

① More detailed discussions of fuzzy sets and their properties may be found in the listed references. (A detailed exposition of the fundamentals together with many illustrative examples may be found in the recent text by A. Kaufmann [20].)

② More generally, the range of  $\mu_A$  may be a partially or ordered set (see [21], [22]) or a collection of fuzzy sets. The latter case will be discussed in greater detail in Sec. 6.

To simplify the representation of fuzzy sets we shall employ the following notation.

A nonfuzzy finite set such as

$$U = \{u_1, \dots, u_n\} \quad (3.2)$$

will be expressed as

$$U = u_1 + u_2 + \dots + u_n \quad (3.3)$$

or

$$U = \sum_{i=1}^n u_i, \quad (3.4)$$

with the understanding that  $+$  denotes the union rather than the arithmetic sum. Thus, (3.3) may be viewed as a representation of  $U$  as the union of its constituent singletons.

As an extension of (3.3), a fuzzy subset  $A$  of  $U$  will be expressed as

$$A = \mu_1 u_1 + \dots + \mu_n u_n \quad (3.5)$$

or

$$A = \sum_{i=1}^n \mu_i \mu_i, \quad (3.6)$$

where  $\mu_i, i = 1, \dots, n$ , is the grade of membership of  $\mu_i$  in  $A$ . In cases where the  $u_i$  are numbers, there might be some ambiguity regarding the identity of the  $\mu_i$  and  $u_i$  components of the string  $\mu_i u_i$ . In such cases, we shall employ a separator symbol such as  $/$  for disambiguation, writing

$$A = \mu_1 / u_1 + \dots + \mu_n / u_n \quad (3.7)$$

or

$$A = \sum_{i=1}^n \mu_i / u_i. \quad (3.8)$$

*Example 3.2.* Let  $U = \{a, b, c, d\}$  or, equivalently,

$$U = a + b + c + d. \quad (3.9)$$

In this case, a fuzzy subset  $A$  of  $U$  may be represented unambiguously as

$$A = 0.3a + b + 0.9c + 0.5d. \quad (3.10)$$

On the other hand, if

$$U = 1 + 2 + \dots + 100, \quad (3.11)$$

then we shall write

$$A = 0.3/25 + 0.9/3 \quad (3.12)$$

in order to avoid ambiguity.

*Example 3.3.* In the universe of discourse comprising the integers  $1, 2, \dots, 10$ , i. e. ,

$$U = 1 + 2 + \dots + 10, \quad (3.13)$$

the fuzzy subset labeled *several* may be defined as

$$\text{several} = 0.5/3 + 0.8/4 + 1/5 + 1/6 + 0.8/7 + 0.5/8. \quad (3.14)$$

*Example 3.4.* In the case of the countable universe of discourse

$$U = 0 + 1 + 2 + \dots, \quad (3.15)$$

the fuzzy set labeled *small* may be expressed as

$$\text{small} = \sum_0^{\infty} \left[ 1 + \left( \frac{u}{10} \right)^2 \right]^{-1} / u. \quad (3.16)$$

Like (3.3), (3.5) may be interpreted as a representation of a fuzzy set as the union of its constituent fuzzy singletons  $\mu_i u_i$  (or  $\mu_i / u_i$ ). From the definition of the union [see (3.34)], it follows that if in the representation of  $A$  we have  $u_i = u_j$ , then we can make the substitution expressed by

$$\mu_i u_i + \mu_j u_i = (\mu_i \vee \mu_j) u_i. \quad (3.17)$$

For example,

$$A = 0.3a + 0.8a + 0.5b \quad (3.18)$$

may be rewritten as

$$\begin{aligned} A &= (0.3 \vee 0.8)a + 0.5b \\ &= 0.8a + 0.5b. \end{aligned} \quad (3.19)$$

When the support of a fuzzy set is a continuum rather than a countable or a finite set, we shall write

$$A = \int_U \mu_A(u)/u, \quad (3.20)$$

with the understanding that  $\mu_A(u)$  is the grade of membership of  $u$  in  $A$ , and the integral denotes the union of the fuzzy singletons  $\mu_A(u)/u, u \in U$ .

*Example 3.5.* In the universe of discourse consisting of the interval  $[0, 100]$ , with  $u = \text{age}$ , the fuzzy subset labeled *old* [whose membership function is given by (3.1)] may be expressed as

$$\text{old} = \int_{50}^{100} \left[ 1 + \left( \frac{u-50}{5} \right)^{-2} \right]^{-1} / u. \quad (3.21)$$

Note that the crossover point for this set, that is, the point  $u$  at which

$$\mu_{\text{old}}(u) = 0.5, \quad (3.22)$$

is  $u = 55$ .

A fuzzy set  $A$  is said to be *normal* if its height is unity, that is, if

$$\text{Sup}_u \mu_A(u) = 1. \quad (3.23)$$

Otherwise  $A$  is *subnormal*. In this sense, the set *old* defined by (3.21) is *normal*, as is the set *several* defined by (3.14). On the other hand, the subset of  $U = 1 + 2 + \dots + 10$  labeled *not small and not large* and defined by

$$\text{not small and not large} = 0.2/2 + 0.3/3 + 0.4/4 + 0.5/5$$



$$+0.4/6+0.3/7+0.2/8 \quad (3.24)$$

is subnormal. It should be noted that a subnormal fuzzy set may be *normalized* by dividing  $\mu_A$  by  $\text{Sup}_u \mu_A(u)$ .

A fuzzy subset of  $U$  may be a subset of another fuzzy or nonfuzzy subset of  $U$ . More specifically,  $A$  is a *subset of*  $B$  or is *contained in*  $B$  iff  $\mu_A(u) \leq \mu_B(u)$  for all  $u$  in  $U$ . In symbols,

$$A \subset B \Leftrightarrow \mu_A(u) \leq \mu_B(u), \quad u \in U. \quad (3.25)$$

*Example 3.6.* If  $U = a + b + c + d$  and

$$\begin{aligned} A &= 0.5a + 0.8b + 0.3d, \\ B &= 0.7a + b + 0.3c + d, \end{aligned} \quad (3.26)$$

then  $A \subset B$ .

#### *Level-sets of a fuzzy set*

If  $A$  is a fuzzy subset of  $U$ , then an  $\alpha$ -*level set* of  $A$  is a nonfuzzy set denoted by  $A_\alpha$  which comprises all elements of  $U$  whose grade of membership in  $A$  is greater than or equal to  $\alpha$ . In symbols,

$$A_\alpha = \{u \mid \mu_A(u) \geq \alpha\}. \quad (3.27)$$

A fuzzy set  $A$  may be decomposed into its level-sets through the *resolution identity*<sup>①</sup>

$$A = \int_0^1 \alpha A_\alpha \quad (3.28)$$

or

$$A = \sum_\alpha \alpha A_\alpha \quad (3.29)$$

where  $\alpha A_\alpha$  is the product of a scalar  $\alpha$  with the set  $A_\alpha$  [in the sense

---

① The resolution identity and some of its applications are discussed in greater detail in [6] and [24].

of (3.39)], and  $\int_0^1$  (or  $\Sigma_\alpha$ ) is the union of the  $A_\alpha$  with  $\alpha$  ranging from 0 to 1.

The resolution identity may be viewed as the result of combining together those terms in (3.5) which fall into the same level-set. More specifically, suppose that  $A$  is represented in the form

$$A = 0.1/2 + 0.3/1 + 0.5/7 + 0.9/6 + 1/9. \quad (3.30)$$

Then by using (3.17),  $A$  can be rewritten as

$$\begin{aligned} A = & 0.1/2 + 0.1/1 + 0.1/7 + 0.1/6 + 0.1/9 \\ & + 0.3/1 + 0.3/7 + 0.3/6 + 0.3/9 \\ & + 0.5/7 + 0.5/6 + 0.5/9 \\ & + 0.9/6 + 0.9/9 \\ & + 1/9 \end{aligned}$$

or

$$\begin{aligned} A = & 0.1(1/2 + 1/1 + 1/7 + 1/6 + 1/9) \\ & + 0.3(1/1 + 1/7 + 1/6 + 1/9) \\ & + 0.5(1/7 + 1/6 + 1/9) \\ & + 0.9(1/6 + 1/9) \\ & + 1(1/9), \end{aligned} \quad (3.31)$$

which is in the form (3.29), with the level-sets given by [see (3.27)]

$$\begin{aligned} A_{0.1} &= 2 + 1 + 7 + 6 + 9, \\ A_{0.3} &= 1 + 7 + 6 + 9, \\ A_{0.5} &= 7 + 6 + 9, \\ A_{0.9} &= 6 + 9, \\ A_1 &= 9. \end{aligned} \quad (3.32)$$

As will be seen in later sections, the resolution identity—in combination with the extension principle—provides a convenient way of generalizing various concepts associated with nonfuzzy sets to fuzzy sets. This, in fact, is the underlying basis for many of the definitions stated in what follows.

*Operations on fuzzy sets*

Among the basic operations which can be performed on fuzzy sets are the following.

1. The *complement* of  $A$  is denoted by  $\neg A$  (or sometimes by  $A'$ ) and is defined by

$$\neg A = \int_U [1 - \mu_A(u)]/u. \quad (3.33)$$

The operation of complementation corresponds to negation. Thus, if  $A$  is a label for a fuzzy set, then *not*  $A$  would be interpreted as  $\neg A$ . (See Example 3.7 below.)

2. The *union* of fuzzy sets  $A$  and  $B$  is denoted by  $A+B$  (or, more conventionally, by  $A \cup B$ ) and is defined by

$$A+B = \int_U [\mu_A(u) \vee \mu_B(u)]/u. \quad (3.34)$$

The union corresponds to the connective *or*. Thus, if  $A$  and  $B$  are labels of fuzzy sets, then *A or B* would be interpreted as  $A+B$ .

3. The *intersection* of  $A$  and  $B$  is denoted by  $A \cap B$  and is defined by

$$A \cap B = \int_U [\mu_A(u) \wedge \mu_B(u)]/u. \quad (3.35)$$

The intersection corresponds to the connective *and*; thus

$$A \text{ and } B = A \cap B. \quad (3.36)$$

Comment 3.1. It should be understood that  $\vee (\underline{\Delta} \text{Max})$  and  $\wedge (\underline{\Delta} \text{Min})$  are not the only operations in terms of which the union and intersection can be defined. (See [25] and [26] for discussions of this point.) In this connection, it is important to note that when *and* is identified with Min, as in (3.36), it represents a "hard" *and* in the sense that it allows no trade-offs between its operands. By contrast, an *and* identified with the arithmetic product, as in (3.37) below, would act as a "soft" *and*. Which of these two and possibly other definitions is more appropriate depends on the context in which *and* is used.

4. The *product* of  $A$  and  $B$  is denoted by  $AB$  and is defined by

$$AB = \int_U \mu_A(u) \mu_B(u) / u. \quad (3.37)$$

Thus,  $A^\alpha$ , where  $\alpha$  is any positive number, should be interpreted as

$$A^\alpha = \int_U [\mu_A(u)]^\alpha / u. \quad (3.38)$$

Similarly, if  $\alpha$  is any nonnegative real number such that  $\alpha \text{Sup}_u \mu_A(u) \leq 1$ , then

$$\alpha A = \int_U \alpha \mu_A(u) / u. \quad (3.39)$$

As a special case of (3.38), the operation of *concentration* is defined as

$$\text{CON}(A) = A^2, \quad (3.40)$$

while that of *dilation* is expressed by

$$\text{DIL}(A) = A^{0.5} \quad (3.41)$$

As will be seen in Part II, Sec. 3, the operations of

concentration and dilation are useful in the representation of linguistic hedges.

*Example 3.7.* If

$$\begin{aligned} U &= 1 + 2 + \dots + 10, \\ A &= 0.8/3 + 1/5 + 0.6/6, \\ B &= 0.7/3 + 1/4 + 0.5/6, \end{aligned} \quad (3.42)$$

then

$$\begin{aligned} \neg A &= 1/1 + 1/2 + 0.2/3 + 1/4 + 0.4/6 + 1/7 + 1/8 + 1/9 + 1/10, \\ A + B &= 0.8/3 + 1/4 + 1/5 + 0.6/6, \\ A \cap B &= 0.7/3 + 0.5/6, \\ AB &= 0.56/3 + 0.3/6, \\ A^2 &= 0.64/3 + 1/5 + 0.36/6, \\ 0.4A &= 0.32/3 + 0.4/5 + 0.24/6, \\ \text{CON}(B) &= 0.49/3 + 1/4 + 0.25/6, \\ \text{DIL}(B) &= 0.84/3 + 1/4 + 0.7/6. \end{aligned} \quad (3.43)$$

5. If  $A_1, \dots, A_n$  are fuzzy subsets of  $U$ , and  $w_1, \dots, w_n$  are nonnegative weights adding up to unity, then a *convex combination* of  $A_1, \dots, A_n$  is a fuzzy set  $A$  whose membership function is expressed by

$$\mu_A = w_1 \mu_{A_1} + \dots + w_n \mu_{A_n}, \quad (3.44)$$

where  $+$  denotes the arithmetic sum. The concept of a convex combination is useful in the representation of linguistic hedges such as *essentially*, *typically*, etc., which modify the weights associated with the components of fuzzy set [27].

6. If  $A_1, \dots, A_n$  are fuzzy subsets of  $U_1, \dots, U_n$ , respectively, the *Cartesian product* of  $A_1, \dots, A_n$  is denoted by  $A_1 \times \dots \times A_n$  and is defined as a fuzzy subset of  $U_1 \times \dots \times U_n$  whose membership function is expressed by

$$\mu_{A_1 \times \dots \times A_n}(u_1, \dots, u_n) = \mu_{A_1}(u_1) \wedge \dots \wedge \mu_{A_n}(u_n). \quad (3.45)$$

Thus, we can write [see (3.52)]

$$A_1 \times \dots \times A_n = \int_{U_1 \times \dots \times U_n} [\mu_{A_1}(u_1) \wedge \dots \wedge \mu_{A_n}(u_n)] / (u_1, \dots, u_n). \quad (3.46)$$

*Example 3.8.* If  $U_1 = U_2 = 3 + 5 + 7$ ,  $A_1 = 0.5/3 + 1/5 + 0.6/7$  and  $A_2 = 1/3 + 0.6/5$ , then

$$\begin{aligned} A_1 \times A_2 = & 0.5/(3,3) + 1/(5,3) + 0.6/(7,3) \\ & + 0.5/(3,5) + 0.6/(5,5) + 0.6/(7,5). \end{aligned} \quad (3.47)$$

7. The operation of *fuzzification* has, in general, the effect of transforming a nonfuzzy set into a fuzzy set or increasing the fuzziness of a fuzzy set. Thus, a *fuzzifier*  $F$  applied to a fuzzy subset  $A$  of  $U$  yields a fuzzy subset  $F(A;K)$  which is expressed by

$$F(A;K) = \int_U \mu_A(u)K(u), \quad (3.48)$$

where the fuzzy set  $K(u)$  is the *kernel* of  $F$ , that is, the result of applying  $F$  to a singleton  $1/u$ :

$$K(u) = F(1/u;K); \quad (3.49)$$

$\mu_A(u)K(u)$  represents the product [in the sense of (3.39) of a scalar  $\mu_A(u)$  and the fuzzy set  $K(u)$ ; and  $\int$  is the union of the family of fuzzy sets  $\mu_A(u)K(u)$ ,  $u \in U$ . In effect, (3.48) is analogous to the integral representation of a linear operator, with  $K(u)$  being the counterpart of the impulse response.

*Example 3.9.* Assume that  $U, A$  and  $K(u)$  are defined by

$$\begin{aligned}
 U &= 1+2+3+4, \\
 A &= 0.8/1+0.6/2, \\
 K(1) &= 1/1+0.4/2, \\
 K(2) &= 1/2+0.4/1+0.4/3.
 \end{aligned}
 \tag{3.50}$$

Then

$$\begin{aligned}
 F(A;K) &= 0.8(1/1+0.4/2)+0.6(1/2+0.4/1+0.4/3) \\
 &= 0.8/1+0.6/2+0.24/3.
 \end{aligned}
 \tag{3.51}$$

The operation of fuzzification plays an important role in the definition of linguistic hedges such as *more or less*, *slightly*, *somewhat*, *much*, etc. For example, if  $A \triangleq$  positive is the label for the nonfuzzy class of positive numbers, then *slightly positive* is a label for a fuzzy subset of the real line whose membership function is of the form shown in Fig. 11. In this case, *slightly* is a fuzzifier which transforms *positive* into *slightly positive*. However, it is not always possible to express the effect of a fuzzifier in the form (3.48), and *slightly* is a case in point. A more detailed discussion of this and related issues may be found in [27].

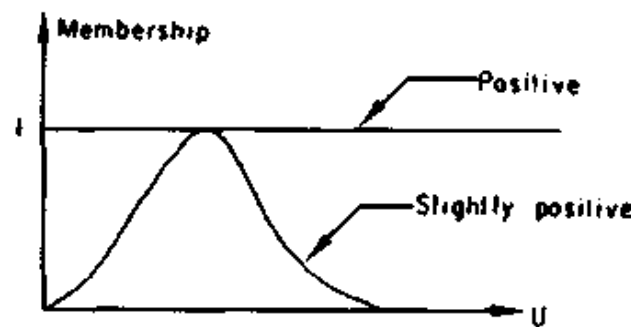

Fig. 11. Membership functions of *positive* and *slightly positive*.

### Fuzzy relations

If  $U$  is the Cartesian product of  $n$  universes of discourse  $U_1, \dots, U_n$ , then an  $n$ -ary fuzzy relation,  $R$ , in  $U$  is a fuzzy subset of

$U$ . As in (3.20),  $R$  may be expressed as the union of its constituent fuzzy singletons  $\mu_R(u_1, \dots, u_n)/(u_1, \dots, u_n)$ , i. e. ,

$$R = \int_{U_1 \times \dots \times U_n} \mu_R(u_1, \dots, u_n)/(u_1, \dots, u_n), \quad (3.52)$$

where  $\mu_R$  is the membership function of  $R$ .

Common examples of (binary) fuzzy relations are; *much greater than*, *resembles*, *is relevant to*, *is close to*, etc. For example, if  $U_1 = U_2 = (-\infty, \infty)$ , the relation *is close to* may be defined by

$$\textit{is close to} \triangleq \int_{U_1 \times U_2} e^{-a|u_1 - u_2|}/(u_1, u_2), \quad (3.53)$$

where  $a$  is a scale factor. Similarly, if  $U_1 = U_2 = 1 + 2 + 3 + 4$ , then the relation *much greater than* may be defined by the relation matrix

$R$	1	2	3	4	(3.54)
1	0	0.3	0.8	1	
2	0	0	0	0.8	
3	0	0	0	0.3	
4	0	0	0	0	

in which the  $(i, j)$ th element is the value of  $\mu_R(u_1, u_2)$  for the  $i$ th value of  $u_1$  and  $j$ th value of  $u_2$ .

If  $R$  is a relation from  $U$  to  $V$  (or, equivalently, a relation in  $U \times V$ ) and  $S$  is a relation from  $V$  to  $W$ , then the composition of  $R$  and  $S$  is a fuzzy relation from  $U$  to  $W$  denoted by  $R \circ S$  and defined by<sup>①</sup>

---

① Equation (3.55) defines the max-min composition of  $R$  and  $S$ . Max-product composition is defined similarly, except that  $\wedge$  is replaced by the arithmetic product. A more detailed discussion of these compositions may be found in [24].



$$R \circ S = \int_{U \times W} \bigvee_v [\mu_R(u, v) \wedge \mu_S(v, w)] / (u, w). \quad (3.55)$$

If  $U, V$  and  $W$  are finite sets, then the relation matrix for  $R \circ S$  is the max-min product<sup>①</sup> of the relation matrices for  $R$  and  $S$ . For example, the max-min product of the relation matrices on the left-hand side of (3.56) is given by the right-hand side of (3.56):

$$\begin{array}{ccc} R & S & R \circ S \\ \begin{bmatrix} 0.3 & 0.8 \\ 0.6 & 0.9 \end{bmatrix} & \circ \begin{bmatrix} 0.5 & 0.9 \\ 0.4 & 1 \end{bmatrix} & = \begin{bmatrix} 0.4 & 0.8 \\ 0.5 & 0.9 \end{bmatrix} \end{array} \quad (3.56)$$

#### Projections and cylindrical fuzzy sets

If  $R$  is an  $n$ -ary fuzzy relation in  $U_1 \times \cdots \times U_n$ , then its *projection (shadow)* on  $U_{i_1} \times \cdots \times U_{i_k}$  is a  $k$ -ary fuzzy relation  $R_q$  in  $U$  which is defined by [compare with (2.12)]

$$\begin{aligned} R_q &\triangleq \text{Proj } R \text{ on } U_{i_1} \times \cdots \times U_{i_k} \\ &\triangleq P_q R \\ &\triangleq \int_{U_{i_1} \times \cdots \times U_{i_k}} [\bigvee_{u(q)} \mu_R(u_1, \dots, u_n)] / (u_{i_1}, \dots, u_{i_k}), \end{aligned} \quad (3.57)$$

where  $q$  is the index sequence  $(i_1, \dots, i_k)$ ;  $u(q) \triangleq (u_{i_1}, \dots, u_{i_k})$ ;  $q'$  is the complement of  $q$ ; and  $\bigvee_{u(q)}$  is the supremum of  $\mu_R(u_1, \dots, u_n)$  over the  $u$ 's which are in  $u(q)$ . It should be noted that when  $R$  is a nonfuzzy relation, (3.57) reduces to (2.9).

*Example 3.10.* For the fuzzy relation defined by the relation matrix (3.54), we have

$$R_1 = 1/1 + 0.8/2 + 0.3/3$$

① In the max-min matrix product, the operations of addition and multiplication are replaced by  $\bigvee$  and  $\wedge$ , respectively.

and

$$R_2 = 0.3/2 + 0.8/3 + 1/4.$$

It is clear that distinct fuzzy relations in  $U_1 \times \dots \times U_n$  can have identical projections on  $U_{i_1} \times \dots \times U_{i_k}$ . However, given a fuzzy relation  $R_q$  in  $U_{i_1} \times \dots \times U_{i_k}$ , there exists a unique largest<sup>①</sup> relation  $\bar{R}_q$  in  $U_1 \times \dots \times U_n$  whose projection on  $U_{i_1} \times \dots \times U_{i_k}$  is  $R_q$ . In consequence of (3.57), the membership function of  $\bar{R}_q$  is given by

$$\mu_{\bar{R}_q}(u_1, \dots, u_n) = \mu_{R_q}(u_{i_1}, \dots, u_{i_k}), \quad (3.58)$$

with the understanding that (3.58) holds for all  $u_1, \dots, u_n$  such that the  $i_1, \dots, i_k$  arguments in  $\mu_{\bar{R}_q}$  are equal, respectively, to the first, second,  $\dots, k$ th arguments in  $\mu_{R_q}$ . This implies that the value of  $\mu_{\bar{R}_q}$  at the point  $(u_1, \dots, u_n)$  is the same as that at the point  $(u'_{i_1}, \dots, u'_{i_k})$  provided that  $u_{i_1} = u'_{i_1}, \dots, u_{i_k} = u'_{i_k}$ . For this reason,  $\bar{R}_q$  will be referred to as the *cylindrical extension* of  $R_q$ , with  $R_q$  constituting the *base* of  $\bar{R}_q$ . (See Fig. 12.)

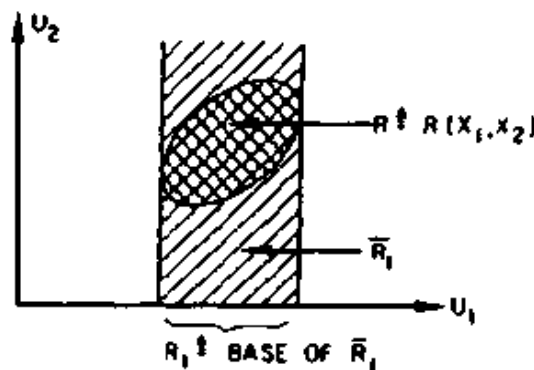

Fig. 12.  $R_1$  is the base of the cylindrical set  $\bar{R}_1$ .

① That is, a relation which contains all other relations whose projection on  $U_{i_1} \times \dots \times U_{i_k}$  is  $R_q$ .

Suppose that  $R$  is an  $n$ -ary relation in  $U_1 \times \cdots \times U_n$ ,  $R_q$  is its projection on  $U_{i_1} \times \cdots \times U_{i_k}$ , and  $\bar{R}_q$  is the cylindrical extension of  $R_q$ . Since  $\bar{R}_q$  is the largest relation in  $U_1 \times \cdots \times U_n$  whose projection on  $U_{i_1} \times \cdots \times U_{i_k}$  is  $R_q$ , it follows that  $R_q$  satisfies the *containment relation*

$$R \subset \bar{R}_q \quad (3.59)$$

for all  $q$ , and hence

$$R \subset \bar{R}_{q_1} \cap \bar{R}_{q_2} \cap \cdots \cap \bar{R}_{q_r} \quad (3.60)$$

for arbitrary  $q_1, \dots, q_r$  [index subsequences of  $(1, 2, \dots, n)$ ].

In particular, if we set  $q_1 = 1, \dots, q_r = n$ , then (3.60) reduces to

$$R \subset \bar{R}_1 \cap \bar{R}_2 \cap \cdots \cap \bar{R}_n, \quad (3.61)$$

where  $R_1, \dots, R_n$  are the projections of  $R$  on  $U_1, \dots, U_n$ , respectively, and  $\bar{R}_1, \dots, \bar{R}_n$  are their cylindrical extensions. But, from the definition of the Cartesian product [see (3.45)] it follows that

$$\bar{R}_1 \cap \cdots \cap \bar{R}_n = R_1 \times \cdots \times R_n, \quad (3.62)$$

which leads us to the

**Proposition 3.1.** *If  $R$  is an  $n$ -ary fuzzy relation in  $U_1 \times \cdots \times U_n$  and  $R_1, \dots, R_n$  are its projections on  $U_1, \dots, U_n$ , then (see Fig. 13 for illustration)*

$$R \subset R_1 \times \cdots \times R_n. \quad (3.63)$$

The concept of a cylindrical extension can also be used to provide an intuitively appealing interpretation of the composition of fuzzy relations. Thus, suppose that  $R$  and  $S$  are binary fuzzy relations in  $U_1 \times U_2$  and  $U_2 \times U_3$ , respectively. Let  $\bar{R}$  and  $\bar{S}$  be the cylindrical extensions of  $R$  and  $S$  in  $U_1 \times U_2 \times U_3$ . Then, from the

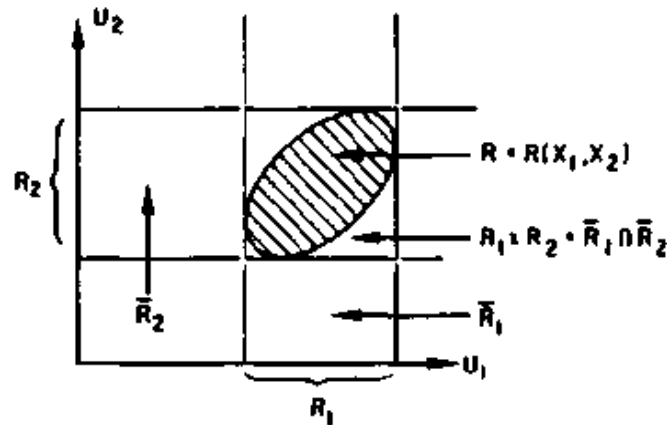

Fig. 13. Relation between the Cartesian product and intersection of cylindrical sets.

definition of  $R \circ S$  [see (3.55)] it follows that

$$R \circ S = \text{Proj } \bar{R} \cap \bar{S} \text{ on } U_1 \times U_3. \quad (3.64)$$

If  $R$  and  $S$  are such that

$$\text{Proj } R \text{ on } U_2 = \text{Proj } S \text{ on } U_2, \quad (3.65)$$

then  $\bar{R} \cap \bar{S}$  becomes the *join*<sup>①</sup> of  $R$  and  $S$ . A basic property of the join of  $R$  and  $S$  may be stated as

**Proposition 3.2.** *If  $R$  and  $S$  are fuzzy relations in  $U_1 \times U_2$  and  $U_2 \times U_3$ , respectively, and  $\bar{R} \cap \bar{S}$  is the join of  $R$  and  $S$ , then*

$$R = \text{Proj } \bar{R} \cap \bar{S} \text{ on } U_1 \times U_2 \quad (3.66)$$

and

$$S = \text{Proj } \bar{R} \cap \bar{S} \text{ on } U_2 \times U_3. \quad (3.67)$$

Thus,  $R$  and  $S$  can be retrieved from the join of  $R$  and  $S$ .

*Proof.* Let  $\mu_R$  and  $\mu_S$  denote the membership functions of  $R$  and  $S$ , respectively. Then the right-hand sides of (3.66) and (3.67) translate into

<sup>①</sup> The concept of the join of nonfuzzy relations was introduced by E. F. Codd in [28].

$$V_{u_3}[\mu_R(u_1, u_2) \wedge \mu_S(u_2, u_3)] \quad (3.68)$$

and

$$V_{u_1}[\mu_R(u_1, u_2) \wedge \mu_S(u_2, u_3)]. \quad (3.69)$$

In virtue of the distributivity and commutativity of  $V$  and  $\wedge$ , (3.68) and (3.69) may be rewritten as

$$\mu_R(u_1, u_2) \wedge [V_{u_3}\mu_S(u_2, u_3)] \quad (3.70)$$

and

$$\mu_S(u_2, u_3) \wedge [V_{u_1}\mu_R(u_1, u_2)]. \quad (3.71)$$

Furthermore, the definition of the join implies (3.65) and hence that

$$V_{u_1}\mu_R(u_1, u_2) = V_{u_3}\mu_S(u_2, u_3). \quad (3.72)$$

From this equality and the definition of  $V$  it follows that

$$\mu_R(u_1, u_2) \leq V_{u_1}\mu_R(u_1, u_2) = V_{u_3}\mu_S(u_2, u_3) \quad (3.73)$$

and

$$\mu_S(u_2, u_3) \leq V_{u_3}\mu_S(u_2, u_3) = V_{u_1}\mu_R(u_1, u_2). \quad (3.74)$$

Consequently

$$\mu_R(u_1, u_2) \wedge [V_{u_3}\mu_S(u_2, u_3)] = \mu_R(u_1, u_2) \quad (3.75)$$

and

$$\mu_S(u_2, u_3) \wedge [V_{u_1}\mu_R(u_1, u_2)] = \mu_S(u_2, u_3), \quad (3.76)$$

which translate into (3.66) and (3.67). Q. E. D.

A basic property of projections which we shall have an occasion to use in Part I, Sec. 1 is the following.

**Proposition 3.3.** *If  $R$  is a normal relation [see (3.23)], then so is every projection of  $R$ .*

*Proof.* Let  $R$  be an  $n$ -ary relation in  $U_1 \times \cdots \times U_n$ , and let  $R_q$  be its projection (shadow) on  $U_{i_1} \times \cdots \times U_{i_k}$ , with  $q = (i_1, \dots, i_k)$ .

Since  $R$  is normal, we have by (3.23),

$$\bigvee_{(u_1, \dots, u_n)} \mu_R(u_1, \dots, u_n) = 1, \quad (3.77)$$

or more compactly

$$\bigvee_u \mu_R(u) = 1.$$

On the other hand, by the definition of  $R_q$  [see (3.57)],

$$\mu_{R_q}(u_{i_1}, \dots, u_{i_k}) = \bigvee_{(u_{j_1}, \dots, u_{j_m})} \mu_R(u_1, \dots, u_n),$$

or

$$\mu_{R_q}(u_{(q)}) = \bigvee_{u_{(q)}} \mu_R(u),$$

and hence the height of  $R_q$  is given by

$$\begin{aligned} \bigvee_{u_{(q)}} \mu_{R_q}(u_{(q)}) &= \bigvee_{u_{(q)}} \bigvee_{u_{(q)}} \mu_R(u) & (3.78) \\ &= \bigvee_u \mu_R(u) \\ &= 1. \quad \text{Q. E. D.} \end{aligned}$$

### *The extension principle*

The *extension principle* for fuzzy sets is in essence a basic identity which allows the domain of the definition of a mapping or a relation to be extended from points in  $U$  to fuzzy subsets of  $U$ . More specifically, suppose that  $f$  is a mapping from  $U$  to  $V$ , and  $A$  is a fuzzy subset of  $U$  expressed as

$$A = \mu_1 u_1 + \dots + \mu_n u_n. \quad (3.79)$$

Then the extension principle asserts that <sup>①</sup>

$$f(A) = f(\mu_1 u_1 + \dots + \mu_n u_n) \equiv \mu_1 f(u_1) + \dots + \mu_n f(u_n). \quad (3.80)$$

---

① The extension principle is implicit in a result given in [29]. In probability theory, the extension principle is analogous to the expression for the probability distribution induced by a mapping [30]. In the special case of intervals, the results of applying the extension principle reduced to those of interval analysis [31].

Thus, the image of  $A$  under  $f$  can be deduced from the knowledge of the images of  $u_1, \dots, u_n$  under  $f$ .

*Example 3.11.* Let

$$U = 1 + 2 + \dots + 10,$$

and let  $f$  be the operation of squaring. Let *small* be a fuzzy subset of  $U$  defined by

$$\text{small} = 1/1 + 1/2 + 0.8/3 + 0.6/4 + 0.4/5. \quad (3.81)$$

Then, in consequence of (3.80), we have<sup>①</sup>

$$\text{small}^2 = 1/1 + 1/4 + 0.8/9 + 0.6/16 + 0.4/25. \quad (3.82)$$

If the support of  $A$  is a continuum, that is,

$$A = \int_U \mu_A(u)/u, \quad (3.83)$$

then the statement of the extension principle assumes the following form:

$$f(A) = f\left(\int_U \mu_A(u)/u\right) \equiv \int_V \mu_A(u)/f(u), \quad (3.84)$$

with the understanding that  $f(u)$  is a point in  $V$  and  $\mu_A(u)$  is its grade of membership in  $f(A)$ , which is a fuzzy subset of  $V$ .

In some applications it is convenient to use a modified form of the extension principle which follows from (3.84) by decomposing  $A$  into its constituent level-sets rather than its fuzzy singletons [see the resolution identity (3.28)]. Thus, on writing

$$A = \int_0^1 \alpha A_\alpha, \quad (3.85)$$

where  $A_\alpha$  is an  $\alpha$ -level set of  $A$ , the statement of the extension principle assumes the form

---

① Note that this definition of *small*<sup>2</sup> differs from that of (3.38).

$$f(A) = f\left(\int_0^1 \alpha A_\alpha\right) \equiv \int_0^1 \alpha f(A_\alpha) \quad (3.86)$$

when the support of  $A$  is a continuum, and

$$f(A) = f\left(\sum_\alpha \alpha A_\alpha\right) = \sum_\alpha \alpha f(A_\alpha) \quad (3.87)$$

when either the support of  $A$  is a countable set or the distinct level-sets of  $A$  form a countable collection.

Comment 3.2. Written in the form (3.84), the extension principle extends the domain of definition of  $f$  from points in  $U$  to fuzzy subsets of  $U$ . By contrast, (3.86) extends the domain of definition of  $f$  from nonfuzzy subsets of  $U$  to fuzzy subsets of  $U$ . It should be clear, however, that (3.84) and (3.86) are equivalent, since (3.86) results from (3.84) by a regrouping of terms in the representation of  $A$ .

Comment 3.3. The extension principle is analogous to the superposition principle for linear systems. Under the latter principle, if  $L$  is a linear system and  $u_1, \dots, u_n$  are inputs to  $L$ , then the response of  $L$  to any linear combination

$$u = w_1 u_1 + \dots + w_n u_n, \quad (3.88)$$

where the  $w_i$  are constant coefficients, is given by

$$L(u) = L(w_1 u_1 + \dots + w_n u_n) = w_1 L(u_1) + \dots + w_n L(u_n). \quad (3.89)$$

The important point of difference between (3.89) and (3.80) is that in (3.80)  $+$  is the union rather than the arithmetic sum, and  $f$  is not restricted to linear mappings.

Comment 3.4. It should be noted that when  $A = u_1 + \dots + u_n$ , the result of applying the extension principle is analogous to that of forming the  $n$ -fold Cartesian product of the algebraic



system  $(U, f)$  with itself. (An extension of the multiplication table is shown in Table 3.1.)

X	1	2	3	4	1v2	2v4
1	1	2	3	4	1v2	2v4
2	2	4	6	8	1v4	4v8
3	3	6	9	12	3v6	6v12
4	4	8	12	16	4v8	8v16
1v2	1v2	2v4	3v6	4v8	1v2v4	2v4v8

3 v 5 v 6

x  
2 v 4 v 6

---

6 v 10 v 12

12 v 20 v 24

18 v 30 v 36

---

6 v 10 v 12 v 18 v 20 v 24 v 30 v 36

Table 1. Extension of the multiplication table to subsets of integers. 1 V 2 means 1 or 2.

In many applications of the extension principle, one encounters the following problem. We have an  $n$ -ary function,  $f$ , which is a mapping from a Cartesian product  $U_1 \times \dots \times U_n$  to a space  $V$ , and a fuzzy set (relation)  $A$  in  $U_1 \times \dots \times U_n$  which is characterized by a membership function  $\mu_A(u_1, \dots, u_n)$ , with  $u_i, i = 1, \dots, n$ , denoting a generic point in  $U_i$ . A direct application of the extension principle (3.84) to this case yields

$$f(A) = f\left(\int_{u_1 \times \dots \times u_n} \mu_A(u_1, \dots, u_n) / (u_1, \dots, u_n)\right) \quad (3.90)$$

$$= \int_V \mu_A(u_1, \dots, u_n) / f(u_1, \dots, u_n).$$

However, in many instances what we know is not  $A$  but its projections  $A_1, \dots, A_n$  on  $U_1, \dots, U_n$ , respectively [see (3.57)]. The question that arises, then, is: What expression for  $\mu_A$  should be used in (3.90)?

In such cases, unless otherwise specified we shall assume that the membership function of  $A$  is expressed by

$$\mu_A(u_1, \dots, u_n) = \mu_{A_1}(u_1) \wedge \mu_{A_2}(u_2) \wedge \dots \wedge \mu_{A_n}(u_n), \quad (3.91)$$

where  $\mu_{A_i}, i=1, \dots, n$ , is the membership function of  $A_i$ . In view of (3.45), this is equivalent to assuming that  $A$  is the Cartesian product of its projections, i. e.,

$$A = A_1 \times \dots \times A_n,$$

which in turn implies that  $A$  is the largest set whose projections on  $U_1, \dots, U_n$  are  $A_1, \dots, A_n$ , respectively. [See (3.63).]

*Example 3.12.* Suppose that, as in Example 3.11,

$$U_1 = U_2 = 1 + 2 + 3 + \dots + 10$$

and

$$A_1 = \underline{2} \triangleq \text{approximately } 2 = 1/2 + 0.6/1 + 0.8/3, \quad (3.92)$$

$$A_2 = \underline{6} \triangleq \text{approximately } 6 = 1/6 + 0.8/5 + 0.7/7 \quad (3.93)$$

and

$$f(u_1, u_2) = u_1 \times u_2 = \text{arithmetic product of } u_1 \text{ and } u_2.$$

Using (3.91) and applying the extension principle as expressed by (3.90) to this case, we have

$$\begin{aligned} \underline{2} \times \underline{6} &= (1/2 + 0.6/1 + 0.8/3) \times (1/6 + 0.8/5 + 0.7/7) \\ &= 1/12 + 0.8/10 + 0.7/14 + 0.6/6 + 0.6/5 + 0.6/7 + \\ &\quad 0.8/18 + 0.8/15 + 0.7/21 \end{aligned}$$

$$= 0.6/5 + 0.6/6 + 0.6/7 + 0.8/10 + 1/12 + 0.7/14 + 0.8/15 + 0.8/18 + 0.7/21. \quad (3.94)$$

Thus, the arithmetic product of the fuzzy numbers *approximately 2* and *approximately 6* is a fuzzy number given by (3.94).

More generally, let  $*$  be a binary operation defined on  $U \times V$  with values in  $W$ . Thus, if  $u \in U$  and  $v \in V$ , then

$$w = u * v, w \in W$$

Now suppose that  $A$  and  $B$  are fuzzy subsets of  $U$  and  $V$ , respectively, with

$$\begin{aligned} A &= \mu_1 u_1 + \dots + \mu_n u_n, \\ B &= v_1 v_1 + \dots + v_m v_m. \end{aligned} \quad (3.95)$$

By using the extension principle under the assumption (3.91), the operation  $*$  may be extended to fuzzy subsets of  $U$  and  $V$  by the defining relation

$$\begin{aligned} A * B &= (\sum_i \mu_i u_i) * (\sum_j v_j v_j) \\ &= \sum_{(i,j)} (\mu_i \wedge v_j) (u_i * v_j). \end{aligned} \quad (3.96)$$

It is easy to verify that for the case where  $A = \underline{2}$ ,  $B = \underline{6}$  and  $*$  =  $\times$ , as in Example 3.12, the application of (3.96) yields the expression for  $\underline{2} \times \underline{6}$ .

Comment 3.5. It is important to note that the validity of (3.96) depends in an essential way on the assumption (3.91), that is,

$$\mu_{(A,B)}(u,v) = \mu_A(u) \wedge \mu_B(v).$$

The implication of this assumption is that  $u$  and  $v$  are noninteractive in the sense of Definition 2.2. Thus, if there is a constraint on  $(u,v)$  which is expressed as a relation  $R$  with a membership function  $\mu_R$ , then the expression for  $A * B$  becomes

$$\begin{aligned}
A * B &= \left[ \left( \sum_i \mu_i u_i \right) * \left( \sum_j v_j v_j \right) \right] \cap R \\
&= \sum_{ij} [\mu_i \wedge v_j \wedge \mu_R(u_i, v_j)] (u_i * v_j). \quad (3.97)
\end{aligned}$$

Note that if  $R$  is a nonfuzzy relation, then the right-hand side of (3.97) will contain only those terms which satisfy the constraint  $R$ .

A simple illustration of a situation in which  $u$  and  $v$  are interactive is provided by the expression

$$w = z \times (x + y), \quad (3.98)$$

in which  $+$   $\triangleq$  arithmetic sum and  $\times$   $\triangleq$  arithmetic product. If  $x, y$  and  $z$  are noninteractive, then we can apply the extension principle in the form (3.96) to the computation of  $A \times (B + C)$ , where  $A, B$  and  $C$  are fuzzy subsets of the real line. On the other hand, if (3.98) is rewritten as

$$w = z \times x + z \times y,$$

then the terms  $z \times x$  and  $z \times y$  are interactive by virtue of the common factor  $z$ , and hence

$$A \times (B + C) \neq A \times B + A \times C. \quad (3.99)$$

A significant conclusion that can be drawn from this observation is that the product of fuzzy numbers is not distributive if it is computed by the use of (3.96). To obtain equality in (3.99), we may apply the unrestricted form of the extension principle (3.96) to the left-hand side of (3.99), and must apply the restricted form (3.97) to its right-hand side.

**Remark 3.1.** The extension principle can be applied not only to functions, but also to relations or, equivalently, to predicates. We shall not discuss this subject here, since the application of the extension principle to relations does not play a

significant role in the present paper.

*Fuzzy sets with fuzzy membership functions*

Our consideration of fuzzy sets with fuzzy membership functions is motivated by the close association which exists between the concept of a linguistic truth with truth-values such as *true*, *quite true*, *very true*, *more or less true*, etc., on the one hand, and fuzzy sets in which the grades of membership are specified in linguistic terms such as *low*, *medium*, *high*, *very low*, *not low and not high*, etc., on the other.

Thus, suppose that  $A$  is a fuzzy subset of a universe of discourse  $U$ , and the values of the membership function,  $\mu_A$ , of  $A$  are allowed to be fuzzy subsets of the interval  $[0, 1]$ . To differentiate such fuzzy sets from those considered previously, we shall refer to them as fuzzy sets of *type 2*, with the fuzzy sets whose membership functions are mappings from  $U$  to  $[0, 1]$  classified as *type 1*. More generally;

Definition 3.1. A fuzzy set is of type  $n$ ,  $n = 2, 3, \dots$ , if its membership function ranges over fuzzy sets of type  $n-1$ . The membership function of a fuzzy set of type 1 ranges over the interval  $[0, 1]$ .

To define such operations as complementation, union, intersection, etc. for fuzzy sets of type 2, it is natural to make use of the extension principle. It is convenient, however, to accomplish this in two stages; first, by extending the type 1 definitions to fuzzy sets with interval-valued membership

functions; and second, generalizing from intervals to fuzzy sets <sup>(1)</sup> by the use of the levelset form of the extension principle [see (3.86)]. In what follows, we shall illustrate this technique by extending to fuzzy sets of type 2 the concept of intersection — which is defined for fuzzy sets of type 1 by (3.35).

Our point of departure is the expression for the membership function of the intersection of  $A$  and  $B$ , where  $A$  and  $B$  are fuzzy subsets of type 1 of  $U$ :

$$\mu_{A \cap B}(u) = \mu_A(u) \wedge \mu_B(u), \quad u \in U.$$

Now if  $\mu_A(u)$  and  $\mu_B(u)$  are intervals in  $[0, 1]$  rather than points in  $[0, 1]$  — that is, for a fixed  $u$ ,

$$\mu_A(u) = [a_1, a_2],$$

$$\mu_B(u) = [b_1, b_2],$$

where  $a_1, a_2, b_1$  and  $b_2$  depend on  $u$  — then the application of the extension principle (3.86) to the function  $\wedge$  (Min) yields

$$[a_1, a_2] \wedge [b_1, b_2] = [a_1 \wedge b_1, a_2 \wedge b_2]. \quad (3.100)$$

Thus, if  $A$  and  $B$  have interval-valued membership functions as shown in Fig. 14, then their intersection is an interval-valued curve whose value for each  $u$  is given by (3.100).

Next, let us consider the case where, for each  $u$ ,  $\mu_A(u)$  and  $\mu_B(u)$  are fuzzy subsets of the interval  $[0, 1]$ . For simplicity, we shall assume that these subsets are *convex*, that is, have intervals as level-sets. In other words, we shall assume that, for each  $\alpha$  in  $[0, 1]$ , the  $\alpha$ -level sets of  $\mu_A$  and  $\mu_B$  are interval-valued

---

(1) We are tacitly assuming that the fuzzy sets in question are convex, that is, have intervals as level-sets (see [29]). Only minor modifications are needed when the sets are not convex.

membership functions. (See Fig. 15).

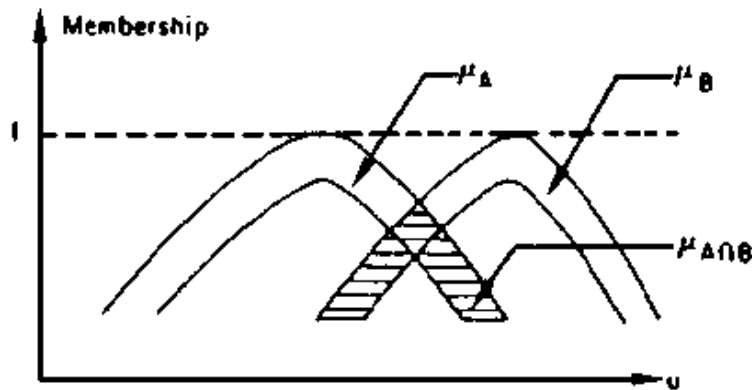

Fig. 14. Intersection of fuzzy sets with interval-valued membership functions.

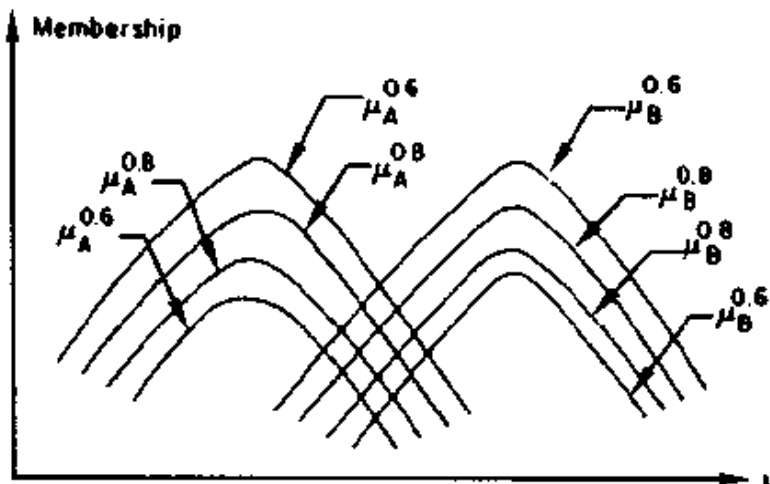

Fig. 15. Level-sets of fuzzy membership functions  $\mu_A$  and  $\mu_B$ .

By applying the level-set form of the extension principle (3.86) to the  $\alpha$ -level sets of  $\mu_A$  and  $\mu_B$  we are led to the following definition of the intersection of fuzzy sets of type 2.

**Definition 3.2.** Let  $A$  and  $B$  be fuzzy subsets of type 2 of  $U$  such that, for each  $u \in U$ ,  $\mu_A(u)$  and  $\mu_B(u)$  are convex fuzzy subsets of type 1 of  $[0,1]$ , which implies that, for each  $\alpha$  in  $[0,$

1], the  $\alpha$ -level sets of the fuzzy membership functions  $\mu_A$  and  $\mu_B$  are interval-valued membership functions  $\mu_A^\alpha$  and  $\mu_B^\alpha$ .

Let the  $\alpha$ -level set of the fuzzy membership function of the intersection of  $A$  and  $B$  be denoted by  $\mu_{A \cap B}^\alpha$ , with the  $\alpha$ -level sets  $\mu_A^\alpha$  and  $\mu_B^\alpha$  defined for each  $u$  by

$$\mu_A^\alpha \triangleq \{v/v_A(v) \geq \alpha\}, \quad (3.101)$$

$$\mu_B^\alpha \triangleq \{v/v_B(v) \geq \alpha\}, \quad (3.102)$$

where  $v_A(v)$  denotes the grade of membership of a point  $v, v \in [0, 1]$ , in the fuzzy set  $\mu_A(u)$ , and likewise for  $\mu_B$ . Then, for each  $u$ ,

$$\mu_{A \cap B}^\alpha = \mu_A^\alpha \wedge \mu_B^\alpha \quad (3.103)$$

In other words, the  $\alpha$ -level set of the fuzzy membership function of the intersection of  $A$  and  $B$  is the minimum [in the sense of (3.100)] of the  $\alpha$ -level sets of the fuzzy membership functions of  $A$  and  $B$ . Thus, using the resolution identity (3.28), we can express  $\mu_{A \cap B}$  as

$$\mu_{A \cap B} = \int_0^1 \alpha (\mu_A^\alpha \wedge \mu_B^\alpha). \quad (3.104)$$

For the case where  $\mu_A$  and  $\mu_B$  have finite supports, that is,  $\mu_A$  and  $\mu_B$  are of the form

$$\mu_A = \alpha_1 v_1 + \dots + \alpha_n v_n, v_i \in [0, 1], i = 1, \dots, n \quad (3.105)$$

and

$$\mu_B = \beta_1 w_1 + \dots + \beta_m w_m, w_j \in [0, 1], j = 1, \dots, m, \quad (3.106)$$

where  $\alpha_i$  and  $\beta_j$  are the grades of membership of  $v_i$  and  $w_j$  in  $\mu_A$  and  $\mu_B$ , respectively, the expression for  $\mu_{A \cap B}$  can readily be derived by employing the extension principle in the form (3.96).

Thus, by applying (3.96) to the operation  $\wedge$  ( $\triangleq$  Min), we obtain



at once

$$\begin{aligned}\mu_{A \cap B} &= \mu_A \wedge \mu_B & (3.107) \\ &= (\alpha_1 v_1 + \dots + \alpha_n v_n) \wedge (\beta_1 w_1 + \dots + \beta_m w_m) \\ &= \sum_{i,j} (\alpha_i \wedge \beta_j) (v_i \wedge w_j)\end{aligned}$$

as the desired expression for  $\mu_{A \cap B}$ . <sup>①</sup>

*Example 3.13.* As a simple illustration of (3.104), suppose that at a point  $u$  the grades of membership of  $u$  in  $A$  and  $B$  are labeled as *high* and *medium*, respectively, with *high* and *medium* defined as fuzzy subsets of  $V = 0 + 0.1 + 0.2 + \dots + 1$  by the expressions

$$\text{high} = 0.8/0.8 + 0.8/0.9 + 1/1, \quad (3.108)$$

$$\text{medium} = 0.6/0.4 + 1/0.5 + 0.6/0.6. \quad (3.109)$$

The level sets of *high* and *medium* are expressed by

$$\text{high}_{0.8} = 0.8 + 0.9 + 1,$$

$$\text{high}_{0.8} = 0.8 + 0.9 + 1,$$

$$\text{high}_1 = 1,$$

$$\text{medium}_{0.6} = 0.4 + 0.5 + 0.6,$$

$$\text{medium}_1 = 0.5,$$

and consequently the  $\alpha$ -level sets of the intersection are given by

$$\begin{aligned}\mu_{A \cap B}^{0.5}(u) &= \text{high}_{0.8} \wedge \text{medium}_{0.6} \\ &= (0.8 + 0.9 + 1) \wedge (0.4 + 0.5 + 0.6) \\ &= 0.4 + 0.5 + 0.6, & (3.110)\end{aligned}$$

$$\begin{aligned}\mu_{A \cap B}^{0.8}(u) &= \text{high}_{0.8} \wedge \text{medium}_{0.8} \\ &= (0.8 + 0.9 + 1) \wedge 0.5 \\ &= 0.5 & (3.111)\end{aligned}$$

---

① Actually, Definition 3.2 can be deduced from (3.90).

and

$$\begin{aligned}\mu_{A \cap B}^1(u) &= high_1 \wedge medium_1 \\ &= 1 \wedge 0.5 \\ &= 0.5\end{aligned}\quad (3.112)$$

Combining (3.110), (3.111) and (3.112), the fuzzy set representing the grade of membership of  $u$  in the intersection of  $A$  and  $B$  is found to be

$$\begin{aligned}\mu_{A \cap B}(u) &= 0.6 / (0.4 + 0.5 + 0.6) + 1 / 0.5 \\ &= medium,\end{aligned}\quad (3.113)$$

which is equivalent to the statement

$$high \wedge medium = medium. \quad (3.114)$$

The same result can be obtained more expeditiously by the use of (3.107).

Thus, we have

$$\begin{aligned}high \wedge medium &= (0.8 / 0.8 + 0.8 / 0.9 + 1 / 1) \wedge (0.6 / 0.4 + \\ &\quad 1 / 0.5 + 0.6 / 0.6) \\ &= 0.6 / 0.4 + 1 / 0.5 + 0.6 / 0.6 \\ &= medium.\end{aligned}\quad (3.115)$$

In a similar fashion, we can extend to fuzzy sets of type 2 the operations of complementation, union, concentration, etc. This will be done in Part II, Sec. 3, in conjunction with our discussion of a fuzzy logic in which the truth-values are linguistic in nature.

Remark 3.2. The results derived in Example 3.13 may be viewed as an instance of a general conclusion that can be drawn from (3.100) concerning an extension of the inequality  $\leq$  from real numbers to fuzzy subsets of the real line. Specifically, in the case of real numbers  $a, b$ , we have the equivalence

$$a \leq b \Leftrightarrow a \wedge b = a. \quad (3.116)$$

Using this as a basis for the extension of  $\leq$  to intervals, we have in virtue of (3.100),

$$[a_1, a_2] \leq [b_1, b_2] \Leftrightarrow a_1 \leq b_1 \text{ \& \& } a_2 \leq b_2. \quad (3.117)$$

This, in turn, leads us to the following definition.

**Definition 3.3.** Let  $A$  and  $B$  be convex fuzzy subsets of the real line, and let  $A_\alpha$  and  $B_\alpha$  denote the  $\alpha$ -level sets of  $A$  and  $B$ , respectively. Then an extension of the inequality  $\leq$  to convex fuzzy subsets of the real line is expressed by<sup>①</sup>

$$A \leq B \Leftrightarrow A \wedge B = A \quad (3.118)$$

$$\Leftrightarrow A_\alpha \wedge B_\alpha = A_\alpha \text{ for all } \alpha \text{ in } [0, 1], \quad (3.119)$$

where  $A_\alpha \wedge B_\alpha$  is defined by (3.100).

In the case of Example 3.13, it is easy to verify by inspection that

$$medium_\alpha \leq high_\alpha \text{ for all } \alpha \quad (3.120)$$

in the sense of (3.119), and hence we can conclude at once that

$$medium \wedge high = medium, \quad (3.121)$$

which is in agreement with (3.114).

## References

- [1] Sir William Thomson, *Popular Lectures and Addresses*, McMillan, London, 1891.
- [2] E. Feigenbaum, *Computers and Thought*, McGraw-Hill, New York, 1963.

---

<sup>①</sup> It can be readily be verified that  $\leq$  as defined by (3.117) constitutes a partial ordering.

- [3] M. Minsky and S. Papert, *Perceptrons; An Introduction to Computational Geometry*, M. I. T. Press, Cambridge, Mass. ,1969.
- [4] M. Arbib, *The Metaphorical Brain*, Wiley-Interscience, New York, 1972.
- [5] A. Newell and H. Simon, *Human Problem Solving*, Prentice-Hall, Englewood Hills, N. J. ,1972.
- [6] L. A. Zadeh, Fuzzy languages and their relation to human and machine intelligence, in *Proc. Int. Conf. on Man and Computer*, Bordeaux, France, S. Karger, Basel, 1972, pp. 130~155.
- [7] L. A. Zadeh, Outline of a new approach to the analysis of complex systems and decision processes, *IEEE Trans. Syst. , Man and Cybern.*, SMC-3, 28~44 (January 1973).
- [8] R. E. Bellman, R. E. Kalaba and L. A. Zadeh, Abstraction and pattern classification, *J. Math. Anal. Appl.* 13, 1~7 (1966).
- [9] M. Black, Reasoning with loose concepts, *Dialogue* 2, 1~12 (1963).
- [10] L. Wittgenstein, Logical form, *Proc. Aristotelian Soc.* 9, 162 ~ 171 (1929).
- [11] M. Scriven, The logic of criteria, *J. Philos.* 56, 857~868 (1959).
- [12] H. Khatchadourian, Vagueness, meaning and absurdity, *Am. Phil. Quart.* 2, 119~129 (1965).
- [13] R. R. Verma, Vagueness and the principle of excluded middle, *Mind* 79, 67~77 (1970).
- [14] J. A. Goguen, The Logic of Inexact Concepts, *Synthese* 19, 325 ~ 373 (1969).
- [15] E. Adams, The logic of "Almost All ", *J. Philos. Logic*, to be published.
- [16] K. Fine, Vagueness, truth and logic, Department of Philosophy, University of Edinburgh, 1973.
- [17] B. S. van Frassen, Presuppositions, supervaluations and free logic, in *The Logical Way of Doing Things* (K. Lambert, Ed. ), Yale U. P. , New Haven Conn. ,1969.
- [18] G. Lakoff, Linguistics and natural logic , in *Semantics of Natural*

- Languages*, (D. David-son and G. Harman, Eds.), D. Reidel, Doudrecht, The Netherlands, 1971.
- [19] L. A. Zadeh, Shadows of fuzzy sets, *Probl. Transfer Inf.* 2, 37 ~ 44 (1966).
- [20] A. Kaufmann, *Theory of Fuzzy Sets*, Masson, Paris, 1972.
- [21] J. Goguen, *L-fuzzy sets*, *J. Math. Anal. Appl.* 18, 145 ~ 174 (1967).
- [22] J. G. Brown, A note on fuzzy sets, *Inf. Control* 18, 32 ~ 39 (1971).
- [23] M. Mizumoto, J. Toyoda and K. Tanaka, General formulation of formal grammars, *Inf. Sci.* 4, 87 ~ 100, 1972.
- [24] L. A. Zadeh, Similarity relations and fuzzy orderings, *Inf. Sci.* 3, 177 ~ 200 (1971).
- [25] R. E. Bellman and L. A. Zadeh, Decision-making in a fuzzy environment, *Manage. Sci.* 17, B-141-B-164 (1970).
- [26] R. E. Bellman and M. Giertz, On the analytic formalism of the theory of fuzzy sets, *Inf. Sci.* 5, 149 ~ 156 (1973).
- [27] L. A. Zadeh, A fuzzy-set-theoretic intrepretation of linguistic hedges, *J. Cybern.* 2, 4 ~ 34 (1972).
- [28] E. F. Codd, Relational completeness of data base sublanguages, in *Courant Computer Science Symposia*, Vol. 6, Prentice-Hall, Englewood Hills, N. J., 1971.
- [29] L. A. Zadeh, Fuzzy sets, *Inf. Control* 8, 338-353, 1965.
- [30] A. Thomasian, *The Structure of Probability Theory With Applications*, McGraw-Hill, New York, 1969.
- [31] R. E. Moore, *Interval Analysis*, Prentice-Hall, Englewood Hills, N. J., 1966.
- [32] J. A. Brzozowski, Regular expressions for linear sequential circuits, *IEEE Trans. Electron Comput.*, EC ~ 14, 148 ~ 156 (1965).
- [33] E. Shamir, Algebraic, Rational and Context-Free Power Series in Noncommuting Variables, in M. Arbib's *Algebraic Theory of Machines, Languages and Semigroups*, Academic, New York, 1968, pp. 329 ~ 341.

- [34] A. Blikle, Equational languages, *Inf. Control* 21, 134~147(1972).
- [35] D. J. Rosenkrantz, Matrix equation and normal forms of context-free grammars, *J. Assoc. Comput. Mach.* 14, 501~507, 1967.
- [36] J. E. Hopcroft and J. D. Ullman, *Formal Languages and Their Relations to Automata*. Addison-Wesley, Reading, Mass., 1969.
- [37] A. V. Aho and J. D. Ullman, *The Theory of Parsing, Translation and Compiling*, Prentice-Hall, Englewood Hills, N. J., 1973.
- [38] G. Lakoff, Hedges: a study in meaning criteria and the logic of fuzzy concepts, in *Proc. 8th Reg. Meeting of Chic. Linguist. Soc.*, Univ. of Chicago Linguistics Dept., April 1972.
- [39] L. A. Zadeh, Semantics of context-free languages, *Math. Syst. Theory*, 2, 127~145(1968).
- [40] L. A. Zadeh, Quantitative fuzzy semantics, *Inf. Sci.* 3, 159~176(1971).
- [41] D. Knuth, Semantics of context-free languages, *Math. Syst. Theory*, 2, 127~145(1968).
- [42] P. Lucas et al., Method and notation for the formal definition of programming languages, Rept. TR 25. 087. IBM Laboratory, Vienna, 1968.
- [43] P. Wegner, The Vienna definition language, *ACM Comput. Surv.* 4, 5~63, (1972).
- [44] J. A. Lee, *Computer Semantics*, Van Nostrand-Reinhold, New York, 1972.
- [45] Z. Kohavi, *Switching and Finite Automata Theory*, McGraw-Hill, New York, 1970.
- [46] G. E. Hughes and M. J. Cresswell, *An Introduction to Modal Logic*, Methuen, London, 1968.
- [47] N. Rescher, *Many-Valued Logics*, McGraw-Hill, New York, 1969.
- [48] R. Barkan, A functional calculus of first order based on strict implication, *J. Symbol. Logic* 11, 1~16(1946).
- [49] L. A. Zadeh, Probability measures of fuzzy events, *J. Math. Anal. Appl.* 23, 421~427(1968).

- [50] A. DeLuca and S. Termini, A definition of non-probabilistic entropy in the setting of fuzzy set theory, *Inf. Control* 20, 201~312(1972).
- [51] J. Hintikka and P. Suppes (Eds. ), *Aspects of Inductive Logic*, North-Holland ,Amsterdam, 1966.
- [52] T. Winograd, *Understanding Natural Language*, Academic, New York, 1972.
- [53] A. DeLuca and S. Termini, Algebraic properties of fuzzy sets, *J. Math. Anal. Appl.* 40, 373~386(1972).
- [54] A. Rosenfeld, Fuzzy groups, *J. Math. Anal. Appl.* 35, 512~517(1971).
- [55] L. A. Zadeh, Fuzzy Algorithms, *Inf. Control* 12, 94~102(1968).
- [56] E. Santos, Fuzzy algorithms, *Inf. Control* 17, 326~339(1970).
- [57] S. K. Chang, On the execution of fuzzy programs using finite state machines, *IEEE Trans. Electron. Comput.* ,C-21, 241~253(1972).
- [58] S. S. L. Chang and L. A. Zadeh, Fuzzy mapping and control *IEEE Trans. Syst. ,Man and Cybern.* ,SMC -2, 30~34(1972).
- [59] E. T. Lee, Fuzzy languages and their relation to automata, Dissertation, Dept. of Electr. Eng. and Comput. Sci. ,Univ. of Calif. ,Berkeley, 1972.
- [60] R. C. T. Lee, Fuzzy logic and the resolution principle, *J. Assoc. Comput. Mach.* 19, 109~119(1972).
- [61] K. M. Colby, S. Weber and F. D. Hill, Artificial paranoia, *J. Artif. Intell.* 2, 1~25(1971).

# The Concept of a Linguistic Variable and its Application to Approximate Reasoning- II

## 1. The concept of a fuzzy variable

Proceeding in the development of Part I of this work, we are now in a position to generalize the concepts introduced in Part I, Sec. 2 to what might be called *fuzzy variables*. For our purposes, it will be convenient to formalize the concept of a fuzzy variable in a way that parallels the characterization of a nonfuzzy variable as expressed by Definition 2.1 of Part I. Specifically:

**Definition 1.1.** A fuzzy variable is characterized by a triple  $(X, U, R(X;u))$ , in which  $X$  is the name of the variable;  $U$  is a universe of discourse (finite or infinite set);  $u$  is a generic name for the elements of  $U$ ; and  $R(X;u)$  is a fuzzy subset of  $U$  which represents a *fuzzy restriction* on the values of  $u$  imposed by  $X$ . [As in the case of nonfuzzy variables,  $R(X;u)$  will usually be abbreviated to  $R(X)$  or  $R(u)$  or  $R(x)$ , where  $x$  denotes a generic name for the values of  $X$ , and  $R(X;u)$  will be referred to as the *restriction on  $u$*  or the *restriction imposed by  $X$* .] The nonrestricted nonfuzzy variable  $u$  constitutes the *base variable* for  $X$ .

The *assignment equation* for  $X$  has the form

$$x = u : R(X) \quad (1.1)$$

and represents an assignment of a value  $u$  to  $x$  subject to the restriction  $R(X)$ .



The degree to which this equation is satisfied will be referred to as the *compatibility of  $u$  with  $R(X)$*  and will be denoted by  $c(u)$ . *By definition,*

$$c(u) = \mu_{R(X)}(u), u \in U \quad (1.2)$$

where  $\mu_{R(X)}(u)$  is the grade of membership of  $u$  in the restriction  $R(X)$ .

Comment 1.1. It is important to observe that the compatibility of  $u$  is not the same as the probability of  $u$ . Thus, the compatibility of  $u$  with  $R(X)$  is merely a measure of the degree to which  $u$  satisfies the restriction  $R(X)$ , and has no relation to how probable or improbable  $u$  happens to be.

Comment 1.2. In terms of the valise analogy (see Part 1, Comment 2.1), a fuzzy variable may be likened to a tagged valise with *soft* sides, with  $X$  representing the name on the tag,  $U$  corresponding to a list of objects which can be put in a valise, and  $R(X)$  representing a sublist of  $U$  in which each object  $u$  is associated with a number  $c(u)$  representing the degree of ease with which  $u$  can be fitted in valise  $X$  (Fig. 1).

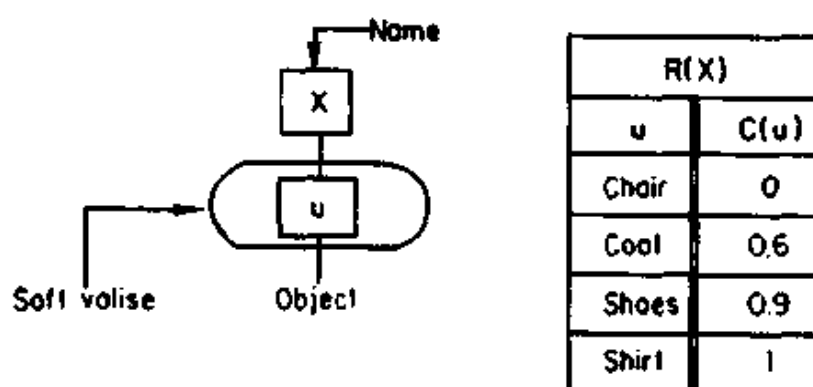

Fig. 1. Valise analogy for a unary fuzzy variable.

In order to simplify the notation it is convenient to use the same symbol for both  $X$  and  $x$ , relying on the context for disambiguation. We do this in the following example.

Example 1.1. Consider a fuzzy variable named *budget*, with  $U = [0, \infty]$  and  $R(X)$  defined by (see Fig. 2)

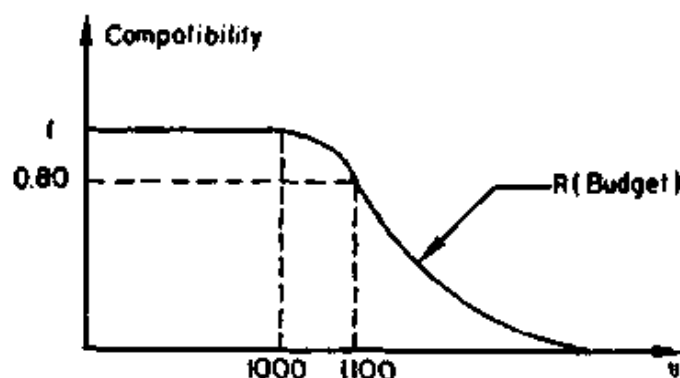

Fig. 2. Compatibility function of *budget*.

$$R(\text{budget}) = \int_0^{1000} 1/u + \int_{1000}^{\infty} \left[ 1 + \left( \frac{u-1000}{200} \right)^2 \right]^{-1} / u. \quad (1.3)$$

Then, in the assignment equation

$$\text{budget} = 1100 : R(\text{budget}), \quad (1.4)$$

the compatibility of 1100 with the restriction imposed by *budget* is

$$\begin{aligned} c(1100) &= \mu_{R(\text{budget})}(1100) \\ &= 0.80. \end{aligned} \quad (1.5)$$

As in the case of nonfuzzy variables, if  $X_1, \dots, X_n$  are fuzzy variables in  $U_1, \dots, U_n$ , respectively, then  $X \triangleq (X_1, \dots, X_n)$  is an *n*-ary composite (joint) variable in  $U = U_1 \times \dots \times U_n$ . Correspondingly, in the *n*-ary assignment equation

$$(x_1, \dots, x_n) = (u_1, \dots, u_n) : R(X_1, \dots, X_n), \quad (1.6)$$

$x_i, i = 1, \dots, n$ , is a generic name for the values of  $X_i$ ;  $u_i$  is a generic name for the elements of  $U_i$ ; and  $R(X) \triangleq R(X_1, \dots, X_n)$  is an  $n$ -ary fuzzy relation in  $U$  which represents the restriction imposed by  $X \triangleq (X_1, \dots, X_n)$ . The compatibility of  $(u_1, \dots, u_n)$  with  $R(X_1, \dots, X_n)$  is defined by

$$c(u_1, \dots, u_n) = \mu_{R(X)}(u_1, \dots, u_n), \quad (1.7)$$

where  $\mu_{R(X)}$  is the membership function of the restriction on  $u \triangleq (u_1, \dots, u_n)$ .

Example 1.2. Suppose that  $U_1 = U_2 = (-\infty, \infty)$ ,  $X_1 \triangleq$  horizontal proximity;  $X_2 \triangleq$  vertical proximity; and the restriction on  $u$  is expressed by

$$R(X) = \int_{U_1 \times U_2} (1 + u_1^2 + u_2^2)^{-1} / (u_1, u_2). \quad (1.8)$$

Then the compatibility of the value  $u = (2, 1)$  in the assignment equation

$$(x_1, x_2) = (2, 1) : R(X) \quad (1.9)$$

is given by

$$\begin{aligned} c(2, 1) &= \mu_{R(X)}(2, 1) \\ &= 0.16. \end{aligned} \quad (1.10)$$

Comment 1.3. In terms of the valise analogy (see Comment 1.2), an  $n$ -ary composite fuzzy variable may be likened to a soft valise named  $X$  with  $n$  compartments named  $X_1, \dots, X_n$ . The compatibility function  $c(u_1, \dots, u_n)$  represents the degree of ease with which objects  $u_1, \dots, u_n$  can be put into respective compartments  $X_1, \dots, X_n$  simultaneously (Fig. 3).

A basic question that arises in connection with an  $n$ -ary assignment equation relates to its decomposition into a sequence

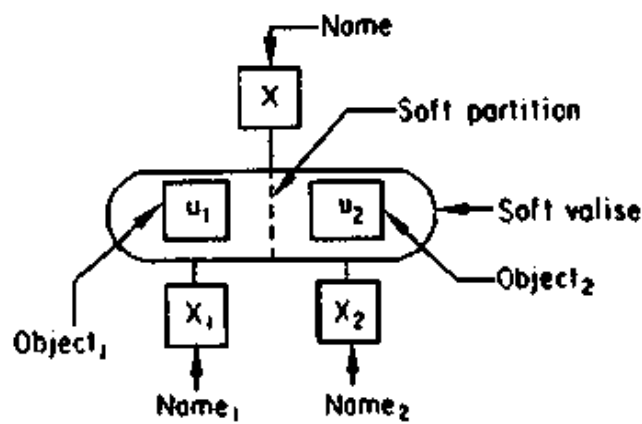

$R(X_1, X_2)$		
$u_1$	$u_2$	$c(u_1, u_2)$
Coat	Shoes	0.8
Coat	Shirt	1
Coat	Coat	0.6

Fig. 3. Valise analogy for a binary fuzzy variable.

of  $n$  unary assignment equations, as in Part I, Eq. (2.21). In the case of fuzzy variables, the process of decomposition is somewhat more involved, and we shall take it up after defining marginal and conditioned restrictions.

*Marginal and conditioned restrictions*

In Part I, Sec. 2, the concepts of marginal and conditioned restrictions were intentionally defined in such a way as to make them easy to extend to fuzzy restrictions. Thus, in the more general context of fuzzy variables, these concepts can be formulated in almost exactly the same terms as in Part I, Sec. 2. This is what we shall do in what follows.

Note 1.1. As we have seen in our earlier discussion of the

notions of marginal and conditioned restrictions in Part I, Sec. 2, it is convenient to simplify the representation of  $n$ -tuples by employing the following notation.

Let

$$q \triangleq (i_1, \dots, i_k) \quad (1.11)$$

be an ordered subsequence of the index sequence  $(1, \dots, n)$ . E. g., for  $n=7, q=(2,4,5)$ .

The ordered complement of  $q$  is denoted by

$$q' = (j_1, \dots, j_m). \quad (1.12)$$

E. g., for  $q=(2,4,5), q'=(1,3,6,7)$ .

A  $k$ -tuple of variables such as  $(v_{i_1}, \dots, v_{i_k})$  is denoted by  $v_{(q)}$ .

Thus

$$v_{(q)} \triangleq (v_{i_1}, \dots, v_{i_k}), \quad (1.13)$$

and similarly

$$v_{(q')} \triangleq (v_{j_1}, \dots, v_{j_m}). \quad (1.14)$$

For example, if

$$v_{(q)} = (v_2, v_4, v_5),$$

then

$$v_{(q')} = (v_1, v_3, v_6, v_7).$$

If  $k=n$ , we shall write more simply

$$v = (v_1, \dots, v_n). \quad (1.15)$$

This notation will be used in the following without further explanation.

**Definition 1.2.** An  $n$ -ary restriction  $R(X_1, \dots, X_n)$  in  $U_1 \times \dots \times U_n$  induces a  $k$ -ary marginal restriction  $R(X_{i_1}, \dots, X_{i_k})$  which is defined as the projection (shadow) of  $R(X_1, \dots, X_n)$  on  $U_{i_1} \times \dots \times U_{i_k}$ . Thus, using the definition of projection [see Part I, Eq.

(3.57)] and employing the notation of Note 1.1, we can express the membership function of the marginal restriction  $R(X_1, \dots, X_k)$  as

$$\mu_{R(X_{(q)})}(u_{(q)}) = \bigvee_{u_{(q')}} \mu_{R(X)}(u). \quad (1.16)$$

**Example 1.3.** For the fuzzy binary variable defined in Example 1.2, we have

$$R_1 \triangleq R(X_1),$$

$$R_2 \triangleq R(X_2),$$

$$\begin{aligned} \mu_{R_1}(u_1) &= \bigvee_{u_2} (1 + u_1^2 + u_2^2)^{-1} \\ &= (1 + u_1^2)^{-1}, \end{aligned}$$

$$\mu_{R_2} = \mu_{R_1}.$$

**Example 1.4.** Assume that

$$U_1 = U_2 = U_3 = 0 + 1 + 2$$

and  $R(X_1, X_2, X_3)$  is a ternary fuzzy relation in  $U_1 \times U_2 \times U_3$  expressed by

$$\begin{aligned} R(X_1, X_2, X_3) &= 0.8/(0,0,0) + 0.6/(0,0,1) + 0.2/(0,1,0) + \\ &1/(1,0,2) + 0.7/(1,1,0) + 0.4/(0,1,1) + \\ &0.9/(1,2,0) + 0.4/(2,1,1) + 0.8/(1,1,2). \end{aligned} \quad (1.17)$$

Applying (1.16) to (1.17), we obtain

$$\begin{aligned} R(X_1, X_2) &= 0.8/(0,0) + 0.4/(0,1) + 1/(1,0) \\ &+ 0.8/(1,1) + 0.9/(1,2) + 0.4/(2,1) \end{aligned} \quad (1.18)$$

and

$$\begin{aligned} R(X_1) &= 0.8/0 + 1/1 + 0.4/2, \\ R(X_2) &= 1/0 + 0.8/1 + 0.9/2. \end{aligned} \quad (1.19)$$

**Definition 1.3.** Let  $R(X_1, \dots, X_n)$  be a restriction on  $(u_1,$

$\dots, u_n$ ), and let  $u_{i_1}^0, \dots, u_{i_k}^0$  be particular values of  $u_{i_1}, \dots, u_{i_k}$ , respectively. If in the membership function of  $R(X_1, \dots, X_n)$  the values of  $u_{i_1}, \dots, u_{i_k}$  are set equal to  $u_{i_1}^0, \dots, u_{i_k}^0$ , then the resulting function of the arguments  $u_{j_1}, \dots, u_{j_m}$ , where the index sequence  $q' = (j_1, \dots, j_m)$  is complementary to  $q = (i_1, \dots, i_k)$ , is defined to be the membership function of a *conditioned restriction*  $R(X_{j_1}, \dots, X_{j_m} | u_{i_1}^0, \dots, u_{i_k}^0)$  or, more simply,  $R(X_{(q')} | u_{(q)}^0)$ . Thus

$$\mu_{R(X_{j_1}, \dots, X_{j_m} | u_{i_1}^0, \dots, u_{i_k}^0)}(u_{j_1}, \dots, u_{j_m}) = \mu_{R(X_1, \dots, X_n)}(u_1, \dots, u_n | u_{i_1} = u_{i_1}^0, \dots, u_{i_k} = u_{i_k}^0),$$

or more compactly,

$$\mu_{R(X_{(q')} | u_{(q)}^0)}(u_{(q')}) = \mu_{R(X)}(u | u_{(q)} = u_{(q)}^0). \quad (1.20)$$

The simplicity of the relation between conditioned and unconditioned restrictions becomes more transparent if the  $u_i^0$  are written without the superscript. Then, (1.20) becomes

$$\mu_{R(X_{j_1}, \dots, X_{j_m} | u_{i_1}, \dots, u_{i_k})}(u_{j_1}, \dots, u_{j_m}) \triangleq \mu_{R(X_1, \dots, X_n)}(u_1, \dots, u_n),$$

or more compactly,

$$\mu_{R(X_{(q')} | u_{(q)})}(u_{(q')}) \triangleq \mu_{R(X)}(u). \quad (1.21)$$

Note 1.2. In some instances, it is preferable to use an alternative notation for conditioned restrictions. For example, if  $n = 4$ ,  $q = (1, 3)$  and  $q' = (2, 4)$ , it may be simpler to write  $R(u_1^0, X_2, u_3^0, X_4)$  for  $R(X_2, X_4 | u_1^0, u_3^0)$ . This is particularly true when numerical values are used in place of the subscripted arguments, e. g., 5 and 2 in place of  $u_1^0$  and  $u_3^0$ . In such cases, in order to avoid ambiguity we shall write explicitly  $R(X_2, X_4 | u_1^0 = 5, u_3^0 = 2)$ , or more simply,  $R(5, X_2, 2, X_4)$ .

Example 1.5. In Example 1.4, we have

$$\begin{aligned}
R(X_1, X_2, 0) &= 0.8/(0,0) + 0.2/(0,1) + 0.7/(1,1) + 0.9/(1,2), \\
R(X_1, X_2, 1) &= 0.6/(0,0) + 0.4/(0,1) + 0.4/(2,1), \\
R(X_1, X_2, 2) &= 1/(1,0) + 0.8/(1,1),
\end{aligned}
\tag{1.22}$$

and, using (1.16),

$$\begin{aligned}
R(X_1, 0) &= 0.8/0 + 1/1, \\
R(X_1, 1) &= 0.4/0 + 0.8/1 + 0.4/2, \\
R(X_1, 2) &= 0.9/1.
\end{aligned}
\tag{1.23}$$

It is useful to observe that an immediate consequence of the definitions of marginal and conditioned restrictions is the following

**Proposition 4.1.** *Let  $R(X_{j_1}, \dots, X_{j_m})$  be a marginal restriction induced by  $R(X_1, \dots, X_n)$ , and let  $R(X_{j_1}, \dots, X_{j_m} | u_{i_1}, \dots, u_{i_k})$  or, more simply,  $R(X_{(q')} | u_{(q)})$  be a restriction conditioned on  $u_{i_1}, \dots, u_{i_k}$ , with  $q = (i_1, \dots, i_k)$  and  $q' = (j_1, \dots, j_m)$  being complementary index sequences. Then, in consequence of (1.16), (1.21) and the definition of the union [see Part 1, Eq. (3.34)], we can assert that*

$$R(X_{(q')}) = \sum_{u_{(q)}} R(X_{(q')} | u_{(q)}), \tag{1.24}$$

where  $\sum_{u_{(q)}}$  stands for the union (rather than the arithmetic sum) over the  $u_{(q)}$ .

**Example 1.6.** With reference to Example 1.3 and Note 1.2, it is easy to verify that

$$R(X_1, X_2) = R(X_1, X_2, 0) + R(X_1, X_2, 1) + R(X_1, X_2, 2)$$

and

$$R(X_1) = R(X_1, 0) + R(X_1, 1) + R(X_1, 2).$$



*Separability and noninteraction*

Definition 1.4 An  $n$ -ary restriction  $R(X_1, \dots, X_n)$  is *separable* iff it can be expressed as the Cartesian product of unary restrictions

$$R(X_1, \dots, X_n) = R(X_1) \times \dots \times R(X_n) \quad (1.25)$$

or, equivalently, as the intersection of cylindrical extensions [see Part I, Eq. (3.62)]

$$R(X_1, \dots, X_n) = \bar{R}(X_1) \cap \dots \cap \bar{R}(X_n). \quad (1.26)$$

It should be noted that, if  $R(X_1, \dots, X_n)$  is normal, then so are its marginal restrictions (see Part I, Proposition 3.3). It follows, then, that the  $R(X_i)$  in (1.25) are marginal restrictions induced by  $R(X_1, \dots, X_n)$ . For, (1.25) implies that

$$\mu_{R(X_1, \dots, X_n)}(u_1, \dots, u_n) = \mu_{R(X_1)}(u_1) \wedge \dots \wedge \mu_{R(X_n)}(u_n), \quad (1.27)$$

and hence by Eq. (3.57) of Part I,

$$P_i R(X_1, \dots, X_n) = R(X_i), \quad i = 1, \dots, n. \quad (1.28)$$

Unless stated to the contrary, we shall assume henceforth that  $R(X_1, \dots, X_n)$  is normal.

Example 1.7. The relation matrix of the restriction shown below can be expressed as the max-min dyadic product of a column vector (a unary relation) and a row vector (a unary relation). This implies that the restriction in question is separable:

$$\begin{bmatrix} 0.3 & 0.8 & 0.8 & 0.1 \\ 0.3 & 0.8 & 1 & 0.1 \\ 0.2 & 0.2 & 0.2 & 0.1 \\ 0.3 & 0.6 & 0.6 & 0.1 \end{bmatrix} = \begin{bmatrix} 0.8 \\ 1 \\ 0.2 \\ 0.6 \end{bmatrix} [0.3 \quad 0.8 \quad 1 \quad 0.1]$$

Example 1.8. The restrictions defined in Definition 1.2 and Example 1.3 are not separable.

An immediate consequence of separability is the following

Proposition 4.2. *If  $R(X_1, \dots, X_n)$  is separable, so is every marginal restriction induced by  $R(X_1, \dots, X_n)$ .*

Also, in consequence of (1.25), we can assert the

Proposition 4.3. *The separable restriction  $R(X_1) \times \dots \times R(X_n)$  is the largest restriction with marginal restrictions  $R(X_1), \dots, R(X_n)$ .*

The concept of separability is closely related to that of *noninteraction* of fuzzy variables. More specifically:

Definition 1.5. The fuzzy variables  $X_1, \dots, X_n$  are said to be *noninteractive* iff the restriction  $R(X_1, \dots, X_n)$  is separable.

It will be recalled that, in the case of nonfuzzy variables, the justification for characterizing  $X_1, \dots, X_n$  as noninteractive is that if [see Part 1, Eq. (2.18)]

$$R(X_1, \dots, X_n) = R(X_1) \times \dots \times R(X_n), \quad (1.29)$$

then the  $n$ -ary assignment equation

$$(x_1, \dots, x_n) = (u_1, \dots, u_n) : R(X_1, \dots, X_n) \quad (1.30)$$

can be decomposed into a sequence of  $n$  unary assignment equations

$$\begin{aligned} x_1 &= u_1 : R(X_1), \\ &\cdot \quad \cdot \quad \cdot \\ x_n &= u_n : R(X_n). \end{aligned} \quad (1.31)$$

In the case of fuzzy variables, a basic consequence of noninteraction—from which Eq. (2.19) of Part 1 follows as a special case—is expressed by

Proposition 4.4. *If the fuzzy variables  $X_1, \dots, X_n$  are noninteractive, then the  $n$ -ary assignment equation (1.30) can be decomposed into a sequence of  $n$  unary assignment equations*

(1.31), with the understanding that if  $c(u_1, \dots, u_n)$  is the compatibility of  $(u_1, \dots, u_n)$  with  $R(X_1, \dots, X_n)$ , and if  $c_i(u_i)$ ,  $i = 1, \dots, n$ , is the compatibility of  $u_i$  with  $R(X_i)$ , then

$$c(u_1, \dots, u_n) = c_1(u_1) \wedge \dots \wedge c_n(u_n). \quad (1.32)$$

*Proof.* By the definitions of compatibility, noninteraction and separability, we have at once

$$\begin{aligned} c(u_1, \dots, u_n) &= \mu_{R(X_1, \dots, X_n)}(u_1, \dots, u_n) \\ &= \mu_{R(X_1)}(u_1) \wedge \dots \wedge \mu_{R(X_n)}(u_n) \\ &= c_1(u_1) \wedge \dots \wedge c_n(u_n). \quad \text{Q. E. D.} \end{aligned} \quad (1.33)$$

Comment 1.4. Pursuing the valise analogy further (see Comment 1.3), noninteractive fuzzy variables  $X_1, \dots, X_n$  may be likened to  $n$  separate soft valises with name-tags  $X_1, \dots, X_n$ . The restriction associated with valise  $X_i$  is characterized by the compatibility function  $c(u_i)$ . Then the overall compatibility function for the valises  $X_1, \dots, X_n$  is given by (1.32) (Fig. 4).

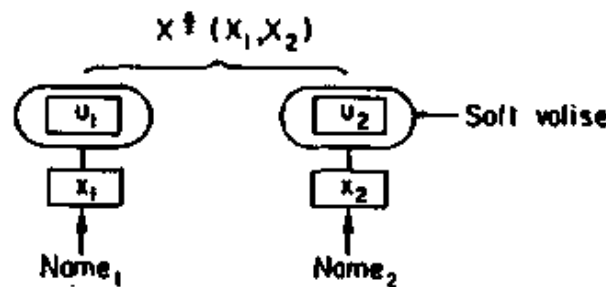

Fig. 4. Valise analogy for noninteractive fuzzy variables.

Comment 1.5. In terms of the base variables of  $X_1, \dots, X_n$  (see Definition 1.1), noninteraction implies that there are no constraints which jointly involve  $u_1, \dots, u_n$ , where  $u_i$  is the base

variable for  $X_i, i=1, \dots, n$ . For example, if the  $u_i$  are constrained by

$$u_1 + \dots + u_n = 1,$$

then  $X_1, \dots, X_n$  are *interactive*, i. e., are not noninteractive. (See Part I, Comment 3.5.)

If  $X_1, \dots, X_n$  are interactive, it is still possible to decompose an  $n$ -ary assignment equation into a sequence of  $n$  unary assignment equations. However, the restriction on  $u_i$  will, in general, depend on the values assigned to  $u_1, \dots, u_{i-1}$ . Thus, the  $n$  assignment equations will have the following form [see also Part I, Eq. (2.21)]:

$$\begin{aligned} x_1 &= u_1 : R(X_1), \\ x_2 &= u_2 : R(X_2 | u_1), \\ x_3 &= u_3 : R(X_3 | u_1, u_2), \\ &\cdot \quad \cdot \quad \cdot \\ x_n &= u_n : R(X_n | u_1, \dots, u_{n-1}), \end{aligned} \tag{1.34}$$

where  $R(X_i | u_1, \dots, u_{i-1})$  denotes the restriction on  $u_i$  conditioned on  $u_1, \dots, u_{i-1}$  (see Definition 1.3).

**Example 1.9.** Taking Example 1.4, assume that  $u_1=1, u_2=2$  and  $u_3=0$ .

Then

$$\begin{aligned} R(X_1) &= 0.8/0 + 1/1 + 0.4/2, \\ R(X_2 | u_1=1) &= 1/0 + 0.8/1 + 0.9/2, \\ R(X_3 | u_1=1, u_2=2) &= 0.9/0, \end{aligned} \tag{1.35}$$

so that

$$\begin{aligned} c_1(1) &= 1, \\ c_2(2) &= 0.9, \\ c_3(0) &= 0.9. \end{aligned} \tag{1.36}$$

As in the case of (1.31), the justification for (1.34) is provided by

Proposition 4.5. *If  $X_1, \dots, X_n$  are interactive fuzzy variables subject to the restriction  $R(X_1, \dots, X_n)$ , and  $c_i(u_i), i = 1, \dots, n$ , is the compatibility of  $u_i$  with the conditioned restriction  $R(X_i | u_1, \dots, u_{i-1})$  in (1.34), then*

$$c(u_1, \dots, u_n) = c_1(u_1) \wedge \dots \wedge c_n(u_n), \quad (1.37)$$

where  $c(u_1, \dots, u_n)$  is the compatibility of  $(u_1, \dots, u_n)$  with  $R(X_1, \dots, X_n)$ .

*Proof.* By the definition of a conditioned restriction [see (1.20)], we have, for all  $i, 1 \leq i \leq n$ ,

$$\mu_{R(X_i | u_1, \dots, u_{i-1})}(u_i) = \mu_{R(X_1, \dots, X_i)}(u_1, \dots, u_i). \quad (1.38)$$

On the other hand, the definition of a marginal restriction [see (1.16)] implies that, for all  $i$  and all  $u_1, \dots, u_i$ , we have

$$\mu_{R(X_1, \dots, X_i)}(u_1, \dots, u_i) \geq \mu_{R(X_1, \dots, X_{i+1})}(u_1, \dots, u_{i+1}), \quad (1.39)$$

and hence that

$$\begin{aligned} & \mu_{R(X_{i+1} | u_1, \dots, u_i)}(u_{i+1}) \wedge \mu_{R(X_i | u_1, \dots, u_{i-1})}(u_i) \\ & = \mu_{R(X_{i+1} | u_1, \dots, u_i)}(u_{i+1}). \end{aligned} \quad (1.40)$$

Combining (1.40) with the defining equation

$$c_i(u_i) = \mu_{R(X_i | u_1, \dots, u_{i-1})}(u_i), \quad (1.41)$$

we derive

$$c(u_1, \dots, u_n) = c_1(u_1) \wedge \dots \wedge c_n(u_n). \quad \text{Q. E. D.} \quad (1.42)$$

This concludes our discussion of some of the properties of fuzzy variables which are relevant to the concept of a linguistic variable. In the following section, we shall formalize the concept of a linguistic variable and explore some of its implications.

## 2. The concept of a linguistic variable

In our informal discussion of the concept of a linguistic variable in Part I, Sec. 1, we have stated that a linguistic variable differs from a numerical variable in that its values are not numbers but words or sentences in a natural or artificial language. Since words, in general, are less precise than numbers, the concept of a linguistic variable serves the purpose of providing a means of approximate characterization of phenomena which are too complex or too ill-defined to be amenable to description in conventional quantitative terms. More specifically, the fuzzy sets which represent the restrictions associated with the values of a linguistic variable may be viewed as summaries of various subclasses of elements in a universe of discourse. This, of course, is analogous to the role played by words and sentences in a natural language. For example, the adjective *handsome* is a summary of a complex of characteristics of the appearance of an individual. It may also be viewed as a label for a fuzzy set which represents a restriction imposed by a fuzzy variable named *handsome*. From this point of view, then, terms *very handsome*, *not handsome*, *extremely handsome*, *quite handsome*, etc., are names of fuzzy sets which result from operating on the fuzzy set named *handsome* with the modifiers named *very*, *not*, *extremely*, *quite*, etc. In effect, these fuzzy sets, together with the fuzzy set labeled *handsome*, play the role of values of the linguistic variable *Appearance*.

An important facet of the concept of a linguistic variable is that it is a variable of a higher order than a fuzzy variable, in the

sense that a linguistic variable takes fuzzy variables as its values. For example, the values of a linguistic variable named *Age* might be: *young*, *not young*, *old*, *very old*, *not young and not old*, *quite old*, etc., each of which is the name of a fuzzy variable. If  $X$  is the name of such a fuzzy variable, the restriction imposed by  $X$  may be interpreted as the *meaning* of  $X$ . Thus, if the restriction imposed by the fuzzy variable named *old* is a fuzzy subset of  $U = [0, 100]$  defined by

$$R(\text{old}) = \int_{50}^{100} \left[ 1 + \left( \frac{u-50}{5} \right)^{-2} \right]^{-1} / u, u \in U, \quad (2.1)$$

then the fuzzy set represented by  $R(\text{old})$  may be taken to be the meaning of *old* (Fig. 5).

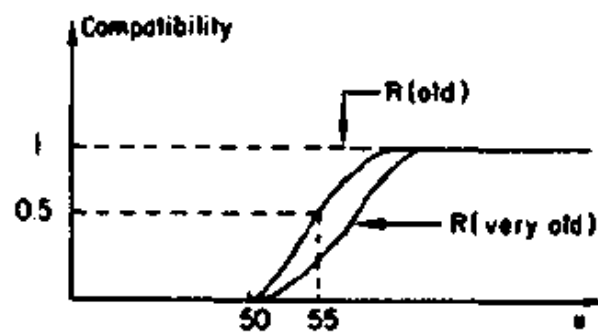

Fig. 5. Compatibility functions of *old* and *very old*.

Another important facet of the concept of a linguistic variable is that, in general, a linguistic variable is associated with two rules: (1) a *syntactic rule*, which may have the form of a grammar for generating the names of the values of the variable; and (2) a *semantic rule* which defines an algorithmic procedure for computing the meaning of each value. These rules constitute an

essential part of the characterization of a *structured* linguistic variable. <sup>①</sup>

Since a linguistic variable is a variable of a higher order than a fuzzy variable, its characterization is necessarily more complex than that expressed by Definition 1. 1. More specifically, we have

**Definition 2. 1.** A linguistic variable is characterized by a quintuple  $(\mathcal{X}, T(\mathcal{X}), U, G, M)$  in which  $\mathcal{X}$  is the name of the variable;  $T(\mathcal{X})$  (or simply  $T$ ) denotes the *term-set* of  $\mathcal{X}$ , that is, the set of names of *linguistic values* of  $\mathcal{X}$ , with each value being a fuzzy variable denoted generically by  $X$  and ranging over a universe of discourse  $U$  which is associated with the *base variable*  $u$ ;  $G$  is a *syntactic rule* (which usually has the form of a grammar) for generating the names,  $X$ , of values of  $\mathcal{X}$ ; and  $M$  is a *semantic rule* for associating with each  $X$  its *meaning*,  $M(X)$ , which is a fuzzy subset of  $U$ . A particular  $X$ , that is, a name generated by  $G$ , is called a *term*. A term consisting of a word or words which function as a unit (i. e., always occur together) is called an *atomic term*. A term which contains one or more atomic terms is a *composite term*. A concatenation of components of a composite term is a *subterm*. If  $X_1, X_2, \dots$  are terms in  $T$ , then  $T$  may be expressed as the union

$$T = X_1 + X_2 + \dots \quad (2. 2)$$

Where it is necessary to place in evidence that  $T$  is generated by a grammar  $G$ ,  $T$  will be written as  $T(G)$ .

The meaning,  $M(X)$ , of a term  $X$  is defined to be the

---

<sup>①</sup> It is primarily the semantic rule that distinguishes a linguistic variable from the more conventional concept of a syntactic variable.



restriction,  $R(X)$ , on the base variable  $u$  which is imposed by the fuzzy variable named  $X$ . Thus

$$M(X) \triangleq R(X), \quad (2.3)$$

with the understanding that  $R(X)$ —and hence  $M(X)$ —may be viewed as a fuzzy subset of  $U$  carrying the name  $X$ . The connection between  $\mathcal{X}$ , the linguistic value  $X$  and the base variable  $u$  is illustrated in Fig. 3 of Part I.

Note 2.1. In order to avoid a profusion of symbols, it is expedient to assign more than one meaning to some of the symbols occurring in Definition 2.1, relying on the context for disambiguation. Specifically:

(a) We shall frequently employ the symbol  $\mathcal{X}$  to denote both the name of the variable and the generic name of its values. Likewise,  $X$  will be used to denote both the generic name of the values of the variable and the name of the variable itself.

(b) The same symbol will be used to denote a set and the name of that set. Thus, the symbols  $X$ ,  $M(X)$  and  $R(X)$  will be used interchangeably, although strictly speaking  $X$ —as the name of  $M(X)$  [or  $R(X)$ ]—is distinct from  $M(X)$ . In other words, when we say that a term  $X$  (e. g. *young*) is a value of  $\mathcal{X}$  (e. g. , *Age*), it should be understood that the actual is  $M(X)$  and that  $X$  is merely the name of the value.

Example 2.1. Consider a linguistic variable named *Age*, i. e. ,  $\mathcal{X} = \textit{Age}$ , with  $U = [0, 100]$ . A linguistic value of *Age* might be named *old*, with *old* being an atomic term. Another value might be named *very old*, in which case *very old* is a composite term which contains *old* as an atomic component and has *very* and *old* as subterms. The value of *Age* named *more or less young*

is a composite term which contains *young* as an atomic term and in which *more or less* is a subterm. The term-set associated with *Age* may be expressed as

$$T(\text{Age}) = \text{old} + \text{very old} + \text{no old} + \text{more or less young} + \\ \text{quite young} + \text{not very old and not very young} + \\ \dots, \quad (2.4)$$

in which each term is the name of a fuzzy variable in the universe of discourse  $U = [0, 100]$ . The restriction imposed by a term, say  $R(\text{old})$ , constitutes the meaning of *old*. Thus, if  $R(\text{old})$  is defined by (2.1), then the meaning of the linguistic value *old* is given by

$$M(\text{old}) = \int_{50}^{100} \left[ 1 + \left( \frac{u-50}{5} \right)^{-2} \right]^{-1} / u, \quad (2.5)$$

or more simply (see Note 2.1),

$$\text{old} = \int_{50}^{100} \left[ 1 + \left( \frac{u-50}{5} \right)^{-2} \right]^{-1} / u. \quad (2.6)$$

Similarly, the meaning of a linguistic value such as *very old* may be expressed (see Fig. 5)

$$M(\text{very old}) = \text{very old} = \int_{50}^{100} \left[ 1 + \left( \frac{u-50}{5} \right)^{-2} \right]^{-2} / u. \quad (2.7)$$

The assignment equation in the case of a linguistic variable assumes the form

$$X = \text{term in } T(\mathcal{A}) \\ = \text{name generated by } G \quad (2.8)$$

which implies that the meaning assigned to  $X$  is expressed by

$$M(X) = R(\text{term in } T(\mathcal{A})). \quad (2.9)$$

In other words, the meaning of  $X$  is given by the application of the semantic rule  $M$  to the value assigned to  $X$  by the right-hand

side of (2.8). Furthermore, as defined by (2.3),  $M(X)$  is identical to the restriction imposed by  $X$ .

Comment 2.1. In accordance with Note 2.1 (a), the assignment equation will usually be written as

$$\mathcal{X} = \text{name in } T(\mathcal{X}) \quad (2.10)$$

rather than in the form (2.8). For example, if  $\mathcal{X} = \text{Age}$ , and *old* is a term in  $T(\mathcal{X})$ , we shall write

$$\text{Age} = \text{old}, \quad (2.11)$$

with the understanding that *old* is a restriction on the values of  $u$  defined by (2.1), which is assigned by (2.11) to the linguistic variable named *Age*. It is important to note that the equality symbol in (2.10) does not represent a symmetric relation — as it does in the case of arithmetic equality. Thus, it would not be meaningful to write (2.11) as

$$\text{old} = \text{Age}$$

To illustrate the concept of a linguistic variable, we shall consider first a very elementary example in which  $T(\mathcal{X})$  contains just a few terms and the syntactic and semantic rules are trivially simple.

Example 2.2. Consider a linguistic variable named *Number* which is associated with the finite term-set

$$T(\text{Number}) = \text{few} + \text{several} + \text{many}, \quad (2.12)$$

in which each term represents a restriction on the values of  $u$  in the universe of discourse

$$U = 1 + 2 + 3 + \dots + 10. \quad (2.13)$$

These restrictions are assumed to be fuzzy subsets of  $U$  which are defined as follows:

$$\text{few} = 0.4/1 + 0.8/2 + 1/3 + 0.4/4, \quad (2.14)$$

$$\text{several} = 0.5/3 + 0.8/4 + 1/5 + 1/6 + 0.8/7 + 0.5/8, \quad (2.15)$$

$$\text{many} = 0.4/6 + 0.7/7 + 0.8/8 + 0.9/9 + 1/10. \quad (2.16)$$

Thus

$$R(\text{few}) = M(\text{few}) = 0.4/1 + 0.8/2 + 1/3 + 0.4/4, \quad (2.17)$$

and likewise for the other terms in  $T$ . The implication of (2.17) is that *few* is the name of a fuzzy variable which is a value of the linguistic variable *Number*. The meaning of *few* — which is the same as the restriction imposed by *few* — is a fuzzy subset of  $U$  which is defined by the right-hand side of (2.17).

To assign a value such as *few* to the linguistic variable *Number*, we write

$$\text{Number} = \text{few}, \quad (2.18)$$

with the understanding that what we actually assign to *Number* is a fuzzy variable named *few*.

**Example 2.3.** In this case, we assume that we are dealing with a composite linguistic variable<sup>①</sup> named  $(\mathcal{X}, \mathcal{Y})$  which is associated with the base variable  $(u, v)$  ranging over the universe of discourse  $U \times V$ , where

$$U \times V = (1+2+3+4) \times (1+2+3+4) \quad (2.19)$$

$$= (1,1) + (1,2) + (1,3) + (1,4)$$

...

...

$$+ (4,1) + (4,2) + (4,3) + (4,4), \quad (2.20)$$

with the understanding that

---

① Composite linguistic variables will be discussed in greater detail in Sec. 3 in connection with linguistic truth variables.

$$i \times j = (i, j), i, j = 1, 2, 3, 4. \quad (2.21)$$

Furthermore, we assume that the term-set of  $(\mathcal{X}, \mathcal{Y})$  comprises just two terms:

$$T = \textit{approximately equal} + \textit{more or less equal}, \quad (2.22)$$

where *approximately equal* and *more or less equal* are names of binary fuzzy relations defined by the relation matrix

$$\textit{approximately equal} = \begin{bmatrix} 1 & 0.6 & 0.4 & 0.2 \\ 0.6 & 1 & 0.6 & 0.4 \\ 0.4 & 0.6 & 1 & 0.6 \\ 0.2 & 0.4 & 0.6 & 1 \end{bmatrix} \quad (2.23)$$

and

$$\textit{more or less equal} = \begin{bmatrix} 1 & 0.8 & 0.6 & 0.4 \\ 0.8 & 1 & 0.8 & 0.6 \\ 0.6 & 0.8 & 1 & 0.8 \\ 0.4 & 0.6 & 0.8 & 1 \end{bmatrix} \quad (2.24)$$

In these relation matrices, the  $(i, j)$ th entry represents the compatibility of the pair  $((i, j))$  with the restriction in question. For example, the  $(2, 3)$  entry in *approximately equal*-which is 0.6-is the compatibility of the ordered pair  $(2, 3)$  with the binary restriction named *approximately equal*.

To assign a value, say *approximately equal*, to  $(\mathcal{X}, \mathcal{Y})$ , we write

$$(\mathcal{X}, \mathcal{Y}) = \textit{approximately equal}, \quad (2.25)$$

where, as in (2.18), it is understood that what we assign to  $(\mathcal{X}, \mathcal{Y})$  is a binary fuzzy relation named *approximately equal*, which is a binary restriction on the values of  $(u, v)$  in the universe of discourse (2.20).

Comment 2.2. In terms of the valise analogy (see Comment

1. 2), a linguistic variable as defined by Definition 2.1 may be likened to a hard valise into which we can put soft valises, as illustrated in Fig. 6. A soft valise corresponds to a fuzzy variable which is assigned as a linguistic value to  $\mathcal{X}$ , with  $X$  playing the role of the name-tag of the soft valise.

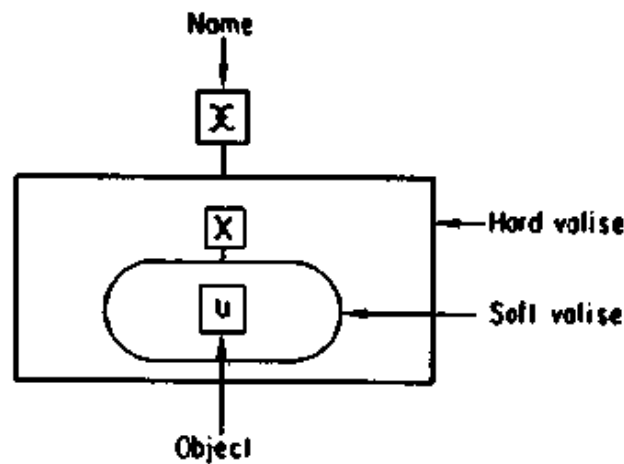

Fig. 6. Valise analogy for a linguistic variable.

### *Structured linguistic variables*

In both of the above examples the term-set contains only a small number of terms, so that it is practicable to list the elements of  $T(\mathcal{X})$  and set up a direct association between each element and its meaning. In the more general case, however, the number of elements in  $T(\mathcal{X})$  may be infinite, necessitating the use of an algorithm, rather than a table look-up procedure, for generating the elements of  $T(\mathcal{X})$  as well as for computing their meaning.

A linguistic variable  $\mathcal{X}$  will be said to be structured if its term-set,  $T(\mathcal{X})$ , and the function,  $M$ , which associates a meaning with each term in the term-set, can be characterized algorithmically. In this sense, the syntactic and semantic rules

associated with a structured linguistic variable may be viewed as algorithmic procedures for generating the elements of  $T(\mathcal{A})$  and computing the meaning of each term in  $T(\mathcal{A})$ , respectively. Unless stated to the contrary, we shall assume henceforth that the linguistic variables we deal with are structured.

**Example 2.4.** As a very simple illustration of the role played by the syntactic and semantic rules in the case of a structured linguistic variable, we shall consider a variable named *Age* whose terms are exemplified by: *old*, *very old*, *very very old*, *very very very old*, etc. Thus, the term set of *Age* can be written as

$$T(\textit{Age}) = \textit{old} + \textit{very old} + \textit{very very old} + \dots \quad (2.26)$$

In this simple case, it is clear by inspection that every term in  $T(\textit{Age})$  is of the form *old* or *very very...very old*. To deduce this rule in a more general way, we proceed as follows.

Let  $xy$  denote the concatenation of character strings  $x$  and  $y$ , e. g. ,  $x = \textit{very}$ ,  $y = \textit{old}$ ,  $xy = \textit{very old}$ . If  $A$  and  $B$  are sets of strings, e. g. ,

$$A = x_1 + x_2 + \dots, \quad (2.27)$$

$$B = y_1 + y_2 + \dots, \quad (2.28)$$

where  $x_i$  and  $y_j$  are character strings, then the concatenation of  $A$  and  $B$  is denoted by  $AB$  and is defined as the set of strings

$$\begin{aligned} AB &= (x_1 + x_2 + \dots)(y_1 + y_2 + \dots) \\ &= \sum_{i,j} x_i y_j \end{aligned} \quad (2.29)$$

For example, if  $A = \textit{very}$  and  $B = \textit{old} + \textit{very old}$ , then

$$\textit{very}(\textit{old} + \textit{very old}) = \textit{very old} + \textit{very very old}. \quad (2.30)$$

Using this notation, the given expression for  $T(\textit{Age})$ , or

simply  $T$ , may be taken to be the solution of the equation<sup>①</sup>

$$T = old + very T, \quad (2.31)$$

which, in words, means that every term in  $T$  is of the form *old* or *very* followed by some term in  $T$ .

Equation (2.31) can be solved by iteration, using the recursion equation

$$T^{i+1} = old + very T^i, i = 0, 1, 2, \dots, \quad (2.32)$$

with the initial value of  $T^i$  being the empty set  $\theta$ . Thus

$$\begin{aligned} T^0 &= \theta, \\ T^1 &= old, \\ T^2 &= old + very old, \\ T^3 &= old + very old + very very old, \\ &\dots, \end{aligned} \quad (2.33)$$

and the solution of (2.31) is given by

$$T = T^\infty = old + very old + very very old + very very very old + \dots. \quad (2.34)$$

For the example under consideration, the syntactic rule, then, is expressed by (2.31) and its solution (2.34). Equivalently, the syntactic rule can be characterized by the production system

$$T \rightarrow old, \quad (2.35)$$

$$T \rightarrow very T, \quad (2.36)$$

for which (2.31) plays the role of an algebraic representation.<sup>②</sup> In

① As is well known in the theory of regular expressions (see [32]), the solution of (2.31) can be expressed as

$$T = (\lambda + very + very^2 + \dots) old,$$

where  $\lambda$  is the null string. This expression for  $T$  is equivalent to that of (2.34).

② A discussion of the algebraic representation of context-free grammars may be found in [33], [34] and [35]. Algebraic treatment of fuzzy languages is discussed in [6] and [58].



this case, a term in  $T$  can be generated through a standard derivation procedure ([ 36 ], [ 37 ]) involving a successive application of the rewriting rules (2. 35) and (2. 36) starting with the symbol  $T$ . Thus, if  $T$  is rewritten as *very T* and then  $T$  in *very T* is rewritten as *old*, we obtain the term *very old*. In a similar fashion, the term *very very very old* can be obtained from  $T$  by the derivation chain

$$\begin{aligned} T &\rightarrow \textit{very T} \rightarrow \textit{very very T} \rightarrow \textit{very very very T} \\ &\rightarrow \textit{very very very old}. \end{aligned} \quad (2. 37)$$

Turning to the semantic rule for *Age*, we note that to compute the meaning of a term such as *very...very old* we need to know the meaning of *old* and the meaning of *very*. The term *old* plays the role of a *primary term*, that is, a term whose meaning must be specified as an initial datum in order to provide a basis for the computation of the meaning of composite terms in  $T$ . As for the term *very*, it acts as a *linguistic hedge*, that is, as a modifier of the meaning of its operand. If—as very simple approximation—we assume that *very* acts as a concentrator [see Part I, Eq. (3. 40)], then

$$\begin{aligned} \textit{very old} &= \text{CON}(\textit{old}) \\ &= \textit{old}^2. \end{aligned} \quad (2. 38)$$

Consequently, the semantic rule for *Age* may be expressed as

$$M(\textit{very...very old}) = \textit{old}^{2^n}, \quad (2. 39)$$

where  $n$  is the number of occurrences of *very* in the term *very...very old* and  $M(\textit{very...very old})$  is the meaning of *very...very old*.

Furthermore, if the primary term *old* is defined as

$$\textit{old} = \int_{50}^{100} \left[ 1 + \left( \frac{u-50}{5} \right)^{-2} \right]^{-1} / u, \quad (2. 40)$$

then

$$M(\text{very}\cdots\text{very old}) = \int_{50}^{100} \left[ 1 + \left( \frac{u-50}{5} \right)^{-2} \right]^{-2n} / u, n=1,2,\dots. \quad (2.41)$$

This equation provides an explicit semantic rule for the computation of the meaning of composite terms generated by (2.31), from the knowledge of the meaning of the primary term *old* and the hedge *very*.

#### *Boolean linguistic variables*

The linguistic variable considered in Example 2.4 is a special case of what might be called a *Boolean linguistic variable*. Typically, such a variable involves a finite number of primary terms, a finite number of hedges, the connectives *and* and *or*, and the negation *not*. For example, the term-set of a Boolean linguistic variable *Age* might be

$$\begin{aligned} T(\text{Age}) = & \text{young} + \text{old} + \text{not young} + \text{not old} + \text{very young} + \\ & \text{very very young} + \text{not very young} \text{ and } \text{not very old} \\ & + \text{quite young} + \text{more or less old} + \text{extremely old} + \\ & \dots \end{aligned} \quad (2.42)$$

More formally, a Boolean linguistic variable may be defined recursively as follows.

**Definition 2.2.** A *Boolean linguistic variable* is a linguistic variable whose terms,  $X$ , are Boolean expressions in variables of the form  $X_p, hX_p, X$  or  $hX$ , where  $h$  is a linguistic hedge,  $X_p$  is a primary term and  $hX$  is the name of a fuzzy set resulting from acting with  $h$  on  $X$ .

As an illustration, in the case of the linguistic variable *Age* whose term-set is defined by (2.42), the term *not very young and*

*not very old* is of this form, with  $h \triangleq \text{very}$ ,  $X_p \triangleq \text{young}$  and  $X_p \triangleq \text{old}$ . Similarly, in the case of the term *very very young*,  $h \triangleq \text{very very}$  and  $X_p \triangleq \text{young}$ .

Boolean linguistic variables are particularly convenient to deal with because much of our experience in the manipulation and evaluation of Boolean expressions is transferable to variables of this type. To illustrate this point, we shall consider a simple example which involves two primary terms and a single hedge.

Example 2.5. Let *Age* be a Boolean linguistic variable with the term-set

$$T(\text{Age}) = \text{young} + \text{not young} + \text{old} + \text{not old} + \text{very young} + \text{not young and not old} + \text{young or old} + \text{young or (not very young and not very old)} + \dots \quad (2.43)$$

If we identify *and* with intersection, *or* with union, *not* with complementation and *very* with concentration [see (2.38)], the meaning of a typical value of *Age* can be written down by inspection. For example,

$$\begin{aligned} M(\text{not young}) &= \neg \text{young}, \\ M(\text{not very young}) &= \neg (\text{young}^2), \\ M(\text{not very young and not very old}) &= \neg (\text{young}^2) \cap \neg (\text{old}^2), \\ M(\text{young or old}) &= \text{young} \cup \text{old}. \end{aligned} \quad (2.44)$$

In effect, these equations express the meaning of a composite term as a function of the meanings of its constituent primary terms. Thus, if *young* and *old* are defined as

$$\text{young} = \int_0^{25} 1/u + \int_{25}^{100} \left[ 1 + \left( \frac{u-25}{5} \right)^2 \right]^{-1} / u, \quad (2.45)$$

$$old = \int_{50}^{100} \left[ 1 + \left( \frac{u-50}{5} \right)^{-2} \right]^{-1} / u, \quad (2.46)$$

then (see Fig. 7)

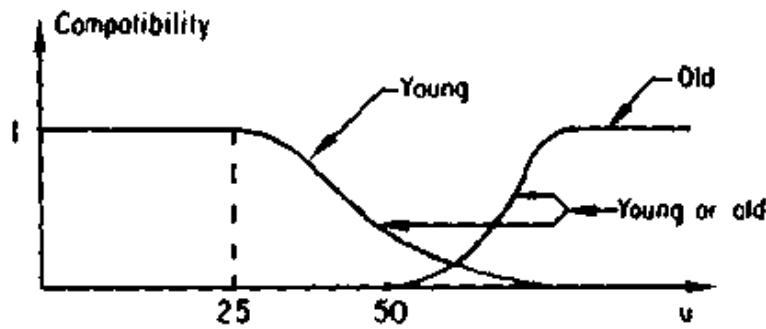

Fig. 7. Compatibility function for *young or old*.

$$\begin{aligned} M(\text{young or old}) &= \int_0^{25} 1/u + \int_{25}^{50} \left[ 1 + \left( \frac{u-25}{5} \right)^2 \right]^{-1} / u \\ &\quad + \int_{50}^{100} \left[ 1 + \left( \frac{u-25}{5} \right)^2 \right]^{-1} \\ &\quad \vee \left[ 1 + \left( \frac{u-50}{5} \right)^{-2} \right]^{-1} / u. \end{aligned} \quad (2.47)$$

The linguistic variable considered in the above example involves just one type of hedge, namely, *very*. More generally, a Boolean linguistic variable may involve a finite number of hedges, as in (2.42). The procedure for computing the meaning of a composite term remains the same, however, once the operations corresponding to the hedges are defined.

The question of what constitutes an appropriate representation for a particular hedge, e. g., *more or less* or *quite* or

essentially, is by no means a simple one. <sup>(1)</sup>To illustrate the point, in some contexts the effect of the hedge *more or less* may be approximated by [see Part I, Eq. (3.41)]

$$M(\text{more or less } X) = \text{DIL}(X) = X^{0.5}. \quad (2.48)$$

For example, if  $X = \text{old}$ , and *old* is defined by (2.46), then

$$\text{more or less old} = \int_{50}^{100} \left[ 1 + \left( \frac{u-50}{5} \right)^{-2} \right]^{-0.5} / u. \quad (2.49)$$

In many instances, however, *more or less* acts as a fuzzifier in the sense of Part I, Eq. (3.48), rather than as a dilator. As an illustration, suppose that the meaning of a primary term *recent* is specified as

$$\text{recent} = 1/1974 + 0.8/1973 + 0.7/1972, \quad (2.50)$$

and that *more or less recent* is defined as the result of acting with a fuzzifier  $F$  on *recent*, i. e. ,

$$\text{more or less recent} = F(\text{recent}; K) \quad (2.51)$$

where the kernel  $K$  of  $F$  is defined by

$$\begin{aligned} K(1974) &= 1/1974 + 0.9/1973, \\ K(1973) &= 1/1973 + 0.9/1972, \\ K(1972) &= 1/1972 + 0.8/1971. \end{aligned} \quad (2.52)$$

On substituting the values of  $K$  into (3.48) of Part I, we obtain the meaning of *more or less recent*, i. e. ,

$$\text{more or less recent} = 1/1974 + 0.9/1973 + 0.72/1972 + 0.56/1971. \quad (2.53)$$

On the other hand, if the hedge *more or less* were assumed to be a

---

① A more detailed discussion of linguistic hedges from a fuzzy-set-theoretic point of view may be found in [27] and [38]. The idea of treating various types of linguistic hedges as operators on fuzzy sets originated in the course of the author's collaboration with Professor G. Lakoff.

dilator, then we would have

$$\begin{aligned} \text{more or less recent} &= (1/1974 + 0.8/1973 + 0.7/1972)^{0.5} \\ &= 1/1974 + 0.9/1973 + 0.84/1972 \quad (2.54) \end{aligned}$$

which differs from (2.53) mainly in the absence of the term  $0.56/1971$ . Thus, if this term were of importance in the definition of *more or less recent*, then the approximation to *more or less* by a dilator would not be a good one.

In Example 2.5, we have deduced the semantic rule by inspection, taking advantage of our familiarity with the evaluation of Boolean expressions. To illustrate a more general technique, we shall consider the same linguistic variable as in Example 2.10, but use a method [39] which is an adaptation of the approach employed by Knuth in [40] to define the semantics of contextfree languages.

Example 2.6 It can readily be verified that the term-set of Example 2.5 is generated by a context-free grammar  $G = (V_T, V_N, T, P)$  in which the nonterminals (syntactic categories) are denoted by  $T, A, B, C, D$ , i. e. ,

$$V_N = T + A + B + C + D + E, \quad (2.55)$$

while the set of terminals (components of terms in  $T$ ) is expressed by

$$V_T = \text{young} + \text{old} + \text{very} + \text{not} + \text{and} + \text{or} + (+), \quad (2.56)$$

and the production system,  $P$ , is given by

$$\begin{aligned} T &\rightarrow A, & C &\rightarrow D \\ T &\rightarrow T \text{ or } A, & C &\rightarrow E, \\ A &\rightarrow B, & D &\rightarrow \text{very } D, \\ A &\rightarrow A \text{ and } B, & E &\rightarrow \text{very } E, \end{aligned} \quad (2.57)$$

$$\begin{aligned}
 B &\rightarrow C, & D &\rightarrow \textit{young}, \\
 B &\rightarrow \textit{not } C, & E &\rightarrow \textit{old}, \\
 C &\rightarrow (T).
 \end{aligned}$$

The production system,  $P$ , can also be represented in an algebraic form as the set of equations (see Footnote 3)

$$\begin{aligned}
 T &= A + T \textit{ or } A, \\
 A &= B + A \textit{ and } B, \\
 B &= C + \textit{not } C, \\
 C &= (T) + D + E, & (2.58) \\
 D &= \textit{very } D + \textit{young}, \\
 E &= \textit{very } E + \textit{old}.
 \end{aligned}$$

The solution of this set of equations for  $T$  yields the term set  $T$  as expressed by (2.43). Similarly, the solutions for  $A, B, C, D$  and  $E$  yield sets of terms which constitute the syntactic categories denoted by  $A, B, C, D$  and  $E$ , respectively. The solution of (2.58) can be obtained iteratively, as in (2.32), by using the recursion equation

$$\begin{aligned}
 (T, A, B, C, D, E)^{i+1} &= f((T, A, B, C, D, E)^i), \\
 i &= 0, 1, 2, \dots, & (2.59)
 \end{aligned}$$

with

$$(T, A, B, C, D, E)^0 = (\theta, \dots, \theta)$$

where  $(T, A, B, C, D, E)$  is a sextuple whose components are the nonterminals in (2.58);  $f$  is the mapping defined by the system of equations (2.58);  $\theta$  is the empty set; and  $(T, A, B, C, D, E)^i$  is the  $i$ th iterate of  $(T, A, B, C, D, E)$ . The solution of (2.58), which is the fixed point of  $f$ , is given by  $(T, A, B, C, D, E)^\infty$ . However, it is true for all  $i$  that

$$(T, A, B, C, D, E)^i \subset (T, A, B, C, D, E), \quad (2.60)$$

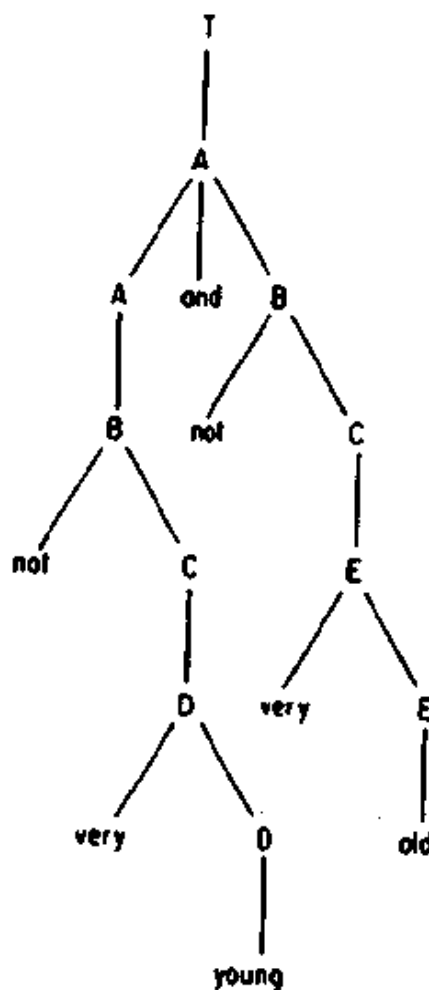

Fig. 8. Syntax tree for *not very young and not very old*.

which means that every component in the sextuple on the left of (2.60) is a subset of the corresponding component on the right of (2.60). The implication of (2.60), then, is that we generate more and more terms in each of the syntactic categories  $T, A, B, C, D, E$  as we iterate (2.59) on  $i$ .

In a more conventional fashion, a term in  $T$ , say *not very young and not very old*, is generated by  $G$  through a succession of substitutions (derivations) involving the productions in  $P$ , with each derivation chain starting with  $T$  and terminating on a term



generated by  $G$ . For example, the derivation chain for the term *not very young and not very old* is (see also Example 2.4),

$$\begin{aligned}
 T \rightarrow A \rightarrow A \text{ and } B \rightarrow B \text{ and } B \rightarrow \text{not } C \text{ and } B \rightarrow \text{not } D \text{ and } B \rightarrow \\
 \text{not very } D \text{ and } B \rightarrow \text{not very young and } B \rightarrow \text{not very} \\
 \text{young and not } C \rightarrow \text{not very young and not } E \rightarrow \text{not very} \\
 \text{young and not very } E \rightarrow \text{not very young and not very old.}
 \end{aligned}
 \tag{2.61}$$

This derivation chain can be deduced from the syntax (parse) tree shown in Fig. 8, which exhibits the phrase structure of the term *not very young and not very old* in terms of the syntactic categories  $T, A, B, C, D, E$ . In effect, this procedure for generating the terms in  $T$  by the use of the grammar  $G$  constitutes the syntactic rule for the variable *Age*.

The semantic rule for *Age* is *induced* by the syntactic rule described above in the sense that the meaning of a term in  $T$  is determined, in part, by its syntax tree. Specifically, each production in (2.57) is associated with a relation between the fuzzy sets labeled by the corresponding terminal and nonterminal symbols. The resulting dual system of productions and associated equations has the appearance shown below, with the subscripts  $L$  and  $R$  serving to differentiate between the symbols on the left- and right-hand sides of a production ( $+ \underline{\Delta}$  union):

$$T \rightarrow A \quad \Rightarrow T_L = A_R, \tag{2.62}$$

$$T \rightarrow T \text{ or } A \quad \Rightarrow T_L = T_R + A_R, \tag{2.63}$$

$$A \rightarrow B \quad \Rightarrow A_L = B_R, \tag{2.64}$$

$$A \rightarrow A \text{ and } B \quad \Rightarrow A_L = A_R \cap B_R, \tag{2.65}$$

$$B \rightarrow C \quad \Rightarrow B_L = C_R, \tag{2.66}$$

$$B \rightarrow \text{not } C \quad \Rightarrow B_L = \neg C_R, \tag{2.67}$$

$$C \rightarrow (T) \quad \Rightarrow C_L = T_R, \quad (2.68)$$

$$C \rightarrow D \quad \Rightarrow C_L = D_R, \quad (2.69)$$

$$C \rightarrow E \quad \Rightarrow C_L = E_R, \quad (2.70)$$

$$D \rightarrow \text{very } D \quad \Rightarrow D_L = (D_R)^2, \quad (2.71)$$

$$E \rightarrow \text{very } E \quad \Rightarrow E_L = (E_R)^2, \quad (2.72)$$

$$D \rightarrow \text{young} \quad \Rightarrow D_L = \text{young}, \quad (2.73)$$

$$E \rightarrow \text{old} \quad \Rightarrow E_L = \text{old}. \quad (2.74)$$

This dual system is employed in the following manner to compute the meaning of a composite term in  $T$ .

1. The term in question, e. g. , *not very young and not very old* ,is parsed by the use of an appropriate parsing algorithm for  $G$  [37],yielding a syntax tree such as shown in Fig. 8. The leaves of this syntax tree are (a) primary terms whose meaning is specified *a priori*; (b) names of modifiers (i. e. , hedges, connectives ,negation,etc. );and (c)markers such as parentheses which serve as aids to parsing.

2. Starting from the bottom, the primary terms are assigned their meaning and, using the equations of (2.62), the meaning of nonterminals connected to the leaves is computed. Then the subtrees which have these nonterminals as their roots are deleted, leaving the nonterminals in question as the leaves of the pruned tree. This process is repeated until the meaning of the term associated with the root of the syntax tree is computed.

In applying this procedure to the syntax tree shown in Fig. 9, we first assign to *young* and *old* the meanings expressed by (2.45) and (2.46). Then, using (2.73) and (2.74), we find

$$D_7 = \text{young} \quad (2.75)$$

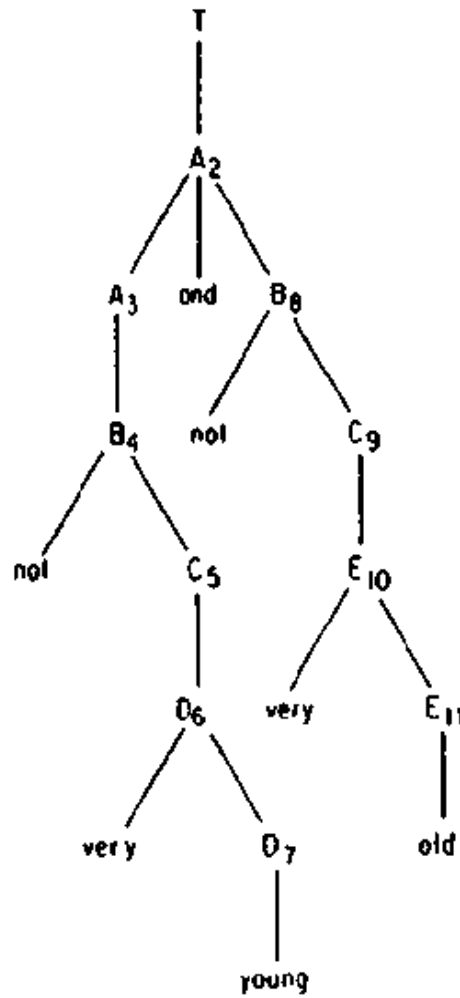

Fig. 9. Computation of the meaning of *not very young and not very old*.

and

$$E_{11} = \text{old}. \quad (2.76)$$

Next, using (2.71) and (2.72), we obtain

$$D_6 = D_7^2 = \text{young}^2 \quad (2.77)$$

and

$$E_{10} = E_{11}^2 = \text{old}^2 \quad (2.78)$$

Continuing in this manner, we obtain

$$C_5 = D_6 = \text{young}^2, \quad (2.79)$$

$$C_9 = E_{10} = \text{old}^2, \quad (2.80)$$

$$B_1 = \neg C_5 = \neg(\text{young}^2), \quad (2.81)$$

$$B_8 = \neg C_9 = \neg(\text{old}^2), \quad (2.82)$$

$$A_3 = B_4 = \neg(\text{young}^2), \quad (2.83)$$

$$A_2 = A_3 \cap B_8 = \neg(\text{young}^2) \cap \neg(\text{old}^2), \quad (2.84)$$

and hence

$$\text{not very young and not very old} = \neg(\text{young}^2) \cap \neg(\text{old}^2),$$

which agrees with the expression which we had obtained previously by inspection [see(2.44)].

The basic idea behind the procedure described above is to relate the meaning of a composite term to that of its constituent primary terms by means of a system of equations which are determined by the grammar which generates the terms in  $T$ . In the case of the Boolean linguistic variable of Example 2.5, this can be done by inspection. More generally, the nature of the hedges in the linguistic variable and its grammar  $G$  might be such as to make the computation of the meaning of its values a nontrivial problem.

#### *Graphical representation of a linguistic variable*

A linguistic variable may be represented in a graphical form which is similar to that of an object in the Vienna definition language [41,42,43]. Specifically, a variable  $\mathcal{X}$  is represented as a fan (see Fig. 10) whose root is labeled  $\mathcal{X}$  and whose edges are labeled with the names of the values of  $\mathcal{X}$ , i. e.,  $X_1, X_2, \dots$ . The object attached to the edge labeled  $X_i$  is the meaning of  $X_i$ . For example, in the case of the variable named *Age*, the edges might be labeled *young*, *old*, *not young*, etc., and the meaning of each such label can be represented as the graph of the membership function of the fuzzy set which is the meaning of the label in

question (Fig. 11). It is important to note that, in the case of a structured linguistic variable, both the labels of the edges and the objects attached to them are generated algorithmically by the syntactic and semantic rules which are associated with the variable.

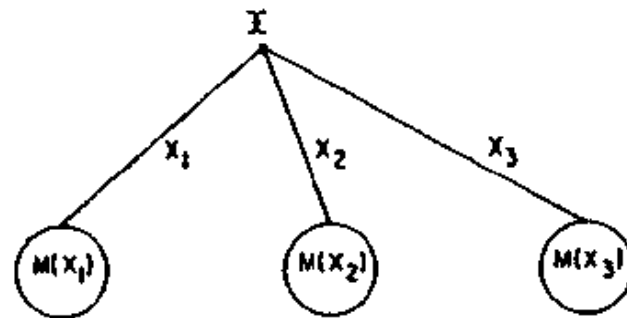

Fig. 10. Representation of a linguistic variable as a Vienna definition language object.

More generally, the graph of a linguistic variable may have the form of a tree rather than a single fan (see Fig. 12). In the case of a tree, it is understood that the name of a value of the variable is the concatenation of the names associated with an upward path from the leaf to the root. For example, in the tree of Fig. 12, the composite name associated with the path leading from node 3 to the root is *very tall, quite fat, extremely intelligent*.

This concludes our discussion of some of the basic aspects of the concept of a linguistic variable. In the following section and Part II, we shall focus our attention on some of the applications of this concept.

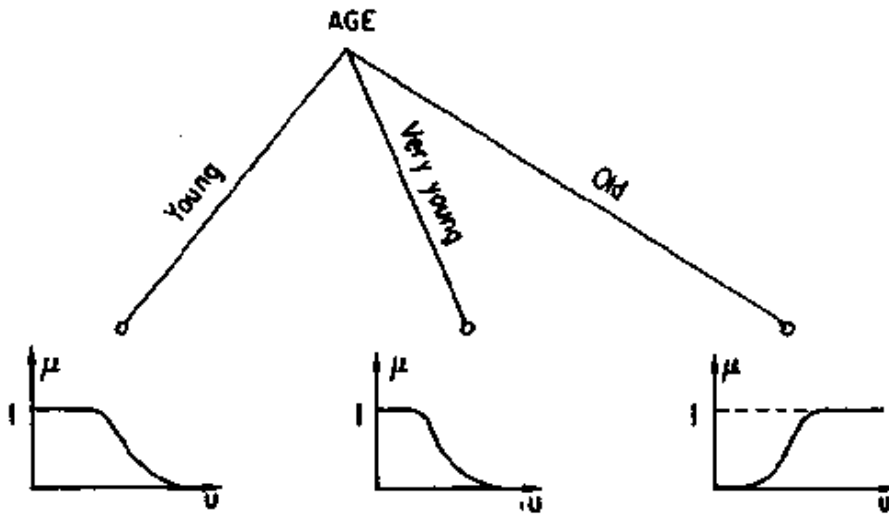

Fig. 11. Representation of the linguistic variable *Age* as a Vienna definition language object.

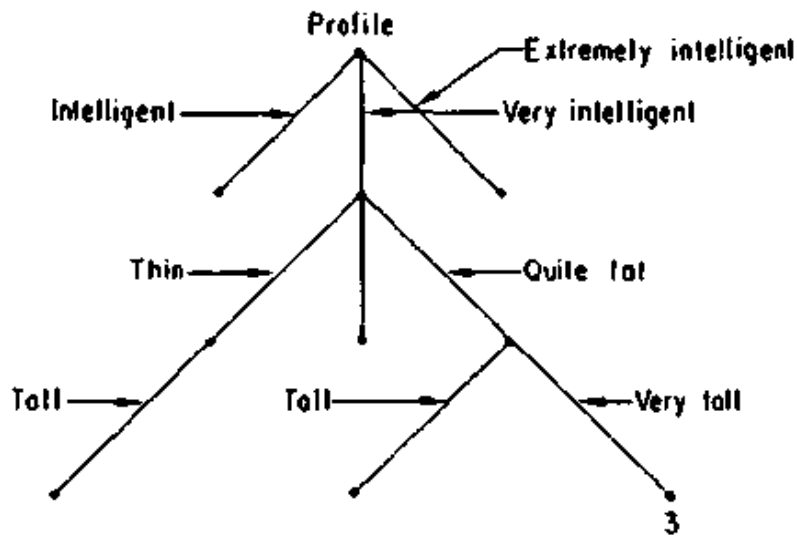

Fig. 12. Tree representation of the linguistic variable *Profile*.

### 3. Linguistic truth variables and fuzzy logic

In everyday discourse, we frequently characterize the degree of truth of a statement by expressions such as *very true*, *quite true*, *more or less true*, *essentially true*, *false*, *completely false*, etc. The similarity between these expressions and the values of a linguistic variable suggests that in situations in which the truth or falsity of an assertion is not well defined, it may be appropriate to treat *Truth* as a linguistic variable for which *true* and *false* are merely two of the primary terms in its term-set rather than a pair of extreme points in the universe of truth-values. Such a variable and its values will be called a *linguistic truth variable* and *linguistic truth-values*, respectively.

Treating truth as a linguistic variable leads to a *fuzzy linguistic logic*, or simply *fuzzy logic*, which is quite different from the conventional two-valued or even  $n$ -valued logic. This fuzzy logic provides a basis for what might be called *approximate reasoning*, that is, a mode of reasoning in which the truth-values and the rules of inference are fuzzy rather than precise. In many ways, approximate reasoning is akin to the reasoning used by humans in ill-defined or unquantifiable situations. Indeed, it may well be the case that much — perhaps most — of human reasoning is approximate rather than precise in nature.

In the sequel, the term *proposition* will be employed to denote statements of the form " $u$  is  $A$ ," where  $u$  is a name of an object and  $A$  is the name of a possibly fuzzy subset of a universe of discourse  $U$ , e. g., "John is young," "X is small," "apple is

red," etc. If  $A$  is interpreted as a fuzzy predicate,<sup>①</sup> then the statement " $u$  is  $A$ " may be paraphrased as " $u$  has property  $A$ ." Equivalently, " $u$  is  $A$ " may be interpreted as an assignment equation in which a fuzzy set named  $A$  is assigned as a value to a linguistic variable which denotes an attribute of  $u$ , e. g. ,

John is young  $\leftrightarrow$   $Age(\text{John}) = \text{young}$

$X$  is small  $\leftrightarrow$   $Magnitude(X) = \text{small}$

apple is red  $\leftrightarrow$   $Color(\text{apple}) = \text{red}$

A proposition such as " $u$  is  $A$ " will be assumed to be associated with two fuzzy subsets; (i) The meaning of  $A$ ,  $M(A)$ , which is a fuzzy subset of  $U$  named  $A$ ; and (ii) the *truth-value* of " $u$  is  $A$ ," or simply *truth-value* of  $A$ , which is denoted by  $v(A)$  and is defined to be a possibly fuzzy subset of a universe of truth-values,  $V$ . In the case of two-valued logic,  $V = T + F$  ( $T \triangleq$  true,  $F \triangleq$  false). In what follows, unless stated to the contrary, it will be assumed that  $V = [0, 1]$ .

A truth-value which is a point in  $[0, 1]$ , e. g.  $v(A) = 0.8$ , will be referred to as a *numerical* truth-value. The numerical truth-values play the role of the values of the base variable for the linguistic variable *Truth*. The linguistic values of *Truth* will be referred to as *linguistic truth-values*. More specifically, we shall assume that *Truth* is the name of a Boolean linguistic variable in which the primary term is *true*, with *false* defined not

---

① More precisely, a fuzzy predicate may be viewed as the equivalent of the membership function of a fuzzy set. To simplify our terminology, both  $A$  and  $\mu_A$  will be referred to as a fuzzy predicate.



as the negation of *true*,<sup>①</sup> but as its mirror image with respect to the point 0.5 in  $[0,1]$ . Typically, the term-set of *Truth* will be assumed to be the following:

$$\begin{aligned}
 T(\text{Truth}) = & \text{true} + \text{not true} + \text{very true} + \text{more or less true} + \\
 & \text{very very true} + \text{essentially true} + \text{very(not true)} \\
 & + \text{not very true} + \dots + \text{false} + \text{not false} + \text{very} \\
 & \text{false} + \dots + \dots \text{not very true and not very false} + \\
 & \dots, \tag{3.1}
 \end{aligned}$$

in which the terms are the names of the truth-values.

The meaning of the primary term *true* is assumed to be a fuzzy subset of the interval  $V = [0, 1]$  characterized by a membership function of the form shown in Fig. 13. More precisely, *true* should be regarded as the name of a fuzzy variable whose restriction is the fuzzy set depicted in Fig. 13.

A possible approximation to the membership function of *true* is provided by the expression

$$\begin{aligned}
 \mu_{\text{true}}(v) = & 0 && \text{for } 0 \leq v \leq a \\
 & = 2 \left( \frac{v-a}{1-a} \right)^2 && \text{for } a \leq v \leq \frac{a+1}{2} \\
 & = 1 - 2 \left( \frac{v-1}{1-a} \right)^2 \\
 & \text{for } \frac{a+1}{2} \leq v \leq 1, \tag{3.2}
 \end{aligned}$$

which has  $v = (1+a)/2$  as its crossover point. (Note that the support of *true* is the interval  $[a, 1]$ .) Correspondingly, for *false*, we have (see Fig. 13)

---

① As will be seen later (3.11), the definition of *false* as the mirror image of *true* is a consequence of defining *false* as the truth-value of *not A* under the assumption that the truth-value of *A* is *true*.

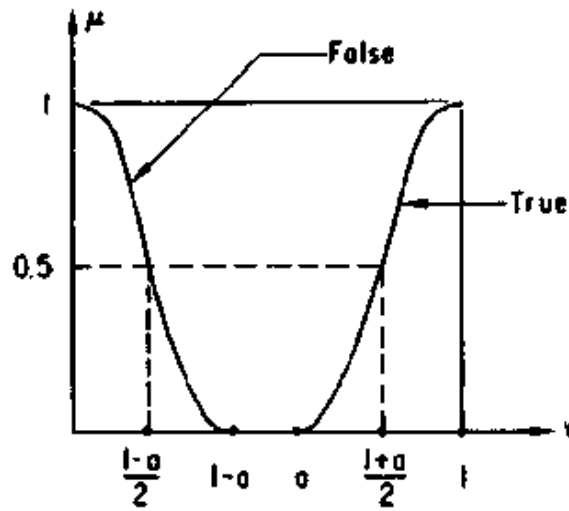

Fig. 13. Compatibility functions of linguistic truth-values *true* and *false*.

$$\mu_{false}(v) = \mu_{true}(1-v), 0 \leq v \leq 1.$$

In some instances it is simpler to assume that *true* is a subset of the finite universe of truth-values

$$V = 0 + 0.1 + 0.2 + \dots + 0.9 + 1 \quad (3.3)$$

rather than of the unit interval  $V = [0, 1]$ . With this assumption, *true* may be defined as, say,

$$true = 0.5/0.7 + 0.7/0.8 + 0.9/0.9 + 1/1,$$

where the pair 0.5/0.7, for example, means that the compatibility of the truth-value 0.7 with *true* is 0.5.

In what follows, our main concern will be with relations of the general form

$$\begin{aligned} v & (u \text{ is } ; \text{linguistic value of a Boolean linguistic variable } \mathcal{A}) \\ & = \text{linguistic value of a Boolean linguistic truth variable } \mathcal{F} \end{aligned} \quad (3.4)$$

as in

$$v(\text{John is tall and dark and handsome}) \\ = \text{not very true and not very false,}$$

where *tall and dark and handsome* is a linguistic value of a variable named  $\mathcal{H} \triangleq \text{Appearance}$ , and *not very true and not very false* is that of a linguistic truth variable  $\mathcal{F}$ . In abbreviated form, (3.4) will usually be written as

$$v(X) = T,$$

where  $X$  is a linguistic value of  $\mathcal{H}$  and  $T$  is that of  $\mathcal{F}$ .

Now suppose that  $X_1, X_2$  and  $X_1 * X_2$ , where  $*$  is a binary connective, are linguistic values of  $\mathcal{H}$  with respective truth-values  $v(X_1), v(X_2)$  and  $v(X_1 * X_2)$ . A basic question that arises in this connection is whether or not it is possible to express  $v(X_1 * X_2)$  as a function of  $v(X_1)$  and  $v(X_2)$ , that is, write

$$v(X_1 * X_2) = v(X_1) *' v(X_2), \quad (3.5)$$

where  $*'$  is a binary connective associated with the linguistic truth variable  $\mathcal{F}$ <sup>①</sup>. It is this question that provides the motivation for the following discussion.

#### *Logical connectives in fuzzy logic*

To construct a basis for fuzzy logic it is necessary to extend the meaning of such logical operations as negation, disjunction, conjunction and implication to operands which have linguistic rather than numerical truth-values. In other words, given propositions  $A$  and  $B$ , we have to be able to compute the truth-value of, say,  $A$  and  $B$  from the knowledge of the linguistic

---

① From an algebraic point of view,  $v$  may be regarded as a homomorphic mapping from  $T(\mathcal{H})$ , the term-set of  $\mathcal{H}$ , to  $T(\mathcal{F})$ , the term-set of  $\mathcal{F}$ , with  $*'$  representing the operation in  $T(\mathcal{F})$  induced by  $*$ .

truth-values of  $A$  and  $B$ .

In considering this problem it is helpful to observe that, if  $A$  is a fuzzy subset of a universe of discourse  $U$  and  $u \in U$ , then the two statements

(a) The grade of membership of  $u$  in the fuzzy set  $A$  is  $\mu_A(u)$ .

(b) The truth-value of the fuzzy predicate  $A$  is  $\mu_A(u)$ .

(3.6)

are equivalent. Thus, the question "What is the truth-value of  $A$  and  $B$  given the linguistic truth-values of  $A$  and  $B$ ?" is similar to the question to which we had addressed ourselves in Part I, Sec. 3, namely, "What is the grade of membership of  $u$  in  $A \cap B$  given the fuzzy grades of membership of  $u$  in  $A$  and  $B$ ?"

To answer the latter question we made use of the extension principle. The same procedure will be followed to extend the meaning of *not*, *and*, *or* and *implies* to linguistic truth-values.

Specifically, if  $v(A)$  is a point in  $V = [0, 1]$  representing the truth-value of the proposition " $u$  is  $A$ ," (or simply  $A$ ), where  $u$  is an element of a universe of discourse  $U$ , then truth-value of *not*  $A$  (or  $\neg A$ ) is given by

$$v(\text{not } A) = 1 - v(A). \quad (3.7)$$

Now suppose that  $v(A)$  is not a point in  $[0, 1]$  but a fuzzy subset of  $[0, 1]$  expressed as

$$v(A) = u_1/v_1 + \dots + u_n/v_n, \quad (3.8)$$

where the  $v_i$  are points in  $[0, 1]$  and the  $u_i$  are their grades of membership in  $v(A)$ . Then, by applying the extension principle [Part I, Eq. (3.80)] to (3.7), we obtain the expression for  $v(\text{not } A)$  as a fuzzy subset of  $[0, 1]$ , i. e. ,

$$v(\text{not } A) = u_1/(1-v_1) + \dots + u_n/(1-v_n). \quad (3.9)$$

In particular, if the truth-value of  $A$  is *true*, i. e. ,

$$v(A) = \text{true}, \quad (3.10)$$

then the truth-value *false* may be defined as

$$\text{false} \triangleq v(\text{not } A). \quad (3.11)$$

For example, if

$$\text{true} = 0.5/7 + 0.7/0.8 + 0.9/0.9 + 1/1, \quad (3.12)$$

then the truth-value of *not A* is given by

$$\text{false} = v(\text{not } A) = 0.5/0.3 + 0.7/0.2 + 0.9/0.1 + 1/0.$$

Comment 3.1. It should be noted that if

$$\text{true} = \mu_1/v_1 + \dots + \mu_n/v_n, \quad (3.13)$$

then by (3.33) of Part I ,

$$\text{not true} = (1-\mu_1)/v_1 + \dots + (1-\mu_n)/v_n. \quad (3.14)$$

By contrast, if

$$v(A) = \text{true} = \mu_1/v_1 + \dots + \mu_n/v_n, \quad (3.15)$$

then

$$\text{false} = v(\text{not } A) = \mu_1/(1-v_1) + \dots + \mu_n/(1-v_n). \quad (3.16)$$

The same applies to hedges. For example, by the definition of *very* [see (2.38)],

$$\text{very true} = \mu_1^2/v_1 + \dots + \mu_n^2/v_n. \quad (3.17)$$

On the other hand, the truth-value of *very A* is expressed by

$$v(\text{very } A) = \mu_1/v_1^2 + \dots + \mu_n/v_n^2. \quad (3.18)$$

Turning our attention to binary connectives, let  $v(A)$  and  $v(B)$  be the linguistic truth-values of propositions  $A$  and  $B$ , respectively. To simplify the notation, we shall adopt the convention of writing—as in the case where  $v(A)$  and  $v(B)$  are points in  $[0,1]$ —

$$v(A) \wedge v(B) \text{ for } v(A \text{ and } B), \quad (3.19)$$

$$v(A) \vee v(B) \text{ for } v(A \text{ or } B), \quad (3.20)$$

$$v(A) \Rightarrow v(B) \text{ for } v(A \Rightarrow B), \quad (3.21)$$

and

$$\neg v(A) \text{ for } v(\text{not } A), \quad (3.22)$$

with the understanding that  $\wedge$ ,  $\vee$  and  $\neg$  reduce to Min (conjunction), Max (disjunction) and 1-operations when  $v(A)$  and  $v(B)$  are points in  $[0,1]$ .

Now if  $v(A)$  and  $v(B)$  are linguistic truth-values expressed as

$$v(A) = \alpha_1/v_1 + \dots + \alpha_n/v_n \quad (3.23)$$

$$v(B) = \beta_1/w_1 + \dots + \beta_m/w_m. \quad (3.24)$$

where the  $v_i$  and  $w_j$  are points in  $[0,1]$  and the  $\alpha_i$  and  $\beta_j$  are their respective grades of membership in  $A$  and  $B$ , then by applying the extension principle to  $v(A \text{ and } B)$ , we obtain

$$\begin{aligned} v(A \text{ and } B) &= v(A) \wedge v(B) \\ &= (\alpha_1/v_1 + \dots + \alpha_n/v_n) \wedge (\beta_1/w_1 + \dots + \beta_m/w_m) \\ &= \sum_{i,j} (\alpha_i \wedge \beta_j) / (v_i \wedge w_j). \end{aligned} \quad (3.25)$$

Thus, the truth-value of  $A$  and  $B$  is a fuzzy subset of  $[0,1]$  whose support comprises the points  $v_i \wedge w_j, i=1, \dots, n, j=1, \dots, m$  with respective grades of membership  $(\alpha_i \wedge \beta_j)$ . Note that (3.25) is equivalent to the expression (3.107) of Part I for the membership function of the intersection of fuzzy sets having fuzzy membership functions.

**Example 3.2.** Suppose that

$$\begin{aligned} v(A) &= \text{true} \\ &= 0.5/0.7 + 0.7/0.8 + 0.9/0.9 + 1/1 \end{aligned} \quad (3.26)$$

and

$$\begin{aligned}
 v(B) &= \text{not true} \\
 &= 1/0 + 1/0.1 + 1/0.2 + 1/0.3 + 1/0.4 + 1/0.5 \\
 &\quad + 1/0.6 + 0.5/0.7 + 0.3/0.8 + 0.1/0.9. \quad (3.27)
 \end{aligned}$$

Then the use of (3.25) leads to

$$\begin{aligned}
 v(A \text{ and } B) &= \text{true} \wedge \text{not true} \\
 &= 1/(0 + 0.1 + 0.2 + 0.3 + 0.4 + 0.5 + 0.6) \\
 &\quad + 0.5/0.7 + 0.3/0.8 + 0.1/0.9 \\
 &= \text{not true}. \quad (3.28)
 \end{aligned}$$

In a similar fashion, for the truth-value of  $A$  or  $B$ , we obtain

$$\begin{aligned}
 v(A \text{ or } B) &= v(A) \vee v(B) \\
 &= (\alpha_1/v_1 + \dots + \alpha_n/v_n) \vee (\beta_1/w_1 + \dots + \beta_m/w_m) \\
 &= \sum_{i,j} (\alpha_i \wedge \beta_j) / (v_i \vee w_j). \quad (3.29)
 \end{aligned}$$

The truth-value of  $A \Rightarrow B$  depends on the manner in which the connective  $\Rightarrow$  is defined for numerical truth-values. Thus, if we define [see Part I, Eq. (2.24)]

$$v(A \Rightarrow B) = \neg v(A) \vee v(A) \wedge v(B) \quad (3.30)$$

for the case where  $v(A)$  and  $v(B)$  are points in  $[0,1]$ , then the application of the extension principle yields (see Part I, Comment 3.5)

$$\begin{aligned}
 v(A \Rightarrow B) &= [(\alpha_1/v_1 + \dots + \alpha_n/v_n) \\
 &\quad \Rightarrow (\beta_1/w_1 + \dots + \beta_m/w_m)] \\
 &= \sum_{i,j} (\alpha_i \wedge \beta_j) / (1 - v_i) \vee (v_i \wedge w_j) \quad (3.31)
 \end{aligned}$$

for the case where  $v(A)$  and  $v(B)$  are fuzzy subsets of  $[0,1]$ .

Comment 3.3. It is important to have a clear understanding of the difference between *and* in, say, *true and not true*, and  $\wedge$  in *true  $\wedge$  not true*. In the former, our concern is with the meaning of

the term *true and not true*, and *and* is defined by the relation

$$M(\text{true and not true}) = M(\text{true}) \cap M(\text{not true}), \quad (3.32)$$

where  $M$  is the function mapping a term into its meaning (see Definition 2.1). By contrast, in the case of *true  $\wedge$  not true* we are concerned with the truth-value of *true  $\wedge$  not true*, which is derived from the equivalence [see (3.19)]

$$v(A \text{ and } B) = v(A) \wedge v(B). \quad (3.33)$$

Thus, in (3.32)  $\cap$  is the operation of intersection of fuzzy sets, whereas in (3.33),  $\wedge$  is that of conjunction. To illustrate the difference by a simple example, let  $V = 0 + 0.1 + \dots + 1$ , and let  $P$  and  $Q$  be fuzzy subsets of  $V$  defined by

$$P = 0.5/0.3 + 0.8/0.7 + 0.6/1, \quad (3.34)$$

$$Q = 0.1/0.3 + 0.6/0.7 + 1/1. \quad (3.35)$$

Then

$$P \cap Q = 0.1/0.3 + 0.6/0.7 + 0.6/1, \quad (3.36)$$

whereas

$$P \wedge Q = 0.5/0.3 + 0.8/0.7 + 0.6/1. \quad (3.37)$$

Note that the same issue arises in the case of *not* and  $\neg$ , as pointed out in Comment 3.1.

Comment 3.4. It should be noted that in applying the extension principle [Part I, Eq. (3.96)] to the computation of  $v(A \text{ and } B)$ ,  $v(A \text{ or } B)$  and  $v(A \Rightarrow B)$ , we are tacitly assuming that  $v(A)$  and  $v(B)$  are noninteractive fuzzy variables in the sense of Part I, Comment 3.5. If  $v(A)$  and  $v(B)$  are interactive, then it is necessary to apply the extension principle as expressed by (3.97) of Part I rather than (3.96). It is of interest to observe that the issue of possible interaction between  $v(A)$  and  $v(B)$  arises even when  $v(A)$  and  $v(B)$  are points in  $[0,1]$  rather than



fuzzy variables.

Comment 3.5. By employing the extension principle to define the operations  $\wedge$ ,  $\vee$ ,  $\neg$  and  $\Rightarrow$  on linguistic truth-values, we are in effect treating fuzzy logic as an extension of multivalued logic. In the same sense, the classical three-valued logic may be viewed as an extension of two-valued logic [see Eqs. (3.64) *et seq.*].

The expressions for  $v(\text{not } A)$ ,  $v(A \text{ and } B)$ ,  $v(A \text{ or } B)$  and  $v(A \Rightarrow B)$  given above become more transparent if we first decompose  $v(A)$  and  $v(B)$  into level-sets and then apply the level-set form of the extension principle [see (3.86)] to the operations  $\neg$ ,  $\wedge$ ,  $\vee$ , and  $\Rightarrow$ . In this way, we are led to a simple graphical rule for computing the truth-values in question (see Fig. 14). Specifically, let the intervals  $[a_1, a_2]$  and  $[b_1, b_2]$  be the  $\alpha$ -level sets for  $v(A)$  and  $v(B)$ . Then, by using the extensions of the operations  $\neg$ ,  $\wedge$  and  $\vee$  to intervals, namely [see Part I, Eq. (3.100)]

$$\neg(a_1, a_2) = [1 - a_2, 1 - a_1], \quad (3.38)$$

$$[a_1, a_2] \wedge [b_1, b_2] = [a_1 \wedge b_1, a_2 \wedge b_2], \quad (3.39)$$

$$[a_1, a_2] \vee [b_1, b_2] = [a_1 \vee b_1, a_2 \vee b_2], \quad (3.40)$$

we can find by inspection the  $\alpha$ -level-sets for  $v(\text{not } A)$ ,  $v(A \text{ and } B)$  and  $v(A \text{ or } B)$ . Having found these level-sets,  $v(\text{not } A)$ ,  $v(A \text{ and } B)$  and  $v(A \text{ or } B)$  can readily be determined by varying  $\alpha$  from 0 to 1.

As a simple illustration, consider the determination of the conjunction of linguistic truth-values  $v(A) \underline{\Delta} \text{true}$  and  $v(B) \underline{\Delta} \text{false}$ , with the membership functions of *true* and *false* having

the form shown in Fig. 15.

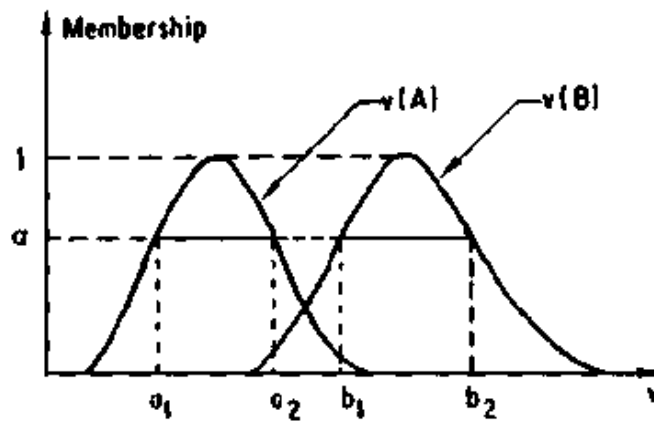

Fig. 14. Level-sets of truth-values of  $A$  and  $B$ .

We observe that, for all values of  $\alpha$ ,

$$[a_1, a_2] \wedge [b_1, b_2] = [b_1, b_2], \quad (3.41)$$

which implies that [see Part I, Eq. (3.118)]

$$[b_1, b_2] \leq [a_1, a_2] \quad (3.42)$$

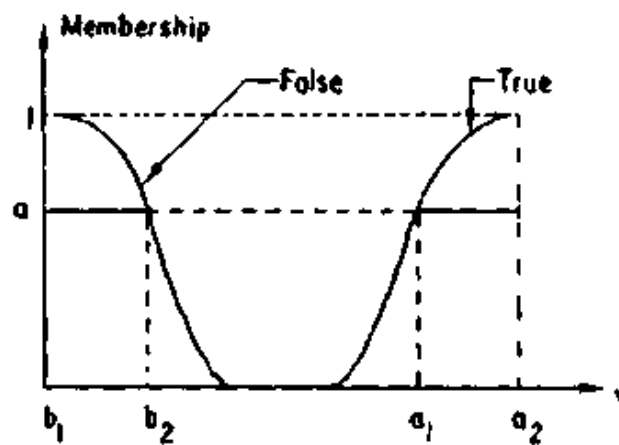

Fig. 15. Computation of the truth-value of the conjunction of *true* and *false*.

Consequently, merely on the basis of the form of the membership functions of *true* and *false*, we can conclude that

$$true \wedge false = false, \quad (3.43)$$

which is consistent with (3.25).

*Truth tables and linguistic approximation*

In two-valued, three-valued and, more generally,  $n$ -valued logics the binary connectives  $\wedge$ ,  $\vee$  and  $\Rightarrow$  are usually defined by a tabulation of the truth-values of  $A$  and  $B$ ,  $A$  or  $B$  and  $A \Rightarrow B$  in terms of the truth-values of  $A$  and  $B$ .

Since in a fuzzy logic the number of truth-values is, in general, infinite,  $\wedge$ ,  $\vee$  and  $\Rightarrow$  cannot be defined by tabulation. However, it may be desirable to tabulate say,  $\wedge$ , for a finite set of truth-values of interest, e. g., *true*, *not true*, *false*, *very true*, *very(not true)*, *more or less true*, etc. In such a table, for the entry in the  $i$ th row (say *not true*) and in the  $j$ th column (say *more or less true*), the  $(i, j)$  th entry would be

$$(i, j) \text{th entry} = i \text{th row label } (\underline{\Delta} \text{not true}) \wedge j \text{th column label} \\ (\underline{\Delta} \text{more or less true}). \quad (3.44)$$

Given the definition of the primary term *true* and the definitions of the modifiers *not* and *more or less*, we can compute the right-hand side of (3.44), that is,

$$not \ true \ \wedge \ more \ or \ less \ true \quad (3.45)$$

by using (3.25). However, the problem is that in most instances the result of the computation would be a fuzzy subset of the universe of truth-values which may not correspond to any of the truth-values in the term-set of *Truth*. Thus, if we wish to have a truth table in which the entries are linguistic, we must be content with an approximation to the exact truth-value of  $(i \text{th row label} \wedge j \text{th column label})$ . Such an approximation will be referred to as a *linguistic approximation*. (See Part I, Fig. 5.)

As an illustration, suppose that the universe of truth-values is expressed as

$$V = 0 + 0.1 + 0.2 + \dots + 1, \quad (3.46)$$

and that

$$\text{true} = 0.7/0.8 + 1/0.9 + 1/1, \quad (3.47)$$

$$\text{more or less true} = 0.5/0.6 + 0.7/0.7 + 1/0.8 + 1/0.9 + 1/1 \quad (3.48)$$

and

$$\text{almost true} = 0.6/0.8 + 1/0.9 + 0.6/1. \quad (3.49)$$

In the truth-table for  $V$ , assume that the  $i$ th row label is *more or less true* and the  $j$ th column label is *almost true*. Then, for the  $(i, j)$ th entry in the table, we have

$$\begin{aligned} \text{more or less true} \vee \text{almost true} &= (0.5/0.6 + 0.7/0.7 + 1/0.8 \\ &\quad + 1/0.9 + 1/1) \vee (0.6/0.8 \\ &\quad + 1/0.9 + 0.6/1) \\ &= 0.6/0.8 + 1/0.9 + 1/1. \end{aligned} \quad (3.50)$$

Now, we observe that the right-hand side of (3.50) is approximately equal to *true* as defined by (3.47). Consequently, in the truth table for  $V$ , a linguistic approximation to the  $(i, j)$ th entry would be *true*.

#### *The truth-values unknown and undefined*

Among the truth-values that can be associated with the linguistic variable *Truth*, there are two that warrant special attention, namely, the empty set  $\theta$  and the unit interval  $[0, 1]$ —which correspond to the least and greatest elements (under set inclusion) of the lattice of fuzzy subsets of  $[0, 1]$ . The importance of these particular truth-values stems from their interpretability

as the truth-values *undefined* and *unknown*,<sup>①</sup> respectively. For convenience we shall denote these truth-values by  $\theta$  and  $?$ , with the understanding that  $\theta$  and  $?$  are defined by

$$\theta \triangleq \int_0^1 0/v \quad (3.51)$$

and

$$\begin{aligned} ? &\triangleq V = \text{universe of truth-values} \\ &= [0, 1] \\ &= \int_0^1 0/w. \end{aligned} \quad (3.52)$$

Interpreted as grades of membership, *undefined* and *unknown* enter also in the representation of fuzzy sets of type 1. For such sets, the grade of membership of a point  $u$  in  $U$  may have one of three possible forms: (i) a number in the interval  $[0, 1]$ ; (ii)  $\theta$  (*undefined*); and (iii)  $?$  (*unknown*). As a simple example, let

$$U = a + b + c + d + e \quad (3.53)$$

and consider a fuzzy subset of  $U$  represented as

$$A = 0.1a + 0.9b + ?c + \theta d. \quad (3.54)$$

In this case, the grade of membership of  $c$  in  $A$  is *unknown* and that of  $d$  is *undefined*. More generally, we may have

$$A = 0.1a + 0.9b + 0.8?c + \theta d, \quad (3.55)$$

meaning that the grade of membership of  $c$  in  $A$  is *partially unknown*, with  $0.8?c$  interpreted as

---

① The concept of *unknown* is related to that of *don't care* in the context of switching circuits [44]. Another related concept is that of quasi-truth-functionality [46].

$$0.8? \ c \triangleq \left( \int_0^1 0.8/v \right) / c. \quad (3.56)$$

It is important to have a clear understanding of the difference between 0 and  $\theta$ . When we say that the grade of membership of a point  $u$  in  $A$  is  $\theta$ , what we mean is that the membership function  $\mu_A : U \rightarrow [0, 1]$  is undefined at  $u$ . For example, suppose that  $U$  is the set of real numbers and  $\mu_A$  is a function defined on integers, with  $\mu_A(u) = 1$  if  $u$  is an even integer and  $\mu_A(u) = 0$  if  $u$  is an odd integer. Then the grade of membership of  $u = 1.5$  in  $A$  is  $\theta$  rather than 0. On the other hand, if  $\mu_A$  were defined on real numbers and  $\mu_A(u) = 1$  iff  $u$  is even, then the grade of membership of 1.5 in  $A$  would be 0.

Since we know how to compute the truth-values of  $A$  and  $B$ ,  $A$  or  $B$  and  $\text{not } B$  given the linguistic truth-values of  $A$  and  $B$ , it is a simple matter to compute  $v(A \text{ and } B)$ ,  $v(A \text{ or } B)$  and  $v(\text{not } B)$  when  $v(B) = ?$ . Thus, suppose that

$$v(A) = \int_0^1 \mu(v)/v \quad (3.57)$$

and

$$v(B) = ? = \int_0^1 1/w. \quad (3.58)$$

By applying the extension principle, as in (3.25), we obtain

$$\begin{aligned} v(A) \wedge ? &= \int_0^1 \mu(v)/v \wedge \int_0^1 1/w \\ &= \int_0^1 \int_0^1 \mu(v)/(v \wedge w), \end{aligned} \quad (3.59)$$

where

$$\int_0^1 \int_0^1 \Delta \equiv \int_{[0,1] \times [0,1]}, \quad (3.60)$$

and which upon simplification reduces to

$$v(A) \wedge ? = \int_0^1 [V_{[w,1]} \mu(v)] / w. \quad (3.61)$$

In other words, the truth-value of  $A$  and  $B$ , where  $v(B) = \text{unknown}$  is a fuzzy subset of  $[0, 1]$  in which the grade of membership of a point  $w$  is given by the supremum of  $\mu(v)$  (membership function of  $A$ ) over the interval  $[w, 1]$ .

In a similar fashion, the truth-value of  $A$  or  $B$  is found to be expressed by

$$\begin{aligned} v(A \text{ or } B) &= \int_0^1 \int_0^1 \mu(v) / (v \vee w) \\ &= \int_0^1 [V_{[0,w]} \mu(v)] / w. \end{aligned} \quad (3.62)$$

It should be noted that both (3.61) and (3.62) can readily be obtained by the graphical procedure described earlier [see (3.38) *et seq.*]. An example illustrating its application is shown in Fig. 16.

Turning to the case where  $v(B) = \theta$ , we find

$$\begin{aligned} v(A) \wedge \theta &= \int_0^1 \int_0^1 0 / (v \wedge w) \\ &= \int_0^1 0 / w \\ &= \theta \end{aligned} \quad (3.63)$$

and likewise for  $v(A) \vee \theta$ .

It is instructive to examine what happens to the above

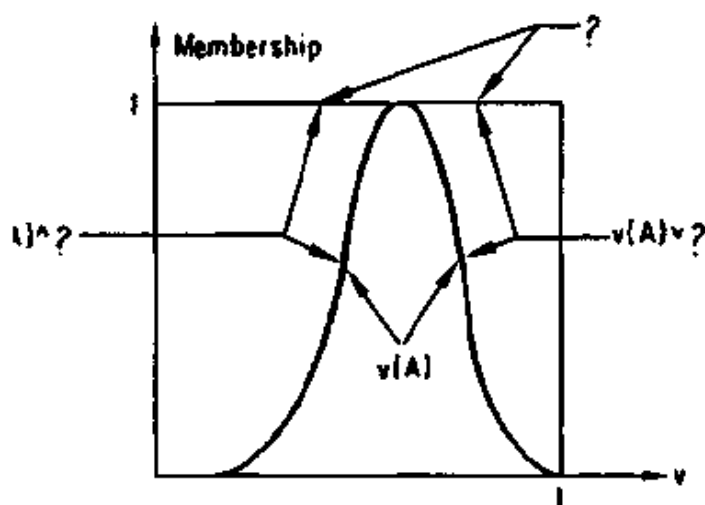

Fig. 16. Conjunction and disjunction of the truth-value of  $A$  with the truth-value *unknown* ( $\underline{\Delta}?$ ).

relations when we apply them to the special case of two-valued logic, that is, to the case where the universe  $V$  is of the form

$$V = 0 + 1, \quad (3.64)$$

or, expressed more conventionally,

$$V = T + F, \quad (3.65)$$

where  $T$  stands for *true* and  $F$  stands for *false*. Since  $?$  is  $V$ , we can identify the truth-value *unknown* with *true or false*, that is,

$$? = T + F \quad (3.66)$$

The resulting logic has four truth-values;  $\theta$ ,  $T$ ,  $F$  and  $T + F$  ( $\underline{\Delta}?$ ), and is an extension of two-valued logic in the sense of Comment 3.5.

Since the universe of truth-values has only two elements, it is expedient to derive the truth tables for  $\vee$ ,  $\wedge$  and  $\Rightarrow$  in this four-valued logic directly rather than through specialization of the general formulae (3.25), (3.29) and (3.31). Thus, by



applying the extension principle to  $\wedge$ , we find at once

$$T \wedge \theta = \theta, \quad (3.67)$$

$$T \wedge (T+F) = T \wedge T + T \wedge F = T+F, \quad (3.68)$$

$$\begin{aligned} F \wedge (T+F) &= F \wedge T + F \wedge T \\ &= F+F \\ &= F, \end{aligned} \quad (3.69)$$

$$\begin{aligned} (T+F) \wedge (T+F) &= T \wedge T + T \wedge F + F \wedge T + F \wedge F \\ &= T+F+F+F \\ &= T+F, \end{aligned} \quad (3.70)$$

and consequently the extended truth-table for  $\wedge$  has the form shown in Table 1.

**Table 1**

$\wedge$	$\theta$	$T$	$F$	$T+F$
$\theta$	$\theta$	$\theta$	$\theta$	$\theta$
$T$	$\theta$	$T$	$F$	$T+F$
$F$	$\theta$	$F$	$F$	$F$
$T+F$	$\theta$	$T+F$	$F$	$T+F$

Upon suppression of the entry  $\theta$ , this reads as shown in Table 2.

**Table 2**

$\wedge$	$T$	$F$	$T+F$
$T$	$T$	$F$	$T+F$
$F$	$F$	$F$	$F$
$T+F$	$T+F$	$F$	$T+F$

Similarly, for the operation  $\vee$  we obtain Table 3.

**Table 3**

V	T	F	T+F
T	T	T	T
F	T	F	T+F
T+F	T	T+F	T+F

These tables agree — as they should — with the corresponding truth tables for  $\wedge$  and  $\vee$  in conventional three-valued logic [46].

The approach employed above provides some insight into the definition of  $\Rightarrow$  in two-valued logic — a somewhat controversial issue which motivated the development of modal logic [45, 47]. Specifically, instead of defining  $\Rightarrow$  in the conventional fashion, we may define  $\Rightarrow$  as a connective in three-valued logic by the partial truth table in Table 4,

**Table 4**

$\Rightarrow$	T	F	T+F
T	T	F	
F			T

which expresses the intuitively reasonable idea that if  $A \Rightarrow B$  is *true* and  $A$  is *false*, then the truth-value of  $B$  is *unknown*. Now we can raise the question; How should the blank entries in the above table be filled in order to yield the entry  $T$  in the (2, 3) position in Table 4 upon the application of the extension principle? Thus, denoting the unknown entries in positions (2, 1) and (2, 2) by  $x$  and  $y$ , respectively, we must have

$$\begin{aligned}
 F \Rightarrow (T+F) &= (F \Rightarrow T) + (F \Rightarrow F) \\
 &= x + y \\
 &= T,
 \end{aligned}
 \tag{3.71}$$

which necessitates that

$$x=y=T. \quad (3.72)$$

In this way, we are led to the conventional definition of  $\Rightarrow$  in two-valued logic, which is expressed by the truth table

$\Rightarrow$	$T$	$F$
$T$	$T$	$F$
$F$	$T$	$T$

As the above example demonstrates, the notion of the *unknown* truth-value in conjunction with the extension principle helps to clarify some of the concepts and relations in the conventional two-valued and three-valued logics. These logics may be viewed, of course, as degenerate cases of a fuzzy logic in which the truth-value *unknown* is the entire unit interval rather than the set  $0+1$ .

#### *Composite truth variables and truth-value distributions*

In the foregoing discussion, we have limited our attention to linguistic truth variables which are unary variables in the sense of Part 1, Definition 2.1. In the following, we shall define the concept of a *composite* truth variable and dwell briefly on some of its implications.

Thus, let

$$\mathcal{F} \triangleq (\mathcal{F}_1, \dots, \mathcal{F}_n) \quad (3.73)$$

denote an  $n$ -ary composite linguistic truth variable in which each  $\mathcal{F}_i, i=1, \dots, n$ , is a unary linguistic truth variable associated with a term-set  $T_i$ , a universe of discourse  $V_i$ , and a base variable  $v_i$  (see Definition 2.1). For simplicity, we shall sometimes

employ the symbol  $\mathcal{F}_i$ , in the dual role of (a) the name of the  $i$ th variable in (3.73), and (b) a generic name for the truth-values of  $\mathcal{F}_i$ . Furthermore, we shall assume that  $T_1 = T_2 = \dots = T_n$  and  $V_1 = V_2 = \dots = V_n = [0, 1]$ .

Viewed as a composite variable whose component variables  $\mathcal{F}_1, \dots, \mathcal{F}_n$  take values in their respective universes  $T_1, \dots, T_n$ ,  $\mathcal{F}$  is an  $n$ -ary nonfuzzy variable [see Part I, Eq. (2.3) *et seq.*]. Thus, the restriction  $R(\mathcal{F})$  imposed by  $\mathcal{F}$  is an  $n$ -ary nonfuzzy relation in  $T_1 \times \dots \times T_n$  which may be represented as an unordered list of ordered  $n$ -tuples of the form

$$\begin{aligned} R(\mathcal{F}) = & (\text{true}, \text{very true}, \text{false}, \dots, \text{quite true}) \\ & + (\text{quite true}, \text{true}, \text{very true}, \dots, \text{very true}) \\ & + (\text{true}, \text{true}, \text{more or less true}, \dots, \text{true}) \\ & + \dots \end{aligned} \quad (3.74)$$

The  $n$ -tuples in  $R(\mathcal{F})$  will be referred to as *truth-value assignment lists* since each such  $n$ -tuple may be interpreted as an assignment of truth-values to a list of propositions  $A_1, \dots, A_n$ , with

$$A \triangleq (A_1, \dots, A_n) \quad (3.75)$$

representing a composite proposition. For example, if

$A \triangleq (\text{Scott is tall}, \text{Pat is dark-haired}, \text{Tina is very pretty})$ , then a triple in  $R(\mathcal{F})$  of the form  $(\text{very true}, \text{true}, \text{very true})$  would represent the following truth-value assignments:

$$v(\text{Scott is tall}) = \text{very true}, \quad (3.76)$$

$$v(\text{Pat is dark-haired}) = \text{true}, \quad (3.77)$$

$$v(\text{Tina is very pretty}) = \text{very true}. \quad (3.78)$$

Based on this interpretation of the  $n$ -tuples in  $R(\mathcal{F})$ , we

shall frequently refer to  $R(\mathcal{F})$  as a *truth-value distribution*. Correspondingly, the restriction  $R(\mathcal{F}_{i_1}, \dots, \mathcal{F}_{i_k})$  which is imposed by the  $k$ -ary variable  $(\mathcal{F}_{i_1}, \dots, \mathcal{F}_{i_k})$ , where  $q = (i_1, \dots, i_k)$  is a subsequence of the index sequence  $(1, \dots, n)$ , will be referred to as a *marginal truth-value distribution induced by  $R(\mathcal{F}_1, \dots, \mathcal{F}_n)$*  [see Part I, Eq. (2.8)]. Then, using the notation employed in Part I, Sec. 2 (see also Note 1.1 in this Part), the relation between  $R(\mathcal{F}_{i_1}, \dots, \mathcal{F}_{i_k})$  and  $R(\mathcal{F}_1, \dots, \mathcal{F}_n)$  may be expressed compactly as

$$R(\mathcal{F}_{(q)}) = P_q R(\mathcal{F}), \quad (3.79)$$

where  $P_q$  denotes the operation of projection on the Cartesian product  $T_{i_1} \times \dots \times T_{i_k}$

Example 3.1. Suppose that  $R(\mathcal{F})$  is expressed by

$$\begin{aligned} R(\mathcal{F}) &\triangleq R(\mathcal{F}_1, \mathcal{F}_2, \mathcal{F}_3) \\ &= (\text{true}, \text{quite true}, \text{very true}) \\ &\quad + (\text{very true}, \text{true}, \text{very very true}) \\ &\quad + (\text{true}, \text{false}, \text{quite true}) \\ &\quad + (\text{false}, \text{false}, \text{very true}). \end{aligned} \quad (3.80)$$

To obtain  $R(\mathcal{F}_1, \mathcal{F}_2)$  we delete the  $\mathcal{F}_3$  component in each triple, yielding

$$\begin{aligned} R(\mathcal{F}_1, \mathcal{F}_2) &= (\text{true}, \text{quite true}) + (\text{very true}, \text{true}) \\ &\quad + (\text{true}, \text{false}) + (\text{false}, \text{false}). \end{aligned} \quad (3.81)$$

Similarly, by deleting the  $\mathcal{F}_2$  components in  $R(\mathcal{F}_1, \mathcal{F}_2)$ , we obtain

$$R(\mathcal{F}_1) = \text{true} + \text{very true} + \text{false}. \quad (3.82)$$

If we view  $\mathcal{F}$  as an  $n$ -ary nonfuzzy variable whose values are linguistic truth-values, the definition of noninteraction (Part

1, Definition 2.2) assumes the following form in the case of linguistic truth variables.

Definition 3.1. The components of an  $n$ -ary linguistic truth variable  $\mathcal{F} = (\mathcal{F}_1, \dots, \mathcal{F}_n)$  are  $\lambda$ -noninteractive ( $\lambda$  standing for linguistic) iff the truth-value distribution  $R(\mathcal{F}_1, \dots, \mathcal{F}_n)$  is separable in the sense that

$$R(\mathcal{F}_1, \dots, \mathcal{F}_n) = R(\mathcal{F}_1) \times \dots \times R(\mathcal{F}_n). \quad (3.83)$$

The implication of this definition is that, if  $\mathcal{F}_1, \dots, \mathcal{F}_n$  are  $\lambda$ -noninteractive, then the assignment of specific linguistic truth-values to  $\mathcal{F}_1, \dots, \mathcal{F}_k$  does not affect the truth-values that can be assigned to the complementary components in  $(\mathcal{F}_1, \dots, \mathcal{F}_n)$   $\mathcal{F}_{k+1}, \dots, \mathcal{F}_m$ .

Before proceeding to illustrate the concept of  $\lambda$ -noninteraction by examples, we shall define another type of noninteraction which will be referred to as  $\beta$ -noninteraction ( $\beta$  standing for base variable).

Definition 3.2. The components of an  $n$ -ary linguistic truth variable  $\mathcal{F} = (\mathcal{F}_1, \dots, \mathcal{F}_n)$  are  $\beta$ -noninteractive iff their respective base variables  $v_1, \dots, v_n$  are noninteractive in the sense of Part 1, Definition 2.2; that is, the  $v_i$  are not jointly constrained.

To illustrate the concepts of noninteraction defined above we shall consider a few simple examples.

Example 3.2. For the truth-value distribution of Example 3.1, we have

$$\begin{aligned} R(\mathcal{F}_1) &= \text{true} + \text{very true} - \text{false}, \\ R(\mathcal{F}_2) &= \text{quite true} + \text{true} + \text{false}, \\ R(\mathcal{F}_3) &= \text{very true} + \text{very very true} + \text{quite true}, \end{aligned} \quad (3.84)$$

and thus

$$\begin{aligned}
 R(\mathcal{F}_1) \times R(\mathcal{F}_2) \times R(\mathcal{F}_3) &= (\text{true}, \text{quite true}, \text{very true}) \\
 &\quad + (\text{very true}, \text{quite true}, \text{very true}) \cdots + (\text{false}, \text{false}, \text{quite true}) \neq R(\mathcal{F}_1, \mathcal{F}_2, \mathcal{F}_3),
 \end{aligned}
 \tag{3.85}$$

which implies that  $R(\mathcal{F}_1, \mathcal{F}_2, \mathcal{F}_3)$  is not separable and hence  $\mathcal{F}_1, \mathcal{F}_2, \mathcal{F}_3$  are  $\lambda$ -interactive.

**Example 3.3.** Consider a composite proposition of the form  $(A, \text{not } A)$  and assume for simplicity that  $T(\mathcal{F}) = \text{true} + \text{false}$ . In view of (3.11), if the truth-value of  $A$  is *true* then that of *not A* is *false*, and vice versa. Consequently, the truth-value distribution for the propositions in question must be of the form

$$R(\mathcal{F}_1, \mathcal{F}_2) = (\text{true}, \text{false}) + (\text{false}, \text{true}), \tag{3.86}$$

which induces

$$R(\mathcal{F}_1) = R(\mathcal{F}_2) = \text{true} + \text{false}. \tag{3.87}$$

Now

$$\begin{aligned}
 R(\mathcal{F}_1) \times R(\mathcal{F}_2) &= (\text{true} + \text{false}) \times (\text{true} + \text{false}) \\
 &= (\text{true}, \text{true}) + (\text{true}, \text{false}) \\
 &\quad + (\text{false}, \text{true}) + (\text{false}, \text{false}),
 \end{aligned}
 \tag{3.88}$$

and since

$$R(\mathcal{F}_1, \mathcal{F}_2) \neq R(\mathcal{F}_1) \times R(\mathcal{F}_2)$$

it follows that  $\mathcal{F}_1$  and  $\mathcal{F}_2$  are  $\lambda$ -interactive.

**Example 3.4.** The above example can also be used as an illustration of  $\beta$ -interaction. Specifically, regardless of the truth-values assigned to  $A$  and *not A*, it follows from the definition of *not* [see Part 1, Eq. (3.33)] that the base variables  $v_1$  and  $v_2$  are

constrained by the equation

$$v_1 + v_2 = 1. \quad (3.89)$$

In other words, in the case of a composite proposition of the form  $(A, \text{not } A)$ , the sum of the numerical truth-values of  $A$  and  $\text{not } A$  must be unity.

Remark 3.1. It should be noted that, in Example 3.4,  $\beta$ -interaction is a consequence of  $A_2$  being related to  $A_1$  by negation. In general, however,  $\mathcal{F}_1, \dots, \mathcal{F}_n$  may be  $\lambda$ -interactive without being  $\beta$ -interactive.

A useful application of the concept of interaction relates to the truth-value *unknown* [see (3.52)]. Specifically, assuming for simplicity that  $V = T + F$ , suppose that

$$A_1 \triangleq \text{Pat lives in Berkeley}, \quad (3.90)$$

$$A_2 \triangleq \text{Pat lives in San Francisco}, \quad (3.91)$$

with the understanding that one and only one of these statements is true. This implies that, although the truth-values of  $A_1$  and  $A_2$  are *unknown* ( $\triangleq ? = T + F$ ), that is,

$$\begin{aligned} v(A_1) &= T + F, \\ v(A_2) &= T + F, \end{aligned} \quad (3.92)$$

they are constrained by the relations

$$v(A_1) \vee v(A_2) = T, \quad (3.93)$$

$$v(A_1) \wedge v(A_2) = F. \quad (3.94)$$

Equivalently, the truth-value distribution associated with (3.90) and (3.91) may be regarded as the solution of the equations

$$v(A_1) \vee v(A_2) = T, \quad (3.95)$$

$$v(A_1) \wedge v(A_2) = F, \quad (3.96)$$

which is



$$R(\mathcal{F}_1, \mathcal{F}_2) = (T, F) + (F, T). \quad (3.97)$$

Note that (3.97) implies

$$v(A_1) = R(\mathcal{F}_1) = T + F \quad (3.98)$$

and

$$v(A_2) = R(\mathcal{F}_2) = T + F, \quad (3.99)$$

in agreement with (3.92). Note also that  $\mathcal{F}_1$  and  $\mathcal{F}_2$  are  $\beta$ -interactive in the sense of Definition 3.2, with  $V = T + F$ .

Now if  $A_1$  and  $A_2$  were changed to

$$A_1 \triangleq \text{Pat lived in Berkeley}, \quad (3.100)$$

$$A_2 \triangleq \text{Pat lived in San Francisco}, \quad (3.101)$$

with the possibility that both  $A_1$  and  $A_2$  could be true, then we would still have

$$v(A_1) = ? = T + F, \quad (3.102)$$

$$v(A_2) = ? = T + F, \quad (3.103)$$

but the constraint equation would become

$$v(A_1) \vee v(A_2) = T. \quad (3.104)$$

In this case, the truth-value distribution is the solution of (3.104), which is given by

$$R(\mathcal{F}_1, \mathcal{F}_2) = (\text{true}, \text{true}) + (\text{true}, \text{false}) + (\text{false}, \text{true}). \quad (3.105)$$

An important observation that should be made in connection with the above examples is that in some cases a truth-value distribution may be given in an implicit form, e. g., as a solution of a set of truth-value equations, rather than as an explicit list of ordered  $n$ -tuples of truth-values. In general, this will be the case where linguistic truth-values are assigned not to each  $A_i$  in  $A =$

$(A_1, \dots, A_n)$ , but to Boolean expressions involving two or more of the components of  $A$ .

Another point that should be noted is that truth-value distributions may be nested. As a simple illustration, in the case of a unary proposition we may have a nested sequence of assertions of the form

$$\text{““Vera is very very intelligent” is very true” is true.} \quad (3.106)$$

Restrictions induced by assertions of this type may be computed as follows..

Let the base variable in (3.106) be IQ, and let  $R_0(\text{IQ})$  denote the restriction on the IQ of Vera. Then the proposition “Vera is very very intelligent” implies that

$$R_0(\text{IQ}) = \text{very very intelligent.} \quad (3.107)$$

Now, the proposition “Vera is very very intelligent” is very true” implies that the grade of membership of Vera in the fuzzy set  $R_0(\text{IQ})$  is very true [see (3.6)]. Let  $\mu_{\text{very true}}$  denote the membership function of very true [see (3.17)], and let  $\mu_{R_0}$  denote that of  $R_0(\text{IQ})$ . Regarding  $\mu_{R_0}$  as a relation from the range of IQ to  $[0,1]$ , let  $\mu_{R_0}^{-1}$  denote the inverse relation from  $[0,1]$  to the range of IQ. This relation, then, induces a fuzzy set  $R_1(\text{IQ})$  expressed by

$$R_1(\text{IQ}) = \mu_{R_0}^{-1}(\text{very true}), \quad (3.108)$$

which can be computed by the use of the extension principle in the form given in Part I, Eq. (3.80). The fuzzy set  $R_1(\text{IQ})$  represents the restriction on IQ induced by the assertion “Vera is very very intelligent” is very true.”

Continuing the same argument, the restriction on IQ

induced by the assertion ““Vera is *very very intelligent*” is *very true*” is *true*” may be expressed as

$$R_2(\text{IQ}) = \mu_{R_1}^{-1}(\text{true}), \quad (3.109)$$

where  $\mu_{R_1}^{-1}$  denotes the relation inverse to  $\mu_{R_1}$ , which is the membership function of  $R_1(\text{IQ})$  given by (3.108). In this way, we can compute the restriction induced by a nested sequence of assertions such as that exemplified by (3.106).

The basic idea behind the technique sketched above is that an assertion of the form “*u is A*” is *T*,” where *A* is a fuzzy predicate and *T* is a linguistic truth-value, modifies the restriction associated with *A* in accordance with the expression

$$A' = \mu_A^{-1}(T),$$

where  $\mu_A^{-1}$  is the inverse of the membership function of *A*, and *A'* is the restriction induced by the assertion “*u is A*” is *T*.”

## References

- [1] Sir William Thomson, *Popular Lectures and Addresses*, McMillan, London, 1891.
- [2] E. Feigenbaum, *Computers and Thought*, McGraw-Hill, New York, 1963.
- [3] M. Minsky and S. Papert, *Perceptrons: An Introduction to Computational Geometry*, M. I. T. Press, Cambridge, Mass., 1969.
- [4] M. Arbib, *The Metaphorical Brain*, Wiley-Interscience, New York, 1972.
- [5] A. Newell and H. Simon, *Human Problem Solving*, Prentice-Hall,

Englewood Cliffs, N. J. ,1972.

- [6] L. A. Zadeh, Fuzzy languages and their relation to human and machine intelligence, in *Proc. Int. Conf. on Man and Computer*, Bordeaux, France, S. Karger, Basel, 1972, pp.130~165.
- [7] L. A. Zadeh, Outline of a new approach to the analysis of complex systems and decision processes, *IEEE Trans. Syst. , Man and Cybern.*, SMC-3, 28~44(January 1973).
- [8] R. E. Bellman, R. E. Kalaba and L. A. Zadeh, Abstraction and pattern classification, *J. Math. Anal. Appl.* 13,1~7(1966).
- [9] M. Black, Reasoning with loose concepts, *Dialogue* 2,1~12(1963).
- [10] L. Wittgenstein, Logical form, *Proc. Aristotelian Soc.* 9, 162 ~ 171 (1929).
- [11] M. Scriven, The logic of criteria, *J. Philos.* 56, 857~868(1959).
- [12] H. Khatchadourian, Vagueness, meaning and absurdity, *Am. Phil. Quart.* 2,119~129(1965).
- [13] R. R. Verma, Vagueness and the principle of excluded middle, *Mind* 79,66~77(1970).
- [14] J. A. Goguen, The Logic of Inexact Concepts, *Synthese* 19,325 ~ 373 (1969).
- [15] E. Adams, The logic of "Almost All", *J. Philos. Logic* 3, 3 ~ 17 (1974).
- [16] K. Fine, Vagueness, truth and logic, Department of Philosophy, University of Edinburgh, 1973.
- [17] B. S. van Frassen, Presuppositions, supervaluations and free logic, in *The Logical Way of Doing Things* (K. Lambert, Ed. ), Yale U. P. , New Haven, Conn. , 1969.
- [18] G. Lakoff, Linguistics and natural logic, in *Semantics of Natural Languages*, (D. Davidson and G. Harman, Eds. ), D. Reidel, Dordrecht, The Netherlands, 1971.
- [19] L. A. Zadeh, Shadows of fuzzy sets, *Probl. Transfer Inf.* 2,37~44 (1966).

- [20] A. Kaufmann, *Theory of Fuzzy Sets*, Masson, Paris, 1972.
- [21] J. Goguen, *L-fuzzy sets*, *J. Math. Anal. Appl.* 18,145~174(1967).
- [22] J. G. Brown, A note on fuzzy sets, *Inf. Control* 18,32~39(1971).
- [23] M. Mizumoto, J. Toyoda and K. Tanaka, General formulation of formal grammars, *Inf. Sci.* 4,87~100,1972.
- [24] L. A. Zadeh, Similarity relations and fuzzy orderings, *Inf. Sci.* 3,177~200(1971).
- [25] R. E. Bellman and L. A. Zadeh, Decision-making in a fuzzy environment, *Manage. Sci.* 17,B-141-B-164(1970).
- [26] R. E. Bellman and M. Giertz, On the analytic formalism of the theory of fuzzy sets, *Inf. Sci.* 5,149~156(1973).
- [27] L. A. Zadeh, A fuzzy-set-theoretic interpretation of linguistic hedges, *J. Cybern.* 2,4~34(1972).
- [28] E. F. Codd, Relational completeness of data base sublanguages, in *Courant Computer Science Symposia*, Vol. 6, Prentice-Hall, Englewood Cliffs, N. J., 1971.
- [29] L. A. Zadeh, Fuzzy sets, *Inf. Control* 8, 338~353,1965.
- [30] A. Thomasian, *The Structure of Probability Theory With Applications*, McGraw-Hill, New York,1969.
- [31] R. E. Moore, *Interval Analysis*, Prentice-Hall, Englewood Cliffs, N. J., 1966.
- [32] J. A. Brzozowski, Regular expressions for linear sequential circuits, *IEEE Trans. Electron Comput.*, EC-14,148~156(1965).
- [33] E. Shamir, Algebraic, Rational and Context-Free Power Series in Noncommuting Variables, in M. Arbib's *Algebraic Theory of Machines, Languages and Semigroups*, Academic, New York, 1968, pp. 329~341.
- [34] A. Blikle, Equational languages, *Inf. Control* 21, 134~147(1972).
- [35] D. J. Rosenkrantz, Matrix equation and normal forms for context-free grammars, *J. Assoc. Comput. Mach.* 14,501~507,1967.
- [36] J. E. Hopcroft and J. D. Ullman, *Formal Languages and Their*

- Relations to Automata*, Addison-Wesley, Reading Mass. , 1969.
- [37] A. V. Aho and J. D. Ullman, *The Theory of Parsing, Translation and Compiling*, Prentice-Hall, Englewood Cliffs, N. J. ,1973.
- [38] G. Lakoff, Hedges: a study in meaning criteria and the logic of fuzzy concepts., in *Proc. 8th Reg. Meeting of Chic. Linguist. Soc.* , Univ. of Chicago Linguistics Dept. , April 1972.
- [39] L. A. Zadeh, Quantitative fuzzy semantics, *Inf. Sci.* 3, 159 ~ 176 (1971).
- [40] D. Knuth, Semantics of context-free languages, *Math. Syst. Theory*, 2,127~145(1968).
- [41] P. Lucas et al. , Method and notation for the formal definition of programming languages, Rept. TR 25. 087, IBM Laboratory, Vienna, 1968.
- [42] P. Wegner, The Vienna definition language, *ACM Comput. Surv.* 4.5 ~63,(1972).
- [43] J. A. Lee, *Computer Semantics*, Van Nostrand-Reinhold, New York, 1972.
- [44] Z. Kohavi, *Switching and Finite Automata Theory*, McGraw-Hill, New York, 1970.
- [45] G. E. Hughes and M. J. Cresswell, *An Introduction to Modal Logic*, Methuen, London, 1968.
- [46] N. Rescher, *Many-Valued Logic*, McGraw-Hill, New York, 1969.
- [47] R. Barkan, A functional calculus of first order based on strict implication, *J. Symbol. Logic* 11, 1~16(1946).
- [48] L. A. Zadeh, Probability measures of fuzzy events, *J. Math. Anal. Appl.* 23,421~427(1968).
- [49] A. DeLuca and S. Termini, A definition of non-probabilistic entropy in the setting of fuzzy set theory, *Inf. Control* 20,201~312(1972).
- [50] J. Hintikka and P. Suppes(Eds.), *Aspects of Inductive Logic*, North-Holland, Amsterdam, 1966.
- [51] T. Winograd, *Understanding Natural Language*, Academic, New

York, 1972.

- [52] A. DeLuca and S. Termini, Algebraic properties of fuzzy sets, *J. Math. Anal. Appl.* 40, 373~386(1972).
- [53] A. Rosenfeld, Fuzzy groups, *J. Math. Anal. Appl.* 35, 512~517 (1971).
- [54] L. A. Zadeh, Fuzzy Algorithms, *Inf. Control* 12, 94~102(1968).
- [55] E. Santos, Fuzzy algorithms, *Inf. Control* 17, 326~339(1970).
- [56] S. K. Chang, On the execution of fuzzy programs using finite state machines, *IEEE Trans. Electron. Comput.*, C-21,241~253(1972).
- [57] S. S. L. Chang and L. A. Zadeh, Fuzzy mapping and control, *IEEE Trans. Syst., Man and Cybern.*, SMC-2,30~34(1972).
- [58] E. T. Lee, Fuzzy languages and their relation to automata, Dissertation, Dept. of Electr. Eng. and Comput. Sci., Univ. of Calif., Berkeley, 1972.
- [59] R. C. T. Lee, Fuzzy logic and the resolution principle, *J. Assoc. Comput. Mach.* 19,109~119(1972).
- [60] K. M. Colby, S. Weber and F. D. Hill, Artificial paranoia, *J. Artif. Intell.* 2,1~25(1971).

## The Concept of a Linguistic Variable and its Application to Approximate Reasoning — III

### 1. Linguistic probabilities and averages over fuzzy sets

In the classical approach to probability theory, an *event*,  $A$ , is defined as a member of a  $\sigma$ -field,  $\mathcal{A}$ , of subsets of a sample space  $\Omega$ . Thus, if  $P$  is a normed measure over a measurable space  $(\Omega, \mathcal{A})$ , the probability of  $A$  is defined as  $P(A)$ , the measure of  $A$ , and is a number in the interval  $[0, 1]$ .

There are many real-world problems in which one or more of the basic assumptions which are implicit in the above definition are violated. First, the event,  $A$ , is frequently ill-defined, as in the question, "What is the probability that it will be a *warm day* tomorrow?" In this instance, the event *warm day* is a *fuzzy event* in the sense that there is no sharp dividing line between its occurrence and nonoccurrence. As shown in [48], such an event may be characterized as a fuzzy subset,  $A$ , of the sample space  $\Omega$ , with  $\mu_A$ , the membership function of  $A$ , being a measurable function.

Second, even if  $A$  is a well-defined nonfuzzy event, its probability,  $P(A)$ , may be ill-defined. For example, in response to the question, "What is the probability that the Dow Jones average of stock prices will be higher in a month from now?" it would be patently unreasonable to give an unequivocal numerical



answer, e. g. , 0.7. In this instance, a vague response like "quite probable," would be much more commensurate with our lack of understanding of the dynamics of stock prices, and hence a more realistic-if less precise-characterization of the probability in question.

The limitations imposed by the assumption that  $A$  is well-defined may be removed, at least in part, by allowing  $A$  to be a fuzzy event, as was done in [48]. Another and perhaps more important step that can be taken to widen the applicability of probability theory to ill-defined problems is to allow  $P$  to be a linguistic variable in the sense defined in Part II, Sec. 3. In what follows, we shall outline a way in which this can be done and explore some of the elementary consequences of allowing  $P$  to be a linguistic variable.

### *Linguistic probabilities*

To simplify our exposition, we shall assume that the object of our concern is a variable,  $X$ , whose universe of discourse,  $U$ , is a finite set

$$U = u_1 + u_2 + \dots + u_n. \quad (1.1)$$

Furthermore, we assume that the restriction imposed by  $X$  coincides with  $U$ . Thus, any point in  $U$  can be assigned as a value to  $X$ .

With each  $u_i$ ,  $i = 1, \dots, n$ , we associate a *linguistic probability*,  $\mathcal{P}_i$ , which is a Boolean linguistic variable in the sense of Part II, Definition 2.2, with  $p_i$ ,  $0 \leq p_i \leq 1$ , representing the base variable for  $\mathcal{P}_i$ . For concreteness, we shall assume that  $V$ , the universe of discourse associated with  $\mathcal{P}_i$ , is either the unit

interval  $[0,1]$  or the finite set

$$V = 0 + 0.1 + \dots + 0.9 + 1. \quad (1.2)$$

Using  $\mathcal{P}$  as a generic name for the  $\mathcal{S}$ , the term-set for  $\mathcal{P}$  will typically be the following.

$$\begin{aligned} T(\mathcal{P}) = & \textit{likely} + \textit{not likely} + \textit{unlikely} \\ & + \textit{very likely} + \textit{more or less likely} \\ & + \textit{very unlikely} + \dots \\ & + \textit{probable} + \textit{improbable} + \textit{very probable} + \dots \\ & + \textit{neither very probable nor very improbable} + \dots \\ & + \textit{close to 0} + \textit{close to 0.1} + \dots + \textit{close to 1} + \dots \\ & + \textit{very close to 0} + \textit{very close to 0.1} + \dots, \quad (1.3) \end{aligned}$$

in which *likely*, *probable* and *close to* play the role of primary terms.

The shape of the membership function of *likely* will be assumed to be like that of *true* [see Part I, Eq. (3.2)], with *not likely* and *unlikely* defined by

$$\mu_{\textit{not likely}}(p) = 1 - \mu_{\textit{likely}}(p), \quad (1.4)$$

and

$$\mu_{\textit{unlikely}}(p) = \mu_{\textit{likely}}(1-p), \quad (1.5)$$

where  $p$  is a generic name for the  $p$ .

Example 1.1. A graphic example of the meaning attached to the terms *likely*, *not likely*, *very likely* and *unlikely* is shown in Fig. 1. In numerical terms, if the primary term *likely* is defined as

$$\textit{likely} = 0.5/0.6 + 0.7/0.7 + 0.9/0.8 + 1/0.9 + 1/1 \quad (1.6)$$

then

$$\begin{aligned} \textit{not likely} = & 1/(0 + 0.1 + 0.2 + 0.3 + 0.4 + 0.5) + 0.5/0.6 + \\ & 0.3/0.7 + 0.1/0.8, \quad (1.7) \end{aligned}$$

$$\textit{unlikely} = 1/0 + 1/0.1 + 0.9/0.2 + 0.7/0.3 + 0.5/0.4 \quad (1.8)$$

and

$$\text{very likely} = 0.25/0.6 + 0.49/0.7 + 0.81/0.8 + 1/0.9 + 1/1. \quad (1.9)$$

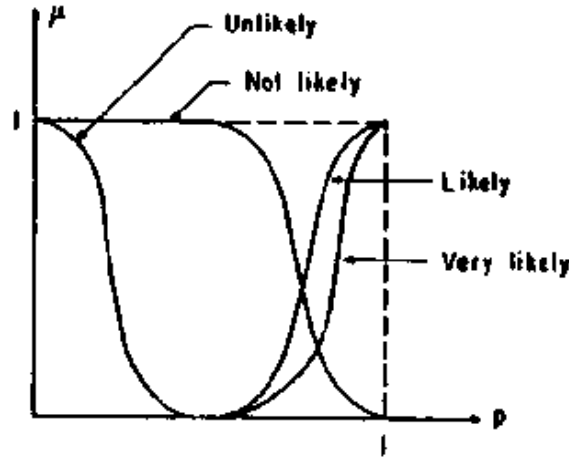

Fig. 1. Compatibility functions of *likely*, *not likely*, *unlikely* and *very likely*.

The term *probable* will be assumed to be more or less synonymous with *likely*. The term *close to  $\alpha$* , where  $\alpha$  is a point in  $[0, 1]$ , will be abbreviated as  $\vec{\alpha}$  or, alternatively, as " $\alpha$ ",<sup>①</sup>, suggesting that  $\alpha$  is a "best example" of the fuzzy set " $\alpha$ ". In this sense, then,

$$\text{likely} \triangleq \text{close to } 1 \triangleq "1", \quad (1.10)$$

$$\text{unlikely} \triangleq \text{close to } 0 \triangleq "0", \quad (1.11)$$

and

$$\text{close to } 0.8 \triangleq "0.8" = 0.6/0.7 + 1/0.8 + 0.6/0.9, \quad (1.12)$$

from which it follows that

① The symbol " $\alpha$ " will be employed in place of  $\vec{\alpha}$  when the constraints imposed by typesetting dictate its use.

$$\begin{aligned}
\text{very close to } 0.8 &= \text{very}^{\Delta} 0.8 \\
&= ("0.8")^2 \text{ [in the sense of Part I, Eq.} \\
&\quad (2.38)] \\
&= 0.36/0.7 + 1/0.8 + 0.36/0.9.
\end{aligned}$$

A particular term in  $T(\mathcal{P})$  will be denoted by  $T_j$ , or  $T_{j\alpha}$  in case a double subscript notation is needed. Thus, if  $T_4 = \text{very likely}$ , then  $T_{43}$  would indicate that *very likely* is assigned as a value to the linguistic variable  $\mathcal{P}_3$ .

The  $n$ -ary linguistic variable  $(\mathcal{P}_1, \dots, \mathcal{P}_n)$  constitutes a *linguistic probability assignment list* associated with  $X$ . A variable  $X$  which is associated with a linguistic probability assignment list will be referred to as a *linguistic random variable*. By analogy with linguistic truth-value distributions [see Part I, Eq. (3.74)], a collection of probability assignment lists will be referred to as a *linguistic probability distribution*.

The assignment of a probability-value  $T_j$  to  $P_i$  may be expressed as

$$P_i = T_j, \quad (1.13)$$

where  $P_i$  is used in a dual role as a generic name for the fuzzy variables which comprise  $\mathcal{P}_i$ . For example, we may write

$$\begin{aligned}
P_3 &= T_4 \\
&= \text{very likely}
\end{aligned} \quad (1.14)$$

in which case *very likely* will be identified as  $T_{43}$  (i. e.,  $T_4$  assigned to  $P_3$ ).

An important characteristic of the linguistic probabilities  $P_1, \dots, P_n$  is that they are  $\beta$ -interactive in the sense of Part I, Definition 3.2. The interaction between the  $P_i$  is a consequence of the constraint  $(+ \stackrel{\Delta}{=} \text{arithmetic sum})$

$$p_1 + p_2 + \dots + p_n = 1, \quad (1.15)$$

in which the  $p_i$  are the base variables (i. e., numerical probabilities) associated with the  $P_i$ .

More concretely, let  $R(p_1 + \dots + p_n = 1)$  denote the nonfuzzy  $n$ -ary relation in  $[0, 1] \times \dots \times [0, 1]$  representing (1.15). Furthermore, let  $R(P_i)$  denote the restriction on the values of  $p_i$ . Then the restriction imposed by the  $n$ -ary fuzzy variable  $(P_1, \dots, P_n)$  may be expressed as

$$R(P_1, \dots, P_n) = R(P_1) \times \dots \times R(P_n) \cap R(p_1 + \dots + p_n = 1). \quad (1.16)$$

which implies that, apart from the constraint imposed by (1.15), the fuzzy variables  $P_1, \dots, P_n$  are noninteractive.

Example 1.2. Suppose that

$$\begin{aligned} P_1 &= \text{likely} \\ &= 0.5/0.8 + 0.8/0.9 + 1/1 \end{aligned} \quad (1.17)$$

and

$$\begin{aligned} P_2 &= \text{unlikely} \\ &= 1/0 + 0.8/0.1 + 0.5/0.2. \end{aligned} \quad (1.18)$$

Then

$$\begin{aligned} R(P_1) \times R(P_2) &= \text{likely} \times \text{unlikely} \\ &= (0.5/0.8 + 0.8/0.9 + 1/1) \times (1/0 + 0.8/0.1 + 0.5/0.2) \\ &= 0.5/(0.8, 0) + 0.8/(0.9, 0) + 1/(1, 0) \\ &\quad + 0.5/(0.8, 0.1) + 0.8/(0.9, 0.1) \\ &\quad + 0.8/(1, 0.1) + 0.5/(0.8, 0.2) \\ &\quad + 0.5/(0.9, 0.2) + 0.5(1, 0.2). \end{aligned} \quad (1.19)$$

As for  $R(p_1 + \dots + p_n = 1)$ , it can be expressed as

$$R(p_1 + p_2 = 1) = \sum_k 1/(k, 1-k), \quad k=0, 0.1, \dots, 0.9, 1 \quad (1.20)$$

and forming the intersection of (1.19) and (1.20), we obtain

$$R(P_1, P_2) = 1/(1, 0) + 0.8/(0.9, 1) + 0.5/(0.8, 0.2) \quad (1.21)$$

as the expression for the restriction imposed by  $(P_1, P_2)$ . Obviously,  $R(P_1, P_2)$  comprises those terms in  $R(P_1) \times R(P_2)$  which satisfy the constraint (1.15).

Remark 1.1. It should be observed that  $R(P_1, P_2)$  as expressed by (1.21) is a normal restriction [see Part I, Eq. (3.23)]. This will be the case, more generally, when the  $P_i$  are of the form

$$P_i = "q_i", \quad i=1, \dots, n \quad (1.22)$$

and  $q_1 + \dots + q_n = 1$ . Note that in Example 1.2, we have

$$P_1 = "1", \quad (1.23)$$

$$P_2 = "0" \quad (1.24)$$

and

$$1 + 0 = 1. \quad (1.25)$$

#### *Computation with linguistic probabilities*

In many of the applications of probability theory, e. g., in the calculation of means, variances, etc., one encounters linear combinations of the form ( $+ \triangleq$  arithmetic sum)

$$z = a_1 p_1 + \dots + a_n p_n, \quad (1.26)$$

where the  $a_i$  are real numbers and the  $p_i$  are probability-values in  $[0, 1]$ . Computation of the value of  $z$  given the  $a_i$  and the  $p_i$  presents no difficulties when the  $p_i$  are points in  $[0, 1]$ . It becomes, however, a nontrivial problem when the probabilities

question are linguistic in nature, that is, when

$$Z = a_1 P_1 + \dots + a_n P_n, \quad (1.27)$$

where the  $P_i$  represent linguistic probabilities with names such as *likely*, *unlikely*, *very likely*, *close to  $\alpha$* , etc. Correspondingly,  $Z$  is not a real number—as it is in (1.26)—but a fuzzy subset of the real line  $W \triangleq (-\infty, \infty)$ , with the membership function of  $Z$  being a function of those of the  $P_i$ .

Assuming that the fuzzy variables  $P_1, \dots, P_n$  are noninteractive [apart from the constraint expressed by (1.15)], the restriction imposed by  $(P_1, \dots, P_n)$  assumes the form [see (1.16)]

$$R(P_1, \dots, P_n) = R(P_1) \times \dots \times R(P_n) \cap R(p_1 + \dots + p_n = 1). \quad (1.28)$$

Let  $\mu(p_1, \dots, p_n)$  be the membership function of  $R(P_1, \dots, P_n)$ , and let  $\mu_i(p_i)$  be that of  $R(P_i)$ ,  $i = 1, \dots, n$ . Then, by applying the extension principle [Part I, Eq. (3.90)] to (1.26), we can express  $Z$  as a fuzzy set (+  $\triangleq$  arithmetic sum)

$$Z = \int_W \mu(p_1, \dots, p_n) / (a_1 p_1 + \dots + a_n p_n), \quad (1.29)$$

which in view of (1.28) may be written as

$$Z = \int_W \mu_1(p_1) \wedge \dots \wedge \mu_n(p_n) / (a_1 p_1 + \dots + a_n p_n) \quad (1.30)$$

with the understanding that the  $p_i$  in (1.30) are subject to the constraint

$$p_1 + \dots + p_n = 1. \quad (1.31)$$

In this way, we can express a linear combination of linguistic probability-values, as a fuzzy subset of the real line.

The expression for  $Z$  may be cast into other forms which may be more convenient for computational purposes. Thus, let  $\mu(z)$  denote the membership function of  $Z$ , with  $z \in W$ . Then (1.30) implies that

$$\mu(z) = \bigvee_{p_1, \dots, p_n} \mu_1(p_1) \wedge \dots \wedge \mu_n(p_n), \quad (1.32)$$

subject to the constraints

$$z = a_1 p_1 + \dots + a_n p_n, \quad (1.33)$$

$$p_1 + \dots + p_n = 1. \quad (1.34)$$

In this form, the computation of  $Z$  reduces to the solution of a nonlinear programming problem with linear constraints. In more explicit terms, this problem may be expressed as: Maximize  $z$  subject to the constraints (+  $\triangleq$  arithmetic sum)

$$\left. \begin{array}{l} \mu_1(p_1) \geq z, \\ \dots \\ \mu_n(p_n) \geq z, \\ z = a_1 p_1 + \dots + a_n p_n, \\ p_1 + \dots + p_n = 1. \end{array} \right\} \quad (1.35)$$

Example 1.3. As a very simple illustration, assume that

$$P_1 = \text{likely} \quad (1.36)$$

and

$$P_2 = \text{unlikely}, \quad (1.37)$$

where

$$\text{likely} = \int_0^1 \mu_{\text{likely}}(p) / p \quad (1.38)$$

and

$$\text{unlikely} = \neg \text{likely} \quad (1.39)$$

Thus [see (1.5)]



$$\mu_{unlikel\ y}(p) = \mu_{likel\ y}(1-p), 0 \leq p \leq 1. \quad (1.40)$$

Suppose that we wish to compute the expectation ( $\triangleq$  arithmetic sum)

$$Z = a_1 \text{likel\ y} + a_2 \text{unlikel\ y}. \quad (1.41)$$

Using (1.32), we have

$$\mu(z) = \bigvee_{p_1, p_2} \mu_{likel\ y}(p_1) \wedge \mu_{unlikel\ y}(p_2), \quad (1.42)$$

subject to the constraints

$$\begin{aligned} z &= a_1 p_1 + a_2 p_2, \\ p_1 + p_2 &= 1. \end{aligned} \quad (1.43)$$

Now in view of (1.40), if  $p_1 + p_2 = 1$ , then

$$\mu_{likel\ y}(p_1) = \mu_{unlikel\ y}(p_2), \quad (1.44)$$

and hence (1.42) reduces to

$$\begin{aligned} \mu(z) &= \mu_{likel\ y}(p_1), \\ z &= a_1 p_1 + a_2 (1-p_1), \end{aligned} \quad (1.45)$$

or, more explicitly,

$$\mu(z) = \mu_{likel\ y} \left( \frac{z - a_2}{a_1 - a_2} \right). \quad (1.46)$$

This result implies that the fuzziness in our knowledge of the probability  $p_1$  induces a corresponding fuzziness in the expectation of [see Fig. 2]

$$z = a_1 p_1 + a_2 p_2.$$

If the universe of probability-values is assumed to be  $V = 0 + 0.1 + \dots + 0.9 + 1$ , then the expression for  $Z$  can be obtained more directly by using the extension principle in the form given in Part I, Eq. (3.97). As an illustration, assume that

$$P_1 = "0.3" = 0.8/0.2 + 1/0.3 + 0.6/0.4, \quad (1.47)$$

$$P_2 = "0.7" = 0.8/0.6 + 1/0.7 + 0.6/0.8, \quad (1.48)$$

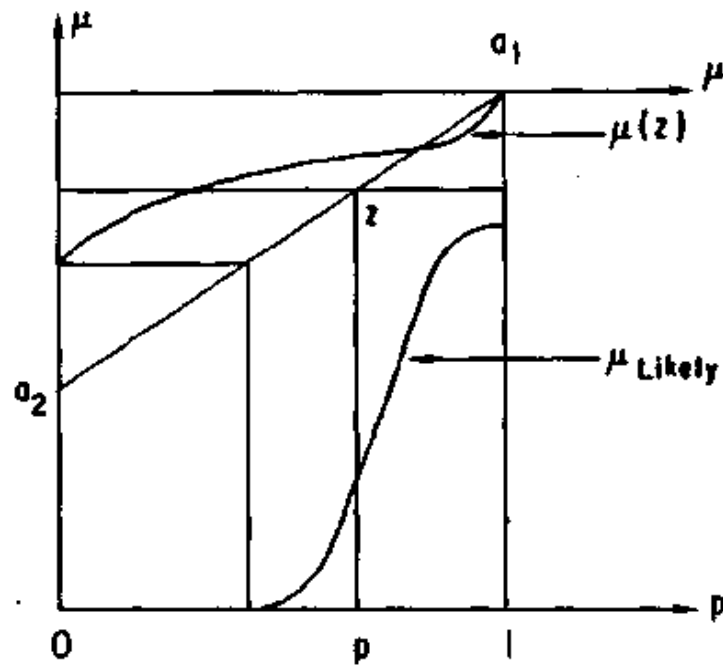

Fig. 2. Computation of the linguistic value of  $a_1p_1 + a_2p_2$ .

and ( $\oplus \triangleq$  arithmetic sum)

$$Z = a_1P_1 \oplus a_2P_2 \quad (1.49)$$

where the symbol  $\oplus$  is used to avoid confusion with the union.

On substituting (1.47) and (1.48) in (1.49), we obtain

$$\begin{aligned} Z &= a_1(0.8/0.2 + 1/0.3 + 0.6/0.4) \\ &\quad \oplus a_2(0.8/0.6 + 1/0.7 + 0.6/0.8) \\ &= (0.8/0.2a_1 + 1/0.3a_1 + 0.6/0.4a_1) \\ &\quad \oplus (0.8/0.6a_2 + 1/0.7a_2 + 0.6/0.8a_2). \quad (1.50) \end{aligned}$$

In expanding the right-hand side of (1.50), we have to take into account the constraint  $p_1 + p_2 = 1$ , which means that a term of the form

$$\mu_1/p_1a_1 \oplus \mu_2/p_2a_2 \quad (1.51)$$

evaluates to

$$\begin{aligned} \mu_1/p_1a_1 \oplus \mu_2/p_2a_2 &= \mu_1 \wedge \mu_2 / (p_1a_1 \oplus p_2a_2) && \text{if } p_1 + p_2 = 1 \\ &= 0 && \text{otherwise.} \end{aligned} \quad (1.52)$$

In this way, we obtain

$$\begin{aligned} Z &= 1/(0.3a_1 \oplus 0.7a_2) + 0.6/(0.2a_1 \oplus 0.8a_2) \\ &\quad + 0.6/(0.4a_1 \oplus 0.6a_2), \end{aligned} \quad (1.53)$$

which expresses  $Z$  as a fuzzy subset of the real line  $W = (-\infty, \infty)$ .

#### *Averages over fuzzy sets*

Our point of departure in the foregoing discussion was the assumption that with each point  $u_i$  of a finite<sup>①</sup> universe of discourse  $U$  is associated a linguistic probability-value  $P_i$  which is a component of a linguistic probability distribution  $(\mathcal{P}_1, \dots, \mathcal{P}_n)$ .

In this context, a fuzzy subset,  $A$ , of  $U$  plays the role of a *fuzzy event*. Let  $\mu_A(u_i)$  be the grade of membership of  $u_i$  in  $A$ . Then, if the  $P_i$  are conventional numerical probabilities,  $p_i, 0 \leq p_i \leq 1$ , then the probability of  $A$ ,  $P(A)$ , is defined as (see [48]; +  $\triangleq$  arithmetic sum)

$$P(A) = \mu_A(u_1)p_1 + \dots + \mu_A(u_n)p_n. \quad (1.54)$$

It is natural to extend this definition to linguistic probabilities by defining the linguistic probability<sup>②</sup> of  $A$  as

$$P(A) = \mu_A(u_1)P_1 + \dots + \mu_A(u_n)P_n \quad (1.55)$$

with the understanding that the right-hand side of (1.55) is a

① The assumption that  $U$  is a finite set is made solely for the purpose of simplifying our exposition. More generally,  $U$  can be a countable set or a continuum.

② It should be noted that the computation of the right-hand side of (1.55) defines  $P(A)$  as a fuzzy subset of  $[0, 1]$ . In general a linguistic approximation would be needed to express  $P(A)$  as a linguistic probability-value.

linear form in the sense of (1.27). In connection with (1.55), it should be noted that the constraint

$$p_1 + \dots + p_n = 1 \quad (1.56)$$

on the underlying probabilities, together with the fact that

$$0 \leq \mu_A(u_i) \leq 1, i = 1, \dots, n,$$

insures that  $P(A)$  is a fuzzy subset of  $[0, 1]$ .

**Example 1.4.** As a very simple illustration, assume that

$$U = a + b + c, \quad (1.57)$$

$$A = 0.4a + b + 0.8c, \quad (1.58)$$

$$P_a = "0.3" = 0.6/0.2 + 1/0.3 + 0.6/0.4, \quad (1.59)$$

$$P_b = "0.6" = 0.6/0.5 + 1/0.6 + 0.6/0.7, \quad (1.60)$$

$$P_c = "0.1" = 0.6/0 + 1/0.1 + 0.6/0.2. \quad (1.61)$$

Then ( $\oplus \triangleq$  arithmetic sum)

$$P(A) = 0.4(0.6/0.2 + 1/0.3 + 0.6/0.4) \oplus (0.6/0.5 + 1/0.6 + 0.6/0.7) \oplus 0.8(0.6/0 + 1/0.1 + 0.6/0.2), \quad (1.62)$$

subject to the constraint

$$p_1 + p_2 + p_3 = 1. \quad (1.63)$$

Picking those terms in (1.62) which satisfy (1.63), we obtain

$$\begin{aligned} P(A) = & 0.6/(0.4 \times 0.2 \oplus 0.6 \oplus 0.8 \times 0.2) \\ & + 0.6/(0.4 \times 0.2 \oplus 0.7 \oplus 0.8 \times 0.1) \\ & + 0.6/(0.4 \times 0.3 \oplus 0.5 \oplus 0.8 \times 0.2) \\ & + 1/(0.4 \times 0.3 \oplus 0.6 \oplus 0.8 \times 0.1) \\ & + 0.6/(0.4 \times 0.3 \oplus 0.7) \\ & + 0.6/(0.4 \times 0.4 \oplus 0.5 \oplus 0.8 \times 0.1) \\ & + 0.6/(0.4 \times 0.4 \oplus 0.6), \end{aligned} \quad (1.64)$$

which reduces to

$$P(A) = 0.6/(0.84 + 0.86 + 0.78 + 0.82$$

$$+0.74)+1/0.8, \quad (1.65)$$

and which may be roughly approximated as

$$P(A) = "0.8". \quad (1.66)$$

The linguistic probability of a fuzzy event as expressed by (1.55) may be viewed as a particular instance of a more general concept, namely, the *linguistic average* or, equivalently, the *linguistic expectation* of a function (defined on  $U$ ) over a fuzzy subset of  $U$ . More specifically, let  $f$  be a real-valued function defined on  $U$ ; let  $A$  be a fuzzy subset of  $U$ ; and let  $P_1, \dots, P_n$  be the linguistic probabilities associated with  $u_1, \dots, u_n$ , respectively. Then, the *linguistic average of  $f$  over  $A$*  is denoted by  $Av(f; A)$  and is defined by ( $+ \triangleq$  arithmetic sum)

$$Av(f; A) = f(u_1)\mu_A(u_1)P_1 + \dots + f(u_n)\mu_A(u_n)P_n. \quad (1.67)$$

A concrete example of (1.67) is the following. Assume that individuals named  $u_1, \dots, u_n$  are chosen with linguistic probabilities  $P_1, \dots, P_n$ , with  $P_i$  being a restriction on  $P$ ,  $i = 1, \dots, n$ . Suppose that  $u_i$  is fined an amount  $f(u_i)$ , which is scaled down in proportion to the grade of membership of  $u_i$  in a class  $A$ . Then, the linguistic average (expected) amount of the fine will be expressed by (1.67).

Comment 1.1. Note that (1.67) is basically a linear combination of the form (1.27) with

$$a_i = f(u_i)\mu_A(u_i). \quad (1.68)$$

Thus, to evaluate (1.67), we can employ the technique described earlier for the computation of linear forms in linguistic probabilities. In particular, it should be noted that, in the special case where  $f(u_i) = 1$ , the right-hand side of (1.67) becomes

$$\mu_A(u_1)P_1 + \dots + \mu_A(u_n)P_n, \quad (1.69)$$

and  $\text{Av}(f;A)$  reduces to  $P(A)$ .

In addition to subsuming the expression for  $P(A)$ , the expression for  $\text{Av}(f;A)$  subsumes as special cases other types of averages which occur in various applications. Among them there are two that may be regarded as degenerate forms of (1.67) and which are encountered in many problems of practical interest. In what follows, we shall dwell briefly on these averages and, for convenience in exposition, will state their definitions in the form of answers to questions.

Question 1.1. What is the number of elements in a given fuzzy set  $A$ ? Clearly, this question is not well posed, since in the case of a fuzzy set the dividing line between membership and nonmembership is not sharp. Nevertheless, the concept of the *power* of a fuzzy set [49], which is defined as

$$|A| \triangleq \sum \mu_A(u_i), \quad (1.70)$$

appears to be a natural generalization of that of the number of elements in  $A$ .

As an illustration of  $|A|$ , suppose that  $U$  is the universe of residents in a city, and  $A$  is the fuzzy set of the unemployed in that city. If  $\mu_A(u_i)$  is interpreted as the grade of membership of an individual,  $u_i$ , in the class of the unemployed [e. g.,  $\mu_A(u_i) = 0.5$  if  $u_i$  is working half-time and is looking for a full-time job], then  $|A|$  may be interpreted as the number of *full-time equivalent* unemployed.

Question 1.2. Suppose that  $f$  is a real-valued function defined on  $U$ . What is the average value of  $f$  over a fuzzy subset,

$A$ , of  $U$ ?

Using the same notation as in (1.67), let  $A_V(f; A)$  denote the average value of  $f$  over  $A$ . If  $A$  were nonfuzzy,  $A_V(f; A)$  would be expressed by

$$A_V(f; A) = \frac{\sum_{u_i \in A} f(u_i)}{|A|}, \quad (1.71)$$

where  $\sum_{u_i \in A}$  is the summation over those  $u_i$  which are in  $A$ , and  $|A|$  is the number of the  $u_i$  which are in  $A$ . To extend (1.71) to fuzzy sets, we note that (1.71) may be rewritten as

$$A_V(f; A) = \frac{\sum_{u_i \in U} f(u_i) \mu_A(u_i)}{\sum_{u_i \in U} \mu_A(u_i)}, \quad (1.72)$$

where  $\mu_A$  is the characteristic function of  $A$ . Then, we adopt (1.72) as the definition of  $A_V(f; A)$  for a fuzzy  $A$  by interpreting  $\mu_A(u_i)$  as the grade of membership of  $u_i$  in  $A$ . In this way, we arrive at an expression for  $A_V(f; A)$  which may be viewed as a special case of (1.67).

As an illustration of (1.72), suppose that  $U$  is the universe of residents in a city and  $A$  is the fuzzy subset of residents who are *young*. Furthermore, assume that  $f(u_i)$  represents the income of  $u_i$ . Then, the average income of young residents in the city would be expressed by (1.72).

Comment 1.2. Since the expression for  $|A|$  is a linear form in the  $\mu_A(u_i)$ , the power of a fuzzy set of type 2 (see Part I, Definition 3.1) can readily be computed by employing the technique which we had used earlier to compute  $P(A)$ . In the case of  $A_V(f; A)$ , however, we are dealing with a ratio of linear forms, and hence the computation of  $A_V(f; A)$  for fuzzy sets of type 2 presents a more difficult problem.

In the foregoing discussion, our very limited objective was to indicate that the concept of a linguistic variable provides a basis for defining linguistic probabilities and, in conjunction with the extension principle, may be applied to the computation of linear forms in such probabilities. We shall not dwell further on this subject and, in what follows, will turn our attention to a basic rule of inference in fuzzy logic.

## 2. Compositional rule of inference and approximate reasoning

The basic rule of inference in traditional logic is the *modus ponens*, according to which we can infer the truth of a proposition  $B$  from the truth of  $A$  and the implication  $A \Rightarrow B$ . For example, if  $A$  is identified with "John is in a hospital," and  $B$  with "John is ill," then if it is true that "John is in a hospital," it is also true that "John is ill."

In much of human reasoning, however, *modus ponens* is employed in an approximate rather than exact form. Thus, typically, we know that  $A$  is true and that  $A^* \Rightarrow B$ , where  $A^*$  is, in some sense, an approximation to  $B$ . Then, from  $A$  and  $A^* \Rightarrow B$  we may infer that  $B$  is approximately true.

In what follows, we shall outline a way of formalizing approximate reasoning based on the concepts introduced in the preceding sections. However, in a departure from traditional logic, our main tool will not be the *modus ponens*, but a so-called *compositional rule of inference* of which *modus ponens* forms a very special case.

### *Compositional rule of inference*

The compositional rule of inference is merely a



generalization of the following familiar procedure. Referring to Fig. 3, suppose that we have a curve  $y=f(x)$  and are given  $x=a$ . Then from  $y=f(x)$  and  $x=a$ , we can infer  $y \triangleq b = f(a)$ .

Next, let us generalize the above process by assuming that  $a$  is an interval and  $f(x)$  is an interval-valued function such as shown in Fig. 4. In this instance, to find the interval  $y \triangleq b$  which

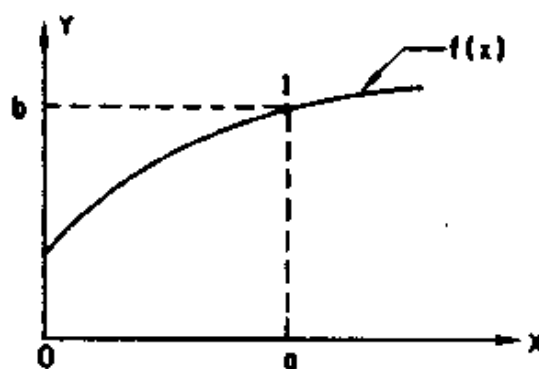

Fig. 3. Inferring  $y=b$  from  $x=a$  and  $y=f(x)$

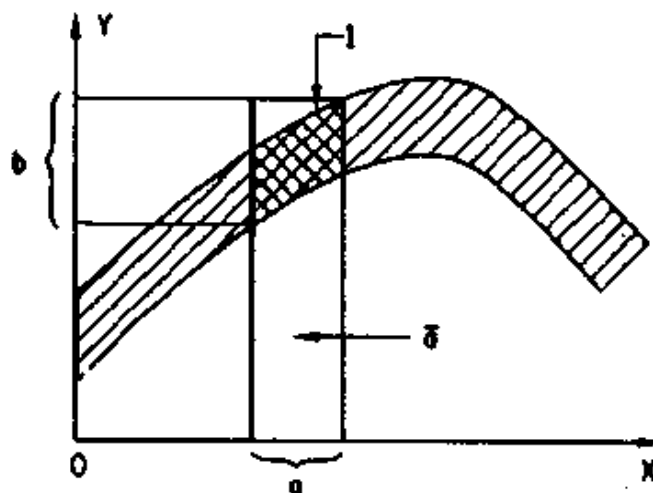

Fig. 4. Illustration of the compositional rule of inference in the case of interval-valued variables.

corresponds to the interval  $a$ , we first construct a cylindrical set,  $\bar{a}$ , with base  $a$  [see Part 1, Eq. (3.58)] and find its intersection,  $I$ , with the interval-valued curve. Then we project the intersection on the  $OY$  axis, yielding the desired  $y$  as the interval  $b$ .

Going one step further in our chain of generalizations, assume that  $A$  is a fuzzy subset of the  $OX$  axis and  $F$  is a fuzzy relation from  $OX$  to  $OY$ . Again, forming a cylindrical fuzzy set  $\bar{A}$  with base  $A$  and intersecting it with the fuzzy relation  $F$  (see Fig. 5), we obtain a fuzzy set  $\bar{A} \cap F$  which is the analog of the point of intersection  $I$  in Fig. 3. Then, projecting this set on  $OY$ , we obtain  $y$  as a fuzzy subset of  $OY$ . In this way, from  $y=f(x)$  and  $x \triangleq A$  (fuzzy subset of  $OX$ ), we infer  $y$  as a fuzzy subset,  $B$ , of  $OY$ .

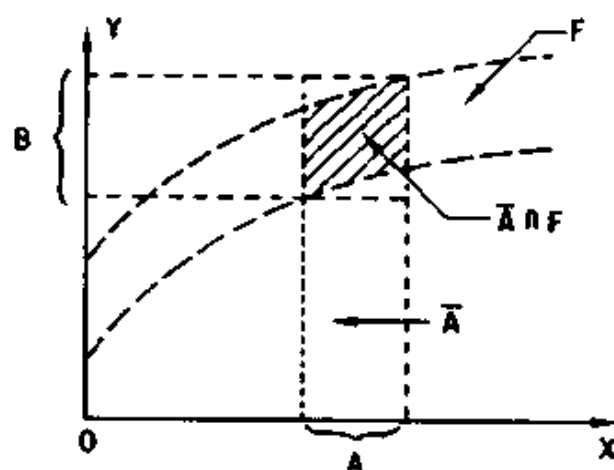

Fig. 5. Illustration of the compositional rule of inference for fuzzy variables.

More specifically, let  $\mu_A$ ,  $\mu_{\bar{A}}$ ,  $\mu_F$  and  $\mu_B$  denote the

membership functions of  $A, \bar{A}, F$  and  $B$ , respectively. Then, by the definition of  $\bar{A}$  [see Part I, Eq. (3.58)]

$$\mu_{\bar{A}}(x, y) = \mu_A(x), \quad (2.1)$$

and consequently

$$\begin{aligned} \mu_{\bar{A} \cap F}(x, y) &= \mu_{\bar{A}}(x, y) \wedge \mu_F(x, y) \\ &= \mu_A(x) \wedge \mu_F(x, y). \end{aligned} \quad (2.2)$$

Projecting  $\bar{A} \cap F$  on the  $OY$  axis, we obtain from (2.2) and from Eq. (3.57) of Part I

$$\mu_B(y) = \vee_x \mu_A(x) \wedge \mu_F(x, y) \quad (2.3)$$

as the expression for the membership function of the projection (shadow) of  $\bar{A} \cap F$  on  $OY$ . Comparing this expression with the definition of the composition of  $A$  and  $F$  [see Part I, Eq. (3.55)], we see that  $B$  may be represented as

$$B = A \circ F, \quad (2.4)$$

where  $\circ$  denotes the operation of composition. As stated in Part I, Sec. 3, this operation reduces to the max-min matrix product when  $A$  and  $F$  have finite supports.

**Example 2.1.** Suppose that  $A$  and  $F$  are defined by

$$A = 0.2/1 + 1/2 + 0.3/3 \quad (2.5)$$

and

$$\begin{aligned} F &= 0.8/(1,1) + 0.9/(1,2) + 0.2/(1,3) \\ &\quad + 0.6/(2,1) + 1/(2,2) + 0.4/(2,3) \\ &\quad + 0.5/(3,1) + 0.8/(3,2) + 1/(3,3). \end{aligned} \quad (2.6)$$

Expressing  $A$  and  $F$  in terms of their relation matrices and forming the matrix product (2.4), we obtain

$$\begin{array}{ccc}
 A & F & B \\
 [0.2 \quad 1 \quad 0.3] \circ & \begin{bmatrix} 0.8 & 0.9 & 0.2 \\ 0.6 & 1 & 0.4 \\ 0.5 & 0.8 & 1 \end{bmatrix} & = [0.6 \quad 1 \quad 0.4].
 \end{array}
 \tag{2.7}$$

The foregoing comments and examples serve to motivate the following rule of inference.

Rule 2.1. Let  $U$  and  $V$  be two universes of discourse with base variables  $u$  and  $v$ , respectively. Let  $R(u, v)$ ,  $R(u, v)$  and  $R(v)$  denote restrictions on  $u$ ,  $(u, v)$  and  $v$ , respectively, with the understanding that  $R(u)$ ,  $R(u, v)$  and  $R(v)$  are fuzzy relations in  $U$ ,  $U \times V$  and  $V$ . Let  $A$  and  $F$  denote particular fuzzy subsets of  $U$  and  $U \times V$ . Then the *compositional rule of inference* asserts that the solution of the *relational assignment equations*

$$R(u) = A \tag{2.8}$$

and

$$R(u, v) = F \tag{2.9}$$

is given by

$$R(v) = A \circ F \tag{2.10}$$

where  $A \circ F$  is the composition of  $A$  and  $F$ . In this sense, we can *infer*  $R(v) = A \circ F$  from  $R(u) = A$  and  $R(u, v) = F$ .

As a simple illustration of the use of this rule, assume that

$$U = V = 1 + 2 + 3 + 4, \tag{2.11}$$

$$A = \textit{small} = 1/1 + 0.6/2 + 0.2/3 \tag{2.12}$$

and

$$\begin{aligned}
 F &= \textit{approximately equal} \\
 &= 1/(1,1) + 1/(2,2) + 1/(3,3) + 1/(4,4) \\
 &\quad + 0.5/[(1,2) + (2,1) + (2,3) + (3,2)]
 \end{aligned}$$

$$+ (3,4) + (4,3)]. \quad (2.13)$$

In other words,  $A$  is unary fuzzy relation in  $U$  named *small* and  $F$  is a binary fuzzy relation in  $U \times V$  named *approximately equal*.

The relational assignment equations in this case read

$$R(u) = \textit{small}, \quad (2.14)$$

$$R(u,v) = \textit{approximately equal} \quad (2.15)$$

and hence

$$R(v) = \textit{small} \circ \textit{approximately equal}$$

$$= [1 \ 0.6 \ 0.2 \ 0] \cdot \begin{bmatrix} 1 & 0.5 & 0 & 0 \\ 0.5 & 1 & 0.5 & 0 \\ 0 & 0.5 & 1 & 0.5 \\ 0 & 0 & 0.5 & 1 \end{bmatrix} \quad (2.16)$$

$$= [1 \ 0.6 \ 0.5 \ 0.2]$$

which may be approximated by the linguistic term

$$R(v) = \textit{more or less small} \quad (2.17)$$

if *more or less* is defined as a fuzzifier [see Part 1, Eq. (3.48)], with

$$\left. \begin{aligned} K(1) &= 1/1 + 0.7/2, \\ K(2) &= 1/2 + 0.7/3, \\ K(3) &= 1/3 + 0.7/4, \\ K(4) &= 1/4. \end{aligned} \right\} \quad (2.18)$$

Note that the application of this fuzzifier to  $R(u)$  yields

$$[1 \ 0.7 \ 0.42 \ 0.14] \quad (2.19)$$

as an approximation to  $[1 \ 0.6 \ 0.5 \ 0.2]$ .

In summary, then by using the compositional rule of inference, we have inferred from  $R(u) = \textit{small}$ , and  $R(u,v) = \textit{approximately equal}$

$$R(v) = [1 \ 0.6 \ 0.5 \ 0.2] \quad \text{exactly} \quad (2.20)$$

and

$$R(v) = \text{more or less small} \quad \text{as a linguistic approximation.} \quad (2.21)$$

Stated in English, this approximate inference may be expressed as

$u$ is small	premiss
$u$ and $v$ are approximately equal	premiss
<hr/>	
$v$ is more or less small	approximate conclusion.

(2.22)

The general idea behind the method sketched above is the following. Each fact or a premiss is translated into a relational assignment equation involving one or more restrictions on the base variables. These equations are solved for the desired restrictions by the use of the composition of fuzzy relations. The solutions to the equations then represent deductions from the given set of premisses.

*modus ponens as a special case  
of the compositional rule of inference*

As we shall see in what follows, *modus ponens* may be viewed as a special case of the compositional rule of inference. To establish this connection, we shall first extend the notion of material implication from propositional variables to fuzzy sets.

In traditional logic, the material implication  $\Rightarrow$  is defined as a logical connective for propositional variables. Thus, if  $A$  and  $B$  are propositional variables, the truth table for  $A \Rightarrow B$  or, equivalently, IF  $A$  THEN  $B$ , is defined by Table 1 (see Part I, Table 2).

Table 1

	<i>B</i>	<i>T</i>	<i>F</i>
<i>A</i>			
<i>T</i>		<i>T</i>	<i>F</i>
<i>F</i>		<i>T</i>	<i>T</i>

In much of human discourse, however, the expression IF *A* THEN *B* is used in situations in which *A* and *B* are fuzzy sets (or fuzzy predicates) rather than propositional variables. For example, in the case of the statement IF John is *ill* THEN John is *cranky*, which may be abbreviated as  $ill \Rightarrow cranky$ , *ill* and *cranky* are, in effect, names of fuzzy sets. The same is true of the statement IF apple is *red* THEN apple is *ripe* play the role of fuzzy sets.

To extend the notion of material implication to fuzzy sets, let *U* and *V* be two possibly different universes of discourse and let *A*, *B* and *C* be fuzzy subsets of *U*, *V* and *V*, respectively. First we shall define the meaning of the expression IF *A* THEN *B* ELSE *C*, and then we shall define IF *A* THEN *B* as a special case of IF *A* THEN *B* ELSE *C*.

Definition 2. 1. The expression IF *A* THEN *B* ELSE *C* is a binary fuzzy relation in  $U \times V$  defined by

$$IF\ A\ THEN\ B\ ELSE\ C = A \times B + \neg A \times C. \quad (2.23)$$

That is, if *A*, *B* and *C* are unary fuzzy relations in *U*, *V* and *V*, then IF *A* THEN *B* ELSE *C* is a binary fuzzy relation in  $U \times V$  which is the union of the Cartesian product of *A* and *B* [see Part I, Eq. (3.45)] and the Cartesian product of the negation of *A* and *C*.

Now IF  $A$  THEN  $B$  may be viewed as a special case of IF  $A$  THEN  $B$  ELSE  $C$  which results when  $C$  is allowed to be the entire universe  $V$ . Thus

$$\begin{aligned} \text{IF } A \text{ THEN } B &\stackrel{\Delta}{=} \text{IF } A \text{ THEN } B \text{ ELSE } V \\ &= A \times B + \neg A \times V. \end{aligned} \quad (2.24)$$

In effect, this amounts to interpreting IF  $A$  THEN  $B$  as IF  $A$  THEN  $B$  ELSE *don't care*.<sup>①</sup>

It is helpful to observe that in terms of the relation matrices of  $A, B$  and  $C$ , (2.23) may be expressed as the sum of dyadic products involving  $A$  and  $B$  (and  $\neg A$  and  $C$ ) as column and row matrices, respectively. Thus,

$$\text{IF } A \text{ THEN } B \text{ ELSE } C = [A][B] + \neg[A][C]. \quad (2.25)$$

Example 2.2. As a simple illustration (2.23) and (2.24), assume that

$$U = V = 1 + 2 + 3, \quad (2.26)$$

$$A = \textit{small} = 1/1 + 0.4/2, \quad (2.27)$$

$$B = \textit{large} = 0.4/2 + 1/3, \quad (2.28)$$

$$C = \textit{not large} = 1/1 + 0.6/2. \quad (2.29)$$

Then

$$\begin{aligned} \text{IF } A \text{ THEN } B \text{ ELSE } C &= (1/1 + 0.4/2) \times (0.4/2 + 1/3) \\ &\quad + (0.6/2 + 1/3) \times (1/1 + 0.6/2) \\ &= 0.4/(1,2) + 1/(1,3) + 0.6/(2,1) \end{aligned}$$

---

① An alternative interpretation that is consistent with Lukasiewicz's definition of implication [46] is expressed by IF  $A$  THEN  $B \stackrel{\Delta}{=} \neg(A \times V) \oplus (U \times B)$ , where the operation  $\oplus$  (bounded sum) is defined for fuzzy sets  $P, Q$  by  $\mu_{P \oplus Q} \stackrel{\Delta}{=} 1 \wedge (\mu_P + \mu_Q)$ , with  $+$  denoting the arithmetic sum. More generally, IF  $A$  THEN  $B$  ELSE  $C \stackrel{\Delta}{=} [\neg(A \times V) \oplus (U \times B)] \cap [(A \times V) \oplus (U \times C)]$ .



$$\begin{aligned}
 &+0.6(2,2)+0.4/(2,3)+1/(3, \\
 1) & \\
 &+0.6/(3,2). \qquad (2.30)
 \end{aligned}$$

which, represented as a relation matrix, reads

$$\text{IF } A \text{ THEN } B \text{ ELSE } C = \begin{bmatrix} 0 & 0.4 & 1 \\ 0.6 & 0.6 & 0.4 \\ 1 & 0.6 & 0 \end{bmatrix} \quad (2.31)$$

Similarly

$$\begin{aligned}
 \text{IF } A \text{ THEN } B &= (1/1+0.4/2) \times (0.4/2+1/3) \\
 &+ (0.6/2+1/3) \times (1/1+1/2+1/3) \\
 &= 0.4/(1,2) + 1/(1,3) + 0.6/(2,1) + \\
 &0.6(2,2) + 0.6/(2,3) + 1/(3,1) + 1/ \\
 &(3,2) + 1/(3,3),
 \end{aligned}$$

or equivalently

$$\text{IF } A \text{ THEN } B = \begin{bmatrix} 0 & 0.4 & 1 \\ 0.6 & 0.6 & 0.6 \\ 1 & 1 & 1 \end{bmatrix} \quad (2.32)$$

Comment 2.1. It should be noted that in defining IF  $A$  THEN  $B$  by (2.24) we are tacitly assuming that  $A$  and  $B$  are noninteractive in the sense that there is no joint constraint involving the base variables  $u$  and  $v$ . This would not be the case in the nonfuzzy statement IF  $u \in A$  THEN  $u \in B$ , which may be expressed as IF  $u \in A$  THEN  $v \in B$ , subject to the constraint  $u = v$ . Denoting this constraint by  $R(u = v)$ , the relation representing the statement in question would be

$$\text{IF } u \in A \text{ THEN } u \in B \stackrel{\Delta}{=} (A \times B + \neg A \times V) \cap [R(u = v)]. \quad (2.33)$$

Remark 2.1. In defining  $A \Rightarrow B$ , we assumed that IF A THEN B is a special case of IF A THEN B ELSE C resulting from setting  $C=V$ . If we set  $C$  equal to  $\theta$ (empty set) rather than  $V$ , the right-hand side of (2.23) reduces to the Cartesian product  $A \times B$  — which may be interpreted as A COUPLED WITH B (rather than A ENTAILS B). Thus, by definition,

$$A \text{ COUPLED WITH } B \stackrel{\Delta}{=} A \times B, \quad (2.34)$$

and hence

$$A \Rightarrow B \stackrel{\Delta}{=} A \text{ COUPLED WITH } B \text{ plus } \neg A \text{ COUPLED WITH } V. \quad (2.35)$$

More generally, an expression of the form

$$A_1 \times B_1 + \dots + A_n \times B_n \quad (2.36)$$

would be expressed in words as

$$A_1 \text{ COUPLED WITH } B_1 \text{ plus...plus } A_n \text{ COUPLED WITH } B_n. \quad (2.37)$$

It should be noted that expressions such as (2.37) may be employed to represent a fuzzy graph as a union of fuzzy points (see Fig. 6). For example, a fuzzy graph  $G$  may be represented as

$$G = "u_1" \times "v_1" + "u_2" \times "v_2" + \dots + "u_n" \times "v_n", \quad (2.38)$$

where the  $u_i$  and  $v_i$  are points in  $U$  and  $V$ , respectively, and " $u_i$ " and " $v_i$ ",  $i=1, \dots, n$ , represent fuzzy sets named *close to*  $u_i$  and *close to*  $v_i$  [see (1.12)].

Comment 2.2. the connection between (2.24) and the conventional definition of material implication becomes clearer by noting that

$$\neg A \times B \subset \neg A \times V \quad (2.39)$$

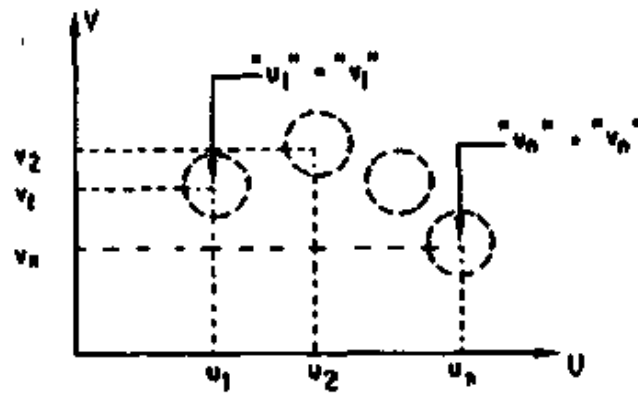

Fig. 6. Representation of a fuzzy graph as a union of fuzzy points.

and hence that (2.24) may be rewritten as

$$\begin{aligned} \text{IF } A \text{ THEN } B &= A \times B + \neg A \times B + \neg A \times V \\ &= (A + \neg A) \times B + \neg A \times V. \end{aligned} \quad (2.40)$$

Now, if  $A$  is a nonfuzzy subset of  $U$ , then

$$A + \neg A = U, \quad (2.41)$$

and hence IF  $A$  THEN  $B$  reduces to

$$\text{IF } A \text{ THEN } B = U \times B + \neg A \times V, \quad (2.42)$$

which is similar in form to the familiar expression for  $A \Rightarrow B$  in the case of propositional variables, namely

$$A \Rightarrow B \equiv \neg A \vee B. \quad (2.43)$$

Turning to the connection between *modus ponens* and the compositional rule of inference, we first define a *generalized modus ponens* as follows.

**Definition 2.2.** Let  $A_1, A_2$  and  $B$  be fuzzy subsets of  $U, U$  and  $V$ , respectively. Assume that  $A_1$  is assigned to the restriction  $R(u)$ , and the relation  $A_2 \Rightarrow B$  [defined by Eq. (3.24) of Part 1] is assigned to the restriction  $R(u, v)$ . Thus

$$R(u) = A_1, \quad (2.44)$$

$$R(u, v) = A_2 \Rightarrow B. \quad (2.45)$$

As was shown earlier, these relational assignment equations may be solved for the restriction on  $v$ , yielding

$$R(v) = A_1 \circ (A_2 \Rightarrow B). \quad (2.46)$$

An expression for this conclusion in the form

$$A_1 \quad \text{premiss} \quad (2.47)$$

$$A_2 \Rightarrow B \quad \text{implication} \quad (2.48)$$

---

$$A_1 \circ (A_2 \Rightarrow B) \quad \text{conclusion} \quad (2.49)$$

constitutes the statement of the *generalized modus ponens*.<sup>①</sup>

Comment 2.3. The above statement differs from the traditional *modus ponens* in two respects: First,  $A_1, A_2$  and  $B$  are allowed to be fuzzy sets, and second,  $A_1$  need not be identical with  $A_2$ . To check on what happens when  $A_1 = A_2 = A$  and  $A$  is nonfuzzy, we substitute the expression for  $A_2 \Rightarrow B$  in (2.46), yielding

$$\begin{aligned} A \circ (A \Rightarrow B) &= A \circ (A \times B + \neg A \times V) \\ &= A_r A_c B_r + A_r (\neg A_c) V_r, \end{aligned} \quad (2.50)$$

where  $r$  and  $c$  stand for *row* and *column*, respectively;  $A_r$  and  $A_c$  denote the relation matrices for  $A$  expressed as a row matrix and a column matrix, respectively; and the matrix product is understood to be taken in the max-min sense.

Now, since  $A$  is nonfuzzy,

$$A_r (\neg A_c) = 0, \quad (2.51)$$

and so long as  $A$  is normal [see Part 1, Eq. (3.23)]

---

<sup>①</sup> The generalized *modus ponens* as defined here is unrelated to probabilistic rules of inference. A discussion of such rules and related issues may be found in [50].

$$A_r A_c = 1. \quad (2.52)$$

Consequently

$$A \circ (A \Rightarrow B) = B, \quad (2.53)$$

which agrees with the conclusion yielded by *modus ponens*.

**Example 2.3.** As a simple illustration of (2.49), assume that

$$U = V = 1 + 2 + 3, \quad (2.54)$$

$$A_2 = \text{small} = 1/1 + 0.4/2, \quad (2.55)$$

$$A_1 = \text{more or less small} = 1/1 + 0.4/2 + 0.2/3 \quad (2.56)$$

and

$$B = \text{large} = 0.4/2 + 1/3. \quad (2.57)$$

Then (see (2.32))

$$\text{small} \Rightarrow \text{large} = \begin{bmatrix} 0 & 0.4 & 1 \\ 0.6 & 0.6 & 0.6 \\ 1 & 1 & 1 \end{bmatrix} \quad (2.58)$$

and

$$\begin{aligned} \text{more or less small} \circ (\text{small} \Rightarrow \text{large}) &= [1 \quad 0.4 \quad 0.2] \circ \\ &\quad \begin{bmatrix} 0 & 0.4 & 1 \\ 0.6 & 0.6 & 0.6 \\ 1 & 1 & 1 \end{bmatrix} \\ &= [0.4 \quad 0.4 \quad 1], \end{aligned} \quad (2.59)$$

which may be roughly approximated as *more or less large*. Thus, in the case under consideration, the *generalized modus ponens* yields

<i>u is more or less small</i>	premiss
IF <i>u is small</i> THEN <i>v is large</i>	implication
<i>v is more or less large</i>	approximate conclusion
	(2.60)

Comment 2.4. Because of the way in which  $A \Rightarrow B$  is defined, namely,

$$A \Rightarrow B = A \times B + \neg A \times V,$$

the grade of membership of a point  $(u, v)$  will be high in  $A \Rightarrow B$  if the grade of membership of  $u$  is low in  $A$ . This gives rise to an overlap between the terms  $A \times B$  and  $\neg A \times V$  when  $A$  is fuzzy, with the result that [see (2.50)], the inference drawn from  $A$  and  $A \Rightarrow B$  is not  $B$  but<sup>①</sup>

$$A \circ (A \Rightarrow B) = B + A \circ (\neg A \times V), \quad (2.61)$$

where the difference term  $A \circ (\neg A \times V)$  represents the effect of the overlap.

To avoid this phenomenon it may be necessary to define  $A \Rightarrow B$  in a way that differentiates between the numerical truth-values in  $[0, 1]$  and the truth-value *unknown* [see Part I, Eq. (3.52)]. Also, it should be noted that for  $A$  COUPLED WITH  $B$  [see (2.34)], we do have

$$A \circ (A \text{ COUPLED WITH } B) = B \quad (2.62)$$

so long as  $A$  is a normal fuzzy set.

### *Fuzzy theorems*

By a fuzzy theorem of an assertion we mean a statement, generally of the form IF  $A$  THEN  $B$ , whose truth-value is *true* in

---

① We assume that  $A$  is normal, so that  $A \circ A_c = 1$ .

an approximate sense and which can be inferred from a set of axioms by the use of approximate reasoning, e. g. , by repeated application of the generalized *modus ponens* or similar rules.

As an informal illustration of the concept of a fuzzy theorem, let us consider the theorem in elementary geometry which asserts that if  $M_1, M_2$  and  $M_3$  are the midpoints of the sides of a triangle (see Fig. 7), then the lines  $AM_1, BM_2$  and  $CM_3$  intersect at a point.

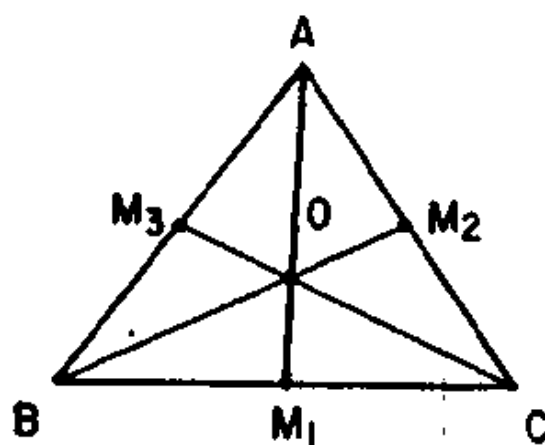

Fig. 7. An elementary theorem in geometry.

**Fuzzy Theorem 2. 1.** *Let  $AB, BC$  and  $CA$  be approximate straight lines which form an approximate equilateral triangle with vertices  $A, B, C$  (see Fig. 8). Let  $M_1, M_2$  and  $M_3$  be approximate midpoints of the sides  $BC, CA$  and  $AB$ , respectively. Then the approximate straight lines  $AM_1, BM_2$  and  $CM_3$  form an approximate triangle  $T_1 T_2 T_3$  which is more or less (more or less small) in relation to  $ABC$ .*

Before we can proceed to “prove” this fuzzy theorem, we must make more specific the sense in which the terms

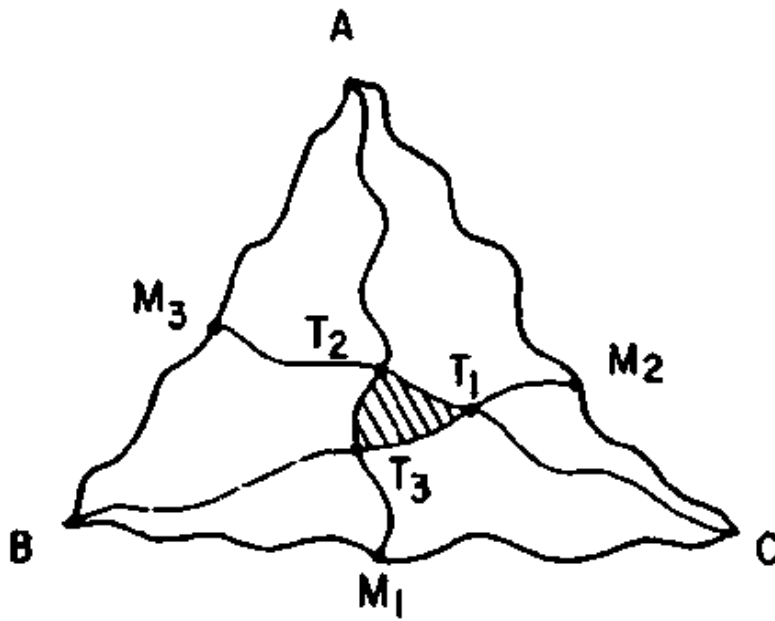

Fig. 8. A fuzzy theorem in geometry.

approximate straight line, approximate midpoint, etc. should be understood. To this end, let us agree that by an *approximate straight line*  $AB$  we mean a curve passing through  $A$  and  $B$  such that the distance of any point on the curve from the straight line  $AB$  is small in relation to the length of  $AB$ . With reference to Fig. 9, this implies that we are assigning a linguistic value *small* to the distance  $d$ , with the understanding that  $d$  is interpreted as a fuzzy variable.

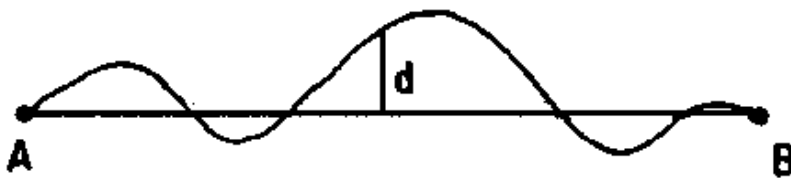

Fig. 9. Definition of *approximately straight line*.



Let  $(AB)^0$  denote the straight line  $AB$ . Then, by an *approximate midpoint* of  $AB$  we mean a point on  $AB$  whose distance from  $M_1^0$ , the midpoint of  $(AB)^0$ , is *small*.

Turning to the statement of the fuzzy theorem, let  $O$  be the intersection of the straight lines  $(AM_1^0)^0$  and  $(BM_2^0)^0$  (Fig. 10). Since  $M_1$  is assumed to be an approximate midpoint of  $BC$ , the distance of  $M_1$  from  $M_1^0$  is *small*. Consequently, the distance of any point on  $(AM_1)^0$  from  $(AM_1^0)^0$  is *small*. Furthermore, since the distance of any point on  $AM_1$  from  $(AM_1)^0$  is *small*, it follows that the distance of any point on  $AM_1$  from  $(AM_1^0)^0$  is *more or less small*.

The same argument applies to the distance of points on  $BM_2$  from  $(BM_2^0)^0$ . Then, taking into consideration that the angle between  $(AM_1)^0$  and  $(BM_2)^0$  is approximately  $120^\circ$ , the distance between an intersection of  $AM_1$  and  $BM_2$  and  $O$  is *(more or less)<sup>2</sup> small* [that is, *more or less (more or less small)*]. From this it follows that the distance of any vertex of the triangle  $T_1 T_2 T_3$  from  $O$  is *(more or less)<sup>2</sup> small*. It is in this sense that the triangle  $T_1 T_2 T_3$  is *(more or less)<sup>2</sup> small* in relation to  $ABC$ .

The reasoning used above is both approximate and qualitative in nature. It uses as its point of departure the fact that  $AM_1, BM_2$  and  $CM_3$  intersect at  $O$ , and employs what, in effect, are qualitative continuity arguments. Clearly, the "proof" would be longer and more involved if we had to start from the basic axioms of Euclidean geometry rather than the nonfuzzy theorem which served as our point of departure.

At this point, what we can say about fuzzy theorems is highly preliminary and incomplete in nature. Nonetheless, it

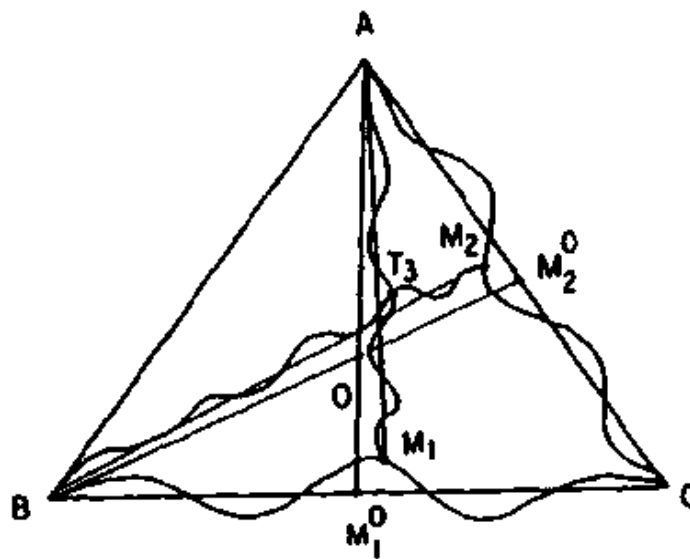

Fig. 10. Illustration of an approximate proof of the fuzzy theorem.

appears to be an intriguing area for further study and eventually may prove to be of use in various types of ill-defined decision processes.

#### *Graphical representation by fuzzy flowcharts*

As pointed out in [7], in the representation and execution of fuzzy algorithms it is frequently very convenient to employ flowcharts for the purpose of defining relations between variables and assigning values to them.

In what follows, we shall not concern ourselves with the many complex issues arising in the representation and execution of fuzzy algorithms. Thus, our limited objective is merely to clarify the role played by the decision boxes which are associated with fuzzy rather than nonfuzzy predicates by relating their function to the assignment of restrictions on base variables.

In the conventional flowchart, a decision box such as  $A$  in

Fig. 11 represents a unary<sup>①</sup> predicate,  $A(x)$ . Thus, transfer from point 1 to point 2 signifies that  $A(x)$  is *true*, while transfer from 1 to 3 signifies that  $A(x)$  is *false*.

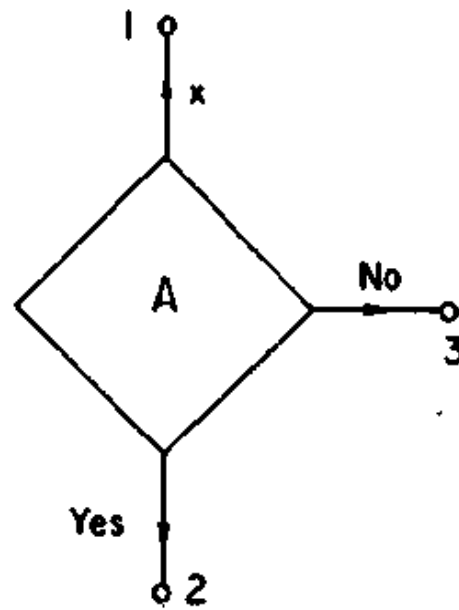

Fig. 11. A fuzzy decision box.

The concepts introduced in the preceding sections provide us with a basis for extending the notion of a decision box to fuzzy sets (or predicates). Specifically, with reference to Fig. 11, suppose that  $A$  is a fuzzy subset of  $U$ , and the question associated with the decision box is: "Is  $x$   $A$ ?" as in "Is  $x$  *small*?" where  $x$  is a generic name for the input variable. Flowcharts containing decision boxes of this type will be referred to as *fuzzy flowcharts*.

If the answer is simply YES, we assign  $A$  to the restriction

---

① For simplicity, we shall not consider decision boxes having more than one input and two outputs.

on  $x$ . That is, we set

$$R(x) = A \quad (2.63)$$

and transfer  $x$  from 1 to 2.

On the other hand, if the answer is NO, we set

$$R(x) = \neg A \quad (2.64)$$

and transfer  $x$  from 1 to 3.

As an illustration, if  $A \triangleq \text{small}$ , then (2.63) would read

$$R(x) = \text{small}. \quad (2.65)$$

If the answer is YES/ $\mu$ , where  $0 \leq \mu \leq 1$ , then we transfer  $x$  to 2 with the conclusion that the grade of membership of  $x$  in  $A$  is  $\mu$ . We also transfer  $x$  to 3 with the conclusion that the grade of membership of  $x$  in  $\neg A$  is  $1-\mu$ .

If the grade of membership,  $\mu$ , is linguistic rather than numerical, we represent it as a linguistic truth-value. Typically, then, the answer would have the form YES/*true* or YES/*very true* or YES/*more or less true*, etc. As before, we conclude that the grade of membership of  $x$  in  $A$  is  $\mu$ , where  $\mu$  is a linguistic truth-value, and transfer  $x$  to 3 with the conclusion that the grade of membership of  $x$  in  $\neg A$  is  $1-\mu$ .

If we have a chain of decision boxes as in Fig. 12, a succession of YES answers would transfer  $x$  from 1 to  $n+1$  and would result in the assignment to  $R(x)$  of the intersection of  $A_1, \dots, A_n$ . Thus,

$$R(x) = A_1 \cap \dots \cap A_n, \quad (2.66)$$

where  $\cap$  denotes the intersection of fuzzy sets. (See also Fig. 13.)

As a simple illustration, suppose that  $x = \text{John}$ ,  $A_1 = \text{tall}$  and

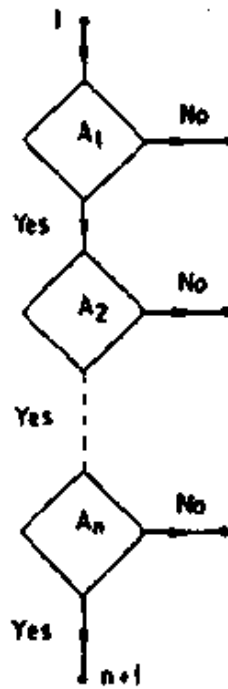

Fig. 12. A tandem combination of decision boxes.

$A_2 = fat$ . Then, if the response to the question "Is John *tall*?" is YES, and the response to "Is John *fat*?" is YES, the restriction imposed by John is expressed by

$$R(\text{John}) = tall \cap fat. \quad (2.67)$$

It should be noted that "John" is actually the name of a binary linguistic variable with two components named *Height* and *Weight*. Thus (2.67) is equivalent to the assignment equations

$$Height = tall \quad (2.68)$$

and

$$Weight = fat. \quad (2.69)$$

As implied by (2.66), a tandem connection of decision boxes represents the intersection of the fuzzy sets (or, equivalently, the

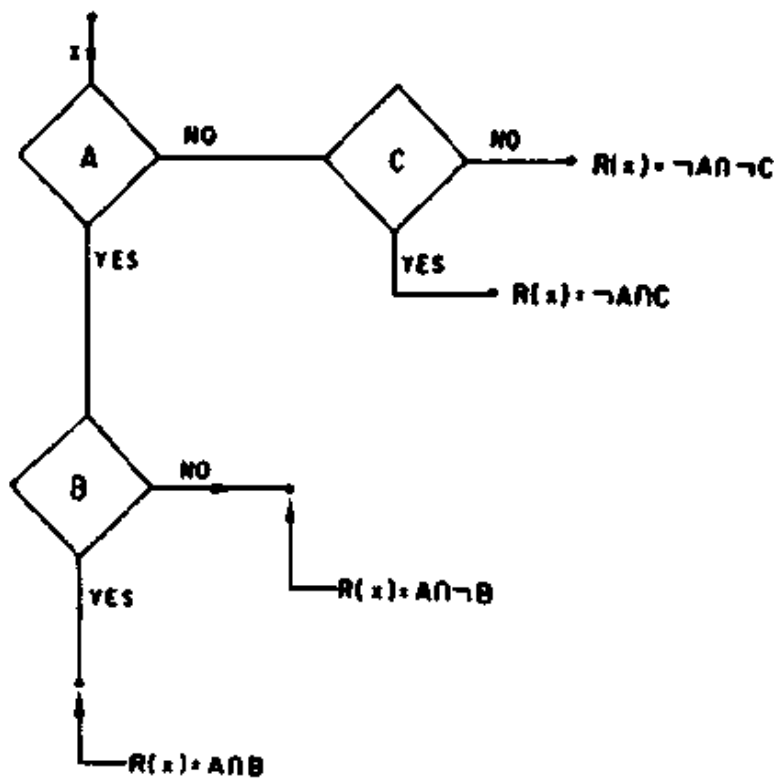

Fig. 13. Restrictions associated with various exits from a fuzzy flowchart.

conjunction of the fuzzy predicates) associated with them. In the case of nonfuzzy sets, their union may be realized by the scheme shown in Fig. 14. In this arrangement of decision boxes, it is clear that transfer from 1 to 2 implies that

$$R(u) = A + \neg A \cap B, \quad (2.70)$$

and since

$$A \cap B \subset A, \quad (2.71)$$

it follows that (2.70) may be rewritten as

$$\begin{aligned} R(u) &= A + A \cap B + \neg A \cap B \\ &= A + (A + \neg A) \cap B \\ &= A + B, \end{aligned} \quad (2.72)$$

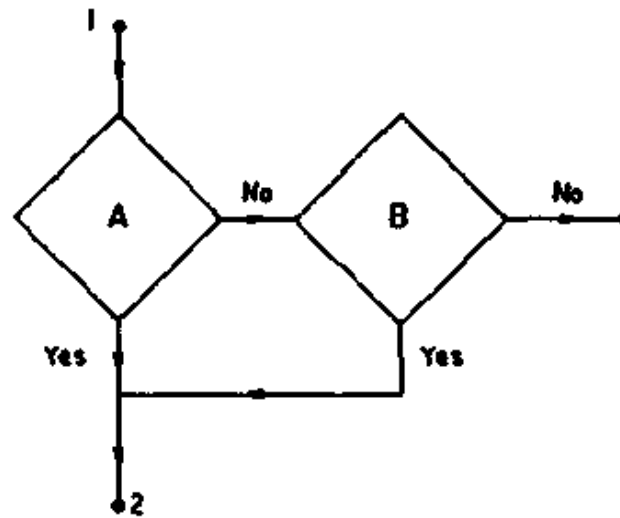

Fig. 14. A graphical representation of the disjunction of fuzzy predicates.

since

$$A + \neg A = U \quad (2.73)$$

and

$$U \cap B = B. \quad (2.74)$$

The same scheme would not yield the union of fuzzy sets, since the identity

$$A + \neg A = U \quad (2.75)$$

does not hold exactly if  $A$  is fuzzy. Nevertheless, we can agree to interpret the arrangement of decision boxes in Fig. 14 as one that represents the union of  $A$  and  $B$ . In this way, we can remain on the familiar ground of flowcharts involving nonfuzzy decision boxes. The flowchart shown in Fig. 16 below illustrates the use of this convention in the definition of *Hippie*.

The conventions described above may be used to represent in a graphical form the assignment of a linguistic value to a linguistic variable. Of particular use in this connection is a

tandem combination of decision boxes which represent a series of *bracketing* questions which are intended to narrow down the range of possible values of a variable. As an illustration, suppose that  $x = \text{John}$  and (see Fig. 15)

$$\begin{aligned} A_1 &= \text{tall}, \\ A_2 &= \text{very tall}, \\ A_3 &= \text{very very tall}, \\ A_4 &= \text{extremely tall}. \end{aligned} \tag{2.76}$$

If the answer to the first question is YES, we have

$$R(x) = \text{tall}. \tag{2.77}$$

If the answer to the second question is YES and to the third question is NO, then

$$R(\text{John}) = \text{very tall and not very very tall}, \tag{2.78}$$

which brackets the height of John between *very tall* and *not very very tall*.

By providing a mechanism—as in bracketing—for assigning linguistic values in stages rather than in one step, fuzzy flowcharts can be very helpful in the representation of algorithmic definitions of fuzzy concepts. The basic idea in this instance is to define a complex or a new fuzzy concept in terms of simpler or more familiar ones. Since a fuzzy concept may be viewed as a name for a fuzzy set, what is involved in this approach is, in effect, the decomposition of a fuzzy set into a combination of simpler fuzzy sets.

As an illustration, suppose that we wish to define the term *Hippie*, which may be viewed as a name of a fuzzy subset of the



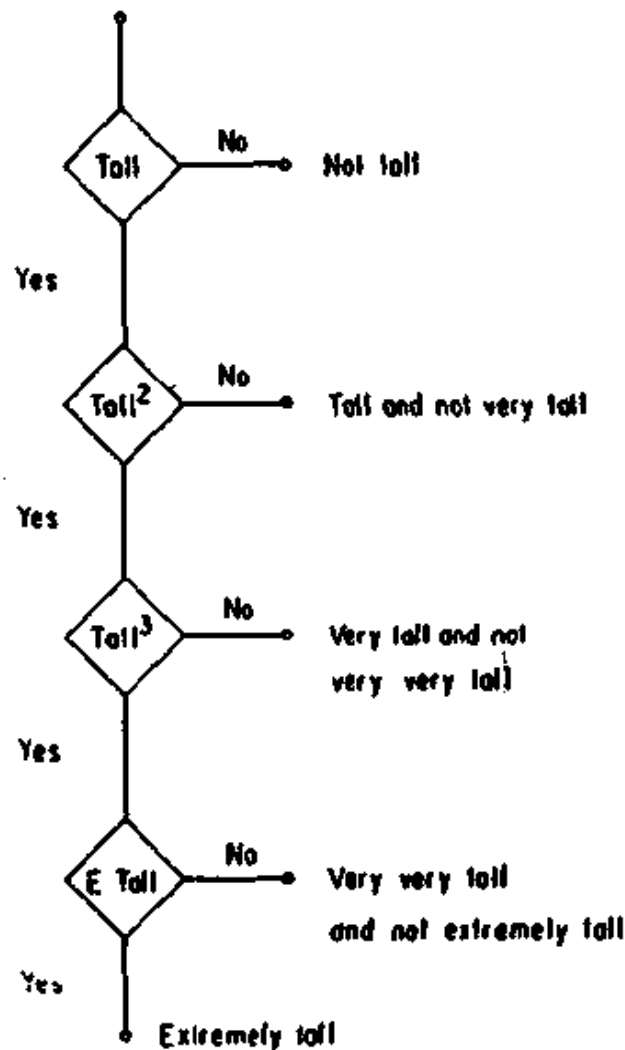

Fig. 15. Use of a tandem combination of decision boxes for purposes of bracketing.

universe of humans. To this end, we employ the fuzzy flowchart<sup>①</sup> shown in Fig. 16. In essence, this flowchart defines the fuzzy set *Hippie* in terms of the fuzzy sets labeled *Long Hair*, *Bald*,

① It should be understood, of course, that this highly oversimplified definition is used merely as an illustration and has no pretense at being accurate, complete or realistic.

*Shaved, Job and Drugs.* More specifically, it defines the fuzzy set *Hippie* as  $(+ \triangleq \text{union})$

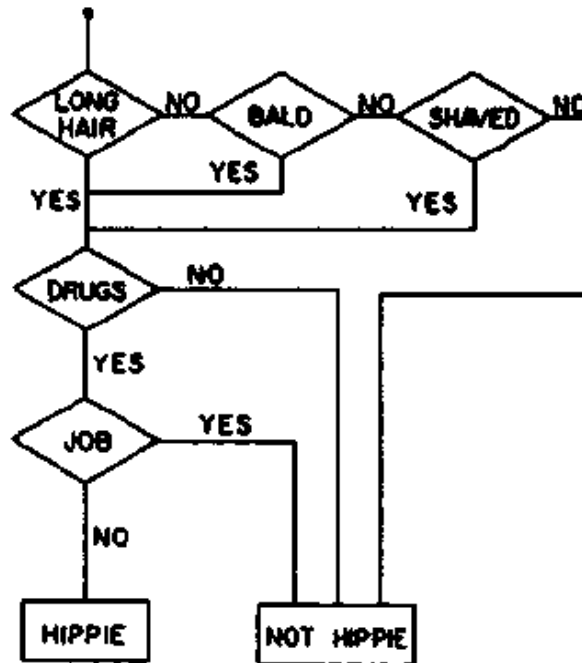

Fig. 16. Algorithmic definition of *Hippie* presented in the form of a fuzzy flowchart.

$$Hippie = (Long\ Hair + Bald + Shaved) \cap Drugs \cap \neg Job \quad (2.79)$$

Suppose that we pose the following questions and receive the indicated answers.

Does $x$ have <i>Long Hair</i>	YES
Does $x$ have a <i>Job</i> ?	NO
Does $x$ take <i>Drugs</i> ?	YES

Then we assign to  $x$  the restriction

$$R(x) = Long\ hair \cap \neg Job \cap Drugs,$$

and since it is contained in the right-hand side of (2.79), we conclude that  $x$  is a *Hippie*.

By modifying the fuzzy sets entering into the definition of *Hippie* through the use of hedges such as *very*, *more or less*, *extremely*, etc. , and by allowing the answers to be of the form YES/ $\mu$  or NO/ $\mu$ , where  $\mu$  is a numerical or linguistic truth-value, the definition of *Hippie* can be adjusted to fit more closely our conception of what we want to define. Furthermore, we may use a soft *and* (see Part I ,Comment 3.1) to allow some trade-offs between the characteristics which define a hippie. And, finally, we may allow our decision boxes to have multiple inputs and multiple outputs. In this way, a concept such as *Hippie* can be defined as completely as one may desire in terms of a set of constituent concepts each of which, in turn, may be defined algorithmically. In essence, then, in employing a fuzzy flowchart to define a fuzzy concept such as *Hippie*, we are decomposing a statement of the general form

$v(u \text{ is ;linguistic value of a Boolean linguistic variable } \mathcal{X}) =$   
linguistic value of a Boolean linguistic truth-variable  $\mathcal{T}$  (2.80)  
into truth-value assignments of the same form, but involving simpler or more familiar variables on the left-hand side of (2.80).

#### *Concluding remarks*

In this as well as in the preceding sections, our main concern has centered on the development of a conceptual framework for what may be called a *linguistic approach* to the analysis of complex or ill-defined systems and decision processes. The substantive differences between this approach and the conventional quantitative techniques of system analysis raise many issues and problems which are novel in nature and hence

require a great deal of additional study and experimentation. This is true, in particular, of some of the basic aspects of the concept of a linguistic variable on which we have dwelt only briefly in our exposition, namely: linguistic approximation, representation of linguistic hedges, nonnumerical base variables,  $\lambda$ -and  $\beta$ -interaction, fuzzy theorems, linguistic probability distributions, fuzzy flowcharts and others.

Although the linguistic approach is orthogonal to what have become the prevailing attitudes in scientific research, it may well prove to be a step in the right direction, that is, in the direction of lesser preoccupation with exact quantitative analyses and greater acceptance of the pervasiveness of imprecision in much of human thinking and perception. It is our belief that, by accepting this reality rather than assuming that the opposite is the case, we are likely to make more real progress in the understanding of the behavior of humanistic systems than is possible within the confines of traditional methods.

## References

- [1] Sir William Thomson, *Popular Lectures and Addresses*, McMillan, London, 1891.
- [2] E. Feigenbaum, *Computers and Thought*, McGraw-Hill, New York, 1963.
- [3] M. Minsky and S. Papert, *Perceptrons: An Introduction to Computational Geometry*, M. I. T. Press, Cambridge, Mass., 1969.
- [4] M. Arbib, *The Metaphorical Brain*, Wiley-Interscience, New York, 1972.

- [5] A. Newell and H. Simon, *Human Problem Solving*, Prentice-Hall, Englewood Cliffs, N. J. ,1972.
- [6] L. A. Zadeh, Fuzzy languages and their relation to human and machine intelligence, in *Proc. Int. Conf. on Man and Computer*, Bordeaux, France, S. Karger, Basel, 1972, pp. 130~165.
- [7] L. A. Zadeh, Outline of a new approach to the analysis of complex systems and decision processes, *IEEE Trans. Syst. , Man and Cybern.* SMC-3, 28~44 (January 1973).
- [8] R. E. Bellman, R. E. Kalaba and L. A. Zadeh, Abstraction and pattern classification, *J. Math. Anal. Appl.* 13, 1~7 (1966).
- [9] M. Black, Reasoning with loose concepts, *Dialogue* 2, 1~12 (1963).
- [10] L. Wittgenstein, Logical form, *Proc. Aristotelian Soc.* 9, 162 ~ 171 (1929).
- [11] M. Scriven, The logic of criteria, *J. Philos.* 56, 857-868 (1959).
- [12] H. Khatchadourian, Vagueness, meaning and absurdity, *Am. Phil. Quart.* 2, 119~129 (1965).
- [13] R. R. Verma, Vagueness and the principle of excluded middle, *Mind* 79, 67~77 (1970).
- [14] J. A. Goguen, The Logic of Inexact Concepts, *Synthese* 19, 325 ~ 373 (1969).
- [15] E. Adams, The logic of "Almost All", *J. Philos. Logic* 3, 3~17 (1974).
- [16] K. Fine, Vagueness, truth and logic, Department of Philosophy, University of Edinburgh, 1973.
- [17] B. S. van Frassen, Presuppositions, supervaluations and free logic, in *The Logical Way of Doing Things* (K. Lambert, Ed. ), Yale U. P. , New Haven, Conn. ,1969.
- [18] G. Lakoff, Linguistics and natural logic, in *Semantics of Natural Languages*, (D. Davidson and G. Harman, Eds. ), D. Reidel, Dordrecht, The Netherlands, 1971.
- [19] L. A. Zadeh, Shadows of fuzzy sets, *Probl. Transfer Inf.* 2, 37 ~ 44 (1966).

- [20] A. Kaufmann, *Theory of Fuzzy Sets*, Masson, Paris, 1972.
- [21] J. Goguen, *L-fuzzy sets*, *J. Math. Anal. Appl.* 18, 145~174(1967).
- [22] J. G. Brown, A note on fuzzy sets, *Inf. Control* 18, 32~39(1971).
- [23] M. Mizumoto, J. Toyoda and K. Tanaka, General formulation of formal grammars, *Inf. Sci.* 4, 87~100, 1972.
- [24] L. A. Zadeh, Similarity relations and fuzzy orderings, *Inf. Sci.* 3, 177~200(1971).
- [25] R. E. Bellman and L. A. Zadeh, Decision-making in a fuzzy environment, *Manage. Sci.* 17, B-141-B-164(1970).
- [26] R. E. Bellman and M. Giertz, On the analytic formalism of the theory of fuzzy sets, *Inf. Sci.* 5, 149~156(1973).
- [27] L. A. Zadeh, A fuzzy-set-theoretic interpretation of linguistic hedges, *J. Cybern.* 2, 4~34(1972).
- [28] E. F. Codd, Relational completeness of data base sublanguages, in *Courant computer Science Symposia*, Vol. 6, Prentice-Hall, Englewood Cliffs, N. J. ,1971.
- [29] L. A. Zadeh, Fuzzy sets, *Inf. Control* 8, 338~353, 1965.
- [30] A. Thomasian, *The Structure of Probability Theory With Applications*, McGraw-Hill, New York, 1969.
- [31] R. E. Moore, *Interval Analysis*, Prentice-Hall, Englewood Cliffs, N. J. , 1966.
- [32] J. A. Brzozowski, Regular expressions for linear sequential circuits, *IEEE Trans. Electron Comput.* ,EC-14, 148~156(1965).
- [33] E. Shamir, Algebraic, Rational and Context-Free Power Series in Noncommuting Variables, in M. Arbib's *Algebraic Theory of Machines, Languages and Semigroups*, Academic, New York, 1968, pp. 329~341.
- [34] A. Blikle, Equational languages, *Inf. Control* 21, 134~147(1972).
- [35] D. J. Rosenkrantz, Matrix equation and normal forms for context-free grammars, *J. Assoc. Comput. Mach.* 14, 501~507, 1967.
- [36] J. E. Hopcroft and J. D. Ullman, *Formal Languages and Their Relations*

- to Automata, Addison-Wesley, Reading, Mass., 1969.
- [37] A. V. Aho and J. D. Ullman, *The Theory of Parsing, Translation and Compiling*, Prentice-Hall, Englewood Cliffs, N. J., 1973.
- [38] G. Lakoff, Hedges; a study in meaning criteria and the logic of fuzzy concepts, in *Proc. 8th Reg. Meeting of Chic. Linguist. Soc.* Univ. of Chicago Linguistics Dept., April 1972.
- [39] L. A. Zadeh, Quantitative fuzzy semantics, *Inf. Sci.* 3, 159~176(1971).
- [40] D. Knuth, Semantics of context-free languages, *Math. Syst. Theory*, 2, 127~145(1968).
- [41] P. Lucas et al., Method and notation for the formal definition of programming languages, Rept. TR 25.087, IBM Laboratory, Vienna, 1968.
- [42] P. Wegner, The Vienna definition language, *ACM Comput. Surv.* 4, 5~63, (1972).
- [43] J. A. Lee, *Computer Semantics*, Van Nostrand-Reinhold, New York, 1972.
- [44] Z. Kohavi, *Switching and Finite Automata Theory*, McGraw-Hill, New York, 1970.
- [45] G. E. Hughes and M. J. Cresswell, *An Introduction to Modal Logic*, Methuen, London, 1968.
- [46] N. Rescher, *Many-Valued Logic*, McGraw-Hill, New York, 1969.
- [47] R. Barkan, A functional calculus of first order based on strict implication, *J. Symbol. Logic* 11, 1~16(1946).
- [48] L. A. Zadeh, Probability measures of fuzzy events, *J. Math. Anal. Appl.* 23, 421~427(1968).
- [49] A. DeLuca and S. Termini, A definition of non-probabilistic entropy in the setting of fuzzy set theory, *Inf. Control* 20, 201~312(1972).
- [50] J. Hintikka and P. Suppes (Eds.), *Aspects of Inductive Logic*, North-Holland, Amsterdam, 1966.
- [51] T. Winograd, *Understanding Natural Language*, Academic, New York, 1972.

- [52] A. DeLuca and S. Termini, Algebraic properties of fuzzy sets, *J. Math. Anal. Appl.* 40, 373~386(1972).
- [53] A. Rosenfeld, Fuzzy groups, *J. Math. Anal. Appl.* 35, 512-517(1971).
- [54] L. A. Zadeh, Fuzzy Algorithms, *Inf. Control* 12, 94~102(1968).
- [55] E. Santos, Fuzzy algorithms, *Inf. Control* 17, 326~339(1970).
- [56] S. K. Chang, On the execution of fuzzy programs using finite state machines, *IEEE Trans. Electron. Comput.*, C-21, 241~253(1972).
- [57] S. S. L. Chang and L. A. Zadeh, Fuzzy mapping and control, *IEEE Trans. Syst., Man and Cybern.*, SMC-2, 30~34(1972).
- [58] E. T. Lee, Fuzzy languages and their relation to automata, Dissertation, Dept. of Electr. Eng. and Comput. Sci., Univ. of Calif., Berkeley, 1972.
- [59] R. C. T. Lee, Fuzzy logic and the resolution principle, *J. Assoc. Comput. Mach.* 19, 109~119(1972).
- [60] K. M. Colby, S. Weber and F. D. Hill, Artificial paranoia, *J. Artif. Intell.* 2, 1~25(1971).



Part 4: Fuzzy-algorithmic  
approach and information  
granularity



# **A Fuzzy-Algorithmic Approach to the Definition of Complex or Imprecise Concepts**

## **1. Introduction**

The high standards of precision which prevail in mathematics, physics, chemistry, engineering and other "hard" sciences stand in sharp contrast to the imprecision which pervades much of sociology, psychology, political science, history, philosophy, linguistics, anthropology, literature, art and related fields. This marked difference in the standards of precision is due, of course, to the fact that the "hard" sciences are concerned in the main with the relatively simple mechanistic systems whose behavior can be described in quantitative terms, whereas the "soft" sciences deal primarily with the much more complex non-mechanistic systems in which human judgment, perception and emotions play the dominant role.

Although the conventional mathematical techniques have been and will continue to be applied to the analysis of humanistic<sup>①</sup> systems, it is clear that the great complexity of such systems calls for approaches that are significantly different in

---

① By a humanistic system we mean a non-mechanistic system in which human behavior plays a major role. Examples of humanistic systems are political systems, economic systems, social systems, religious systems, etc. A single individual and his thought processes may also be viewed as a humanistic system.

spirit as well as in substance from the traditional methods — methods which are highly effective when applied to mechanistic systems, but are far too precise in relation to systems in which human behavior plays an important role.

In the *linguistic approach* (Zadeh, 1973, 1975a) which represents one such departure from conventional methods — words or sentences are used in place of numbers to describe phenomena which are too complex or too ill-defined to be susceptible of characterization in quantitative terms. For example, if the probability of an event is not known with precision, then it may be characterized linguistically as, say, *quite likely*, *not very unlikely*, *highly unlikely*, etc., where *quite likely*, *not very unlikely* and *highly unlikely* are interpreted as labels of fuzzy subsets of the unit interval. <sup>①</sup> Such subsets may be likened to ball-parks without sharply defined boundaries which serve to provide an approximate rather than exact characterization of the value of a variable.

The use of the linguistic approach in the case of humanistic systems is dictated by the fact that as the complexity of a system increases, our ability to make precise and yet significant statements about its behavior diminishes until a threshold is reached beyond which complexity, precision and significance can no longer coexist. The essence of the linguistic approach, then, is

---

<sup>①</sup> As a fuzzy subset of the unit interval, *quite likely* would be characterized by its compatibility or, equivalently, membership function  $\mu_{\text{quite likely}}: [0, 1] \rightarrow [0, 1]$ . Thus,  $\mu_{\text{quite likely}}(0.8) = 0.9$  means that if the probability of an event is 0.8, then the degree to which 0.8 is compatible with *quite likely* is 0.9. Additional details may be found in the Appendix.

that it sacrifices precision to gain significance, thereby making it possible to analyze in an approximate manner those humanistic as well as mechanistic systems which are too complex for the application of classical techniques.

A key feature of the linguistic approach has to do with its use of the notion of a *primary fuzzy set* as a substitute for the basic notion of a *unit of measurement*<sup>①</sup> More specifically, much of the power of mathematical techniques for dealing with mechanistic systems derives from the existence of a set of units for such basic parameters as length, area, weight, force, current, heat, etc. In general, such units do not exist in the case of humanistic systems, and it is this fact that contributes significantly to the difficulty of analyzing humanistic systems through the use of techniques which depend so essentially on the existence of units of measurement.

In the linguistic approach, a role comparable to that of a unit of measurement is played by one or more primary fuzzy sets from which other sets can be generated through the use of linguistic modifiers such as *very, quite, more or less, extremely, essentially, completely*, etc. To illustrate, consider a property,<sup>②</sup> say *beautiful*,

---

① A thorough discussion of the concept of a unit of measurement may be found in Krantz, Luce, Suppes & Twersky (1971).

② At this point we do not differentiate between a property (intension) and the set which it defines (extension). For a discussion of this and other issues relating to concepts, meaning and vagueness see: Carnap (1956), Hempel (1952), Church (1951), Quine (1953), Frege (1952), Martin (1963), Black (1963), Goguen (1969), Fine (1973), van Frassen (1969), Lakoff (1971), Tarski (1956), Scriven (1958), Simon & Siklossy (1972), Hintikka, Moravcsik & Suppes (1973), Minsky (1968), Lukasiewicz (1970), Moisl (1972), and Domotor (1969).

for which we have neither a unit nor a numerical scale. The meaning of this property may be defined via *exemplification* by associating with each member,  $u$ , of a subset of objects in a given universe of discourse,  $U$ , the grade of membership of  $u$  in the fuzzy subset labeled *beautiful*. For example, the grade of membership of Fay in the class of beautiful women might be 0.9, that of Jillian 0.85, of Helen 0.8, etc. This set of women, then, would constitute a primary fuzzy set which serves as a reference for defining the meaning of *very beautiful*, *quite beautiful*, *more or less beautiful*, *extremely beautiful*, etc. as fuzzy subsets of  $U$ .<sup>①</sup> Thus, in terms of these subsets, an assertion of the form "*Nora is very beautiful*", may be interpreted as the assignment of a linguistic rather than a numerical value to the beauty of Nora. In this way, the linguistic values *beautiful*, *very beautiful*, *quite beautiful*, etc. which are generated from the primary fuzzy set *beautiful*, play a role which is roughly similar to that of the multiples of a unit of measurement, when such a unit exists.

Our main purpose in the present paper is to apply the linguistic approach to the definition of concepts which are too complex or too imprecise to be susceptible of exact definition. In general, such concepts are fuzzy in the sense that they correspond to classes of objects or constructs which do not have sharply defined boundaries. For example, the concepts of *oval*, *in love*, *young* and *masculine* are fuzzy whereas those of *straight line*,

---

① The computation of the meaning of a term of the form  $mu$ , where  $m$  is a modifier and  $u$  is a primary term (i. e. a label for a primary fuzzy set) is discussed in Zadeh (1972a, b), Lakoff (1972), and more briefly, in the Appendix.

*married*, *brother* and *male* are not. Note that *oval* is a more complex concept than *straight line*, *in love* is more complex than *married*, *friend* is more complex than *brother*, and *masculine* is more complex than *male*. Indeed, most complex concepts tend to be fuzzy, and it is in this sense that fuzziness may be regarded as a concomitant of complexity.

*Note 1. 1.* In most cases, the question of whether a concept is fuzzy or not may be resolved by examining the applicability of a simple modifier such as *very* to the concept in question. Thus, for example, *very* is applicable to *masculine* but not to *male*. Similarly, *very ill*, where *ill* is a fuzzy concept, is acceptable, whereas *very dead* is not. Also, *very much greater* is acceptable (*much greater* is fuzzy), while *very greater* (*greater* is non-fuzzy) is not.

How can a fuzzy concept be defined? The conventional approaches are : (a) giving a dictionary type of definition; (b) writing an essay; and (c) approximating to a fuzzy concept by a non-fuzzy concept and giving a precise definition for the latter. To illustrate, a typical dictionary definition of a fuzzy concept such as *democracy* might read, "A form of government in which the supreme power is vested in the people and exercised by them or by their elected agents under a free electoral system," while a more detailed definition might occupy a chapter in a text on political science. A typical example of (c) is the definition of a *recession* (Silk, 1974; Clark, 1974) as a condition which obtains when the gross national product declines in two successive quarters. In this case, what is in reality a fuzzy concept is defined as one which is both non-fuzzy and simple to understand. The

price, of course, is a definition that is oversimplified to a point of uselessness.

An alternative and more systematic approach which is described in the sequel is based on the notion of a fuzzy algorithm (Zadeh, 1968; Santos, 1970; Zadeh, 1971a), that is, an algorithm (or a program or a decision table) in which some of the steps involve the execution of fuzzy instructions, which in turn may require the verification of fuzzy conditions. More specifically, in the *fuzzy-algorithmic* approach the definition of a fuzzy concept  $F$  is expressed as a fuzzy recognition algorithm<sup>①</sup> which acts on a given object  $u$  and upon execution yields the degree to which  $u$  is compatible with  $F$  or, equivalently, the grade of membership of  $u$  in the fuzzy set labeled  $F$ .

As an illustration, suppose that the concept of an economic recession is defined by a fuzzy algorithm labeled RECESSION. Then, acting on relevant economic data, RECESSION would yield the degree—expressed numerically, e. g., 0.8, or linguistically, e. g., *very true*—to which the data in question are compatible with the concept of *recession* as defined by the algorithm. Similarly, a fuzzy-algorithmic definition of a disease, say *arthritis*, would yield the degree to which a given patient belongs to the class of arthritics. Similarly, a fuzzy-algorithmic definition of the concept of *sparseness* would yield the degree to which a given matrix is sparse. And so on.

As will be seen in the following sections, a fuzzy-algorithmic

---

① A recognition algorithm is essentially an algorithmic representation of the membership function of a fuzzy set.



definition has the form of a branching questionnaire,  $Q$ , in which both the questions and the answers are allowed to be fuzzy in nature. For example, to a question such as "Is Valentina *tall*?" (which will be abbreviated as *tall*?) the answer might be "*quite tall*", which may be viewed as being equivalent to the assignment of the linguistic value *quite high* to the grade of membership of Valentina in the class of tall people.

A question,  $Q_i$ , in  $Q$  may be either *classificational* or *attributinal*. In the case of classificational questions,  $Q_i$  is concerned with the grade of membership of the subject in a fuzzy set  $F_i$ , or, equivalently, with the truth-value of the predicate<sup>①</sup> which corresponds to  $F_i$ . For example,  $Q_i$  may be "Is Rahim *honest*?" An answer such as *very high* would mean that the grade of membership of the subject in the class of *honest* people is *very high*. Equivalently, an answer of the form *very true* would be interpreted as the assignment of the truth-value *very true* to the predicate labeled *honest* evaluated at  $x \triangleq \text{Rahim}$ .<sup>②</sup>

In the case of attributinal questions,  $Q_i$  relates to the value of an attribute of the subject. For example, an instance of  $Q_i$  may be "How *old* is Norman?" with the answer being either numerical, e. g. 24 or linguistic, e. g. *quite young*. Thus, in this case the answer may be viewed as the assignment of either a numerical or

---

① The term *predicate* (or, more generally, *fuzzy predicate*) as used here is essentially synonymous with the *membership* (or *compatibility*) *function*. To simplify the notation, the label of a predicate and the label of the set which it defines will be used interchangeably.

② The symbol  $\triangleq$  stands for *denotes* or *is defined to be* or *is equal by definition*.

a linguistic value to an attribute of the subject.

The totality of the questions in  $Q$  constitutes a *basis* for  $Q$ , or, more specifically, the fuzzy concept defined by  $Q$ . If all of the questions in  $Q$  are classificational in nature, then the basis for  $Q$  defines a collection of fuzzy sets each of which corresponds to a question in  $Q$ . In this case, the questionnaire may be viewed as a way of defining the fuzzy set corresponding to  $Q$  in terms of the fuzzy sets corresponding to the questions in  $Q$ . As a simple illustration, if the predicate *big* is defined as the conjunction of the predicates *long*, *wide*, and *tall*, i. e. ,

$$big = long \text{ and } wide \text{ and } tall \quad (1.2)$$

then  $Q_1, Q_2$  and  $Q_3$  may be expressed (in abbreviated form) as

$$Q_1 \triangleq long? \quad (1.3)$$

$$Q_2 \triangleq wide? \quad (1.4)$$

$$Q_3 \triangleq tall? \quad (1.5)$$

and (1.2) is equivalent to

$$big = long \cap wide \cap tall \quad (1.6)$$

where *big*, *long*, *wide* and *tall* are interpreted as the fuzzy sets corresponding to  $Q, Q_1, Q_2$  and  $Q_3$ , respectively, and the intersection is defined in the fuzzy-set-theoretic sense. Thus, (1.6) expresses the fuzzy set *big* as a function of the fuzzy sets *long*, *wide* and *tall*, which implies that from the knowledge of the answers to  $Q_1, Q_2$  and  $Q_3$  one can determine the grade of membership of the object under test in the fuzzy set *big*. For example, if the answers to specific instances of  $Q_1, Q_2$  and  $Q_3$  are *true*, *very true* and *very true*, respectively, then from (1.6) it follows that the answer to the question *big?* is *true*. A more

detailed discussion of this aspect of fuzzy-algorithmic definitions will be presented in section 3.

By their nature, fuzzy-algorithmic definitions are best suited for the characterization of concepts which are *intrinsically fuzzy*, that is, fuzzy to a degree which makes it unrealistic to approximate to them by non-fuzzy concepts. For example, in law, *insanity* and *obscenity* are intrinsically fuzzy concepts whereas *perjury* is not. Similarly, in system theory the concepts of *large-scale*, *reliable* and *adaptive* are intrinsically fuzzy, whereas those of *observability* and *controllability* are not. In numerical analysis, the concept of a *sparse* matrix is intrinsically fuzzy while that of a *bounded error* is not. In medicine, most degenerative diseases are intrinsically fuzzy while the infectious diseases, for the most part, are not.

In addition to the intrinsically fuzzy concepts, there are many concepts in various fields which though fuzzy in nature are at present defined in non-fuzzy terms, largely because of a lack of alternative modes of definition. This is true, for example, of the concepts of *recession* and *equilibrium* in economics; *complexity* and *approximation* in mathematics; *structured programming* and *correctness* in computer science; *stability* and *linearity* in system theory; *arthritis* and *hypertension* in medicine, etc. It is very likely that, in time, the use of fuzzy-algorithmic techniques for the characterization of such concepts will become a fairly common practice.

In what follows, our discussion of fuzzy-algorithmic definitions will begin with the notion of an *atomic* question. This notion will serve as a basis for the definition of a *composite*

question, which in turn will lead to the concept of a fuzzy-algorithmic *branching questionnaire*. In order to make the discussion self-contained, a brief summary of the relevant aspects of the linguistic approach is presented in the Appendix.

## 2. Atomic questions

Our focus of attention in this section is the concept of what might be called an *atomic* question, that is, a question which has no constituents other than itself. By contrast, a *composite* question — as its name implies — is composed of a collection of constituent questions. The manner in which the constituent questions are combined to form a composite question as well as other issues relating to the concept of a composite question will be discussed in section 3.

*Example 2.1.* The question  $Q \triangleq$  Is Ruth tall? is an atomic question if no other questions have to be asked in order to answer  $Q$ .

The question  $Q \triangleq$  Is  $x$  big? where  $x$  is some object, is a composite question if *big* is defined as the conjunction of *long*, *wide* and *high* (as in (1.2)), and the answer to  $Q$  is deduced from the answers to the constituent questions  $Q_1 \triangleq$  Is  $x$  long?,  $Q_2 \triangleq$  Is  $x$  wide?, and  $Q_3 \triangleq$  Is  $x$  high?

A *questionnaire* is, in effect, a representation of a composite question, and a *branching questionnaire* is a representation in which the order in which the constituent questions are asked is determined by the answers to the previous questions.

In what follows, we shall examine the concept of an atomic question in greater detail with a view to providing a basis for a systematic representation of fuzzy-algorithmic definitions in the form of branching questionnaires.

## NOTATION AND TERMINOLOGY

*Definition 2.2.* An atomic question,  $Q$ , is characterized by a triple  $Q \triangleq (X, B, A)$ , where  $X$ , the *object-set*, is a set of objects to which  $Q$  applies;  $B$ , the *body*, of  $Q$ , is a label of either a class or an attribute; and  $A$ , the *answer-set*, is a set of admissible answers to the question. Where necessary, specific instances of  $Q$ ,  $X$  and  $A$  will be denoted generically by  $q$ ,  $x$  and  $a$ , respectively.<sup>①</sup> When  $X$  and  $A$  are implied,  $Q$  will be written in an abbreviated form as

$$Q \triangleq B?$$

and a specific question together with an admissible answer to it will be expressed as

$$Q/A \triangleq B? a \quad (2.3)$$

or equivalently

$$q/a \triangleq B? a.$$

The pair  $Q/A$  will be referred to as a *question/answer pair* (or simply *Q/A pair*). Graphically, an atomic question (with implied  $x$ ) will be represented in the form of a fan as shown in Fig. 1.

*Example 2.4.* Consider a specific instance of a question  $Q$ , e.g. "Is Nancy well-dressed?" In this case, with the subject  $x$

---

① To avoid a proliferation of symbols,  $Q$  and  $q$  will be used interchangeably when no confusion is likely to arise.

$\triangleq$ Nancy implied, the specific question may be expressed as

$$q \triangleq \text{well-dressed?} \quad (2.5)$$

where *well-dressed* is the body of Q. Correspondingly, a specific Q/A pair might be

$$q/a \triangleq \text{well-dressed? true} \quad (2.6)$$

in which *true*, as an admissible answer, is an element of the answer-set A. If the other elements of the answer-set are *false* and *borderline*, then A may be expressed as

$$A = \text{true} + \text{borderline} + \text{false} \quad (2.7)$$

where + denotes the union rather than the arithmetic sum.

The linguistic truth-values in (2.8) are, in effect, names of fuzzy subsets of the unit interval (Zadeh, 1975*b, c*). In terms of their respective membership functions, these subsets may be expressed as (see the Appendix)

$$\text{true} = \int_0^1 \mu_t(v)/v \quad (2.8)$$

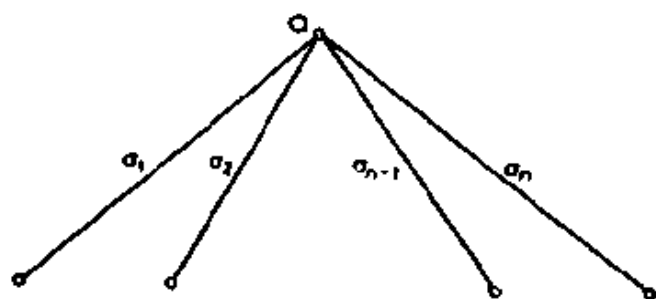

Fig. 1. Graphical representation of an atomic question.

$$\text{borderline} = \int_0^1 \mu_b(v)/v \quad (2.9)$$

and

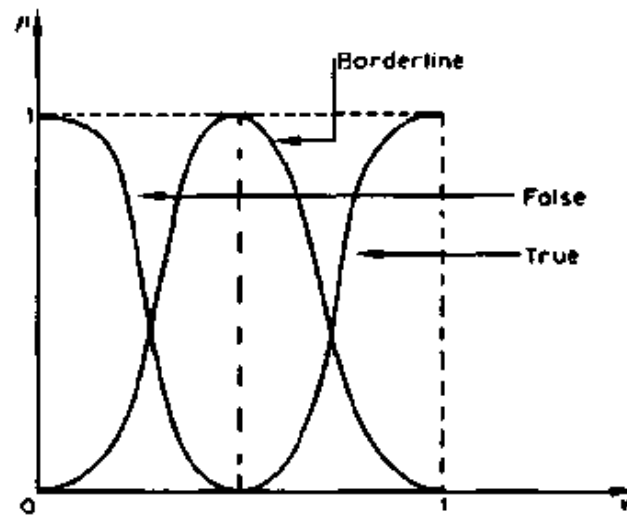

Fig. 2. Membership functions of *true*, *borderline* and *false*.

$$false = \int_0^1 \mu_f(v)/v \quad (2.10)$$

where  $\mu_t$ ,  $\mu_b$  and  $\mu_f$  are the membership functions of *true*, *borderline* and *false*, respectively, and an expression such as (2.8) means that the fuzzy set labeled *true* is the union of fuzzy singletons  $\mu_t(v)/v$  in which the point  $v$  in  $[0, 1]$  has the grade of membership  $\mu_t(v)$  in *true*. Typical forms of  $\mu_t$ ,  $\mu_b$  and  $\mu_f$  are shown in Fig. 2.

*Note 2.11.* For the representation of  $\mu_t$ ,  $\mu_b$  and  $\mu_f$  it is frequently convenient to employ standardized functions with adjustable parameters, e. g., the S and  $\Pi$  functions which are defined below (see Figs 3(a) and 3(b)).

$$\begin{aligned} S(v; \alpha, \beta, \gamma) &= 0 \text{ for } v \leq \alpha & (2.12) \\ &= 2 \left( \frac{v - \alpha}{\gamma - \alpha} \right)^2 \text{ for } \alpha \leq v \leq \beta \\ &= 1 - 2 \left( \frac{v - \gamma}{\gamma - \alpha} \right)^2 \text{ for } \beta \leq v \leq \gamma \\ &= 1 \text{ for } v \geq \gamma \end{aligned}$$

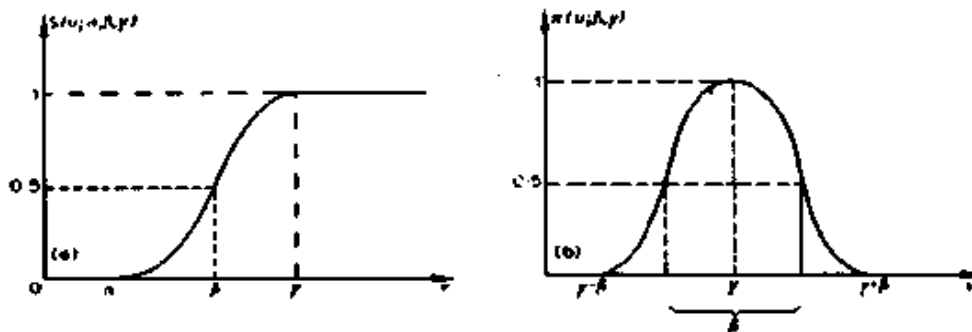

Fig. 3. Plots of S and  $\pi$  functions.

$$\begin{aligned} \pi(v; \beta, \gamma) &= S\left(v; \gamma - \beta, \gamma - \frac{\beta}{2}, \gamma\right) \text{ for } v \leq \gamma & (2.13) \\ &= 1 - S\left(v; \gamma, \gamma + \frac{\beta}{2}, \gamma + \beta\right) \text{ for } v \geq \gamma. \end{aligned}$$

In  $S(v; \alpha, \beta, \gamma)$ , the parameter  $\beta$ ,  $\beta = (\alpha + \gamma)/2$ , is the *crossover point*, that is, the value of  $v$  at which  $S$  takes the value 0.5. In  $\Pi(v; \beta, \gamma)$ ,  $\beta$  is the *bandwidth*, that is, the distance between the crossover points of  $\Pi$ , while  $\gamma$  is the point at which  $\Pi$  is unity.

In terms of  $S$  and  $\Pi$ ,  $\mu_t$ ,  $\mu_b$  and  $\mu_f$  may be expressed as (suppressing the argument  $v$ )

$$\mu_t = S(\alpha, \beta, 1) \quad (2.14)$$

$$\mu_b = \Pi(\beta', 0.5) \quad (2.15)$$

$$\mu_f = 1 - S(0, \beta, \gamma) \quad (2.16)$$

where the use of the symbol  $\beta'$  in (2.15) signifies that the bandwidth of  $b$  need not be equal to the value of  $\beta$  in (2.14).

*Note 2.17.* In cases in which the three linguistic truth-values *true*, *borderline* and *false* do not offer a sufficiently wide choice, it may be convenient to use, in addition, the truth-values *rather true*



and *rather false*, abbreviated as *rt* and *rf*, respectively.

As a fuzzy subset of  $[0, 1]$ , *rather true* may be defined approximately as

*rather true*  $\triangleq$  *not very true and not (false or borderline)*

and its membership function may be approximated by a  $\Pi$  function with  $\gamma$  at, say, the crossover point of *very true*. *Rather false* may be defined similarly in terms of *false* and *borderline*.

## CLASSIFICATIONAL AND ATTRIBUTIONAL QUESTIONS

A question,  $Q$ , is *classificational* if its body,  $B$ , is the label of a fuzzy or non-fuzzy set.

A question,  $Q$ , is *attributitional* if  $B$  is the label of an attribute. In the case of a classificational question, an answer,  $a$  represents the grade of membership of  $x$  in the fuzzy set  $B$ . The answer might be numerical, e. g.,  $a \triangleq 0.8$ , or linguistic, e. g.,  $a \triangleq$  *high*. Equivalently, the answer may be expressed as the truth-value of the predicate  $B(x)$ ,<sup>①</sup> e. g., *true*, *borderline*, *false*, *very true*, etc.

In the case of an attributitional question,  $Q=B?$ , an answer,  $a$ , represents the value of the attribute,  $B$ , of an object  $x$ , e. g.  $B \triangleq$  *age* and  $x \triangleq$  *Haydee*. Again,  $a$  may be numerical, e. g.  $a \triangleq 35$ , or linguistic, e. g.  $a \triangleq$  *young*,  $a \triangleq$  *very young*, etc.

*Comment 2.18.* As defined above, a question  $Q = (X, B, A)$

---

<sup>①</sup> Depending on the circumstances, the arguments of a predicate may be displayed, as in  $B(x)$ , or suppressed, as in  $B$ .

may be viewed as a collection of variables  $\{B(x)\}$ ,  $x \in X$ . From this point of view, answering a classificational question addressed to an  $x$  in  $X$  corresponds to assigning a value, at  $x$ , to the membership function of the fuzzy set  $B$  (or, equivalently, assigning a truth-value to the fuzzy predicate  $B(x)$ ). Similarly, answering an attributional question may be interpreted as the assignment of a value to the attribute  $B(x)$ . In either case, answering a question with body  $B$  may be represented as an assignment equation

$$B(x) = a$$

in which a numerical or a linguistic value  $a$  is assigned to the variable  $B(x)$ .

*Example 2.19.* Suppose that  $X$  is the set of objects in a room and  $Q = \text{red?}$  is a fuzzy classificational question. Furthermore, suppose that the set of admissible answers is the interval  $[0, 1]$ , representing the grades of membership of objects in  $X$  in the fuzzy subset *red* of  $X$ . In this case, an answer such as *true* 0.8 to the question "Is the vase *red*?" may be represented as the assignment equation

$$\text{red}(\text{vase}) = 0.8$$

which implies that the truth-value of the predicate  $\text{red}(x)$  evaluated at  $x \stackrel{\Delta}{=} \text{vase}$  is 0.8 or, equivalently, that the grade of membership of the object  $x \stackrel{\Delta}{=} \text{vase}$  in the fuzzy set labeled *red* is 0.8.

*Example 2.20.* Same as Example 2.19 except that the set of admissible answers,  $A$ , is assumed to be expressed by

$$A = \text{low} + \text{low}^2 + \text{low}^{1/2} + \text{medium} + \text{medium}^2 + \text{medium}^{1/2} +$$

$$high + high^2 + high^{1/2} \quad (2.21)$$

where *high* and *medium* and *low* are primary fuzzy subsets of the unit interval which are defined in terms of the S and  $\Pi$  functions by (2.14), (2.15) and (2.16), and  $w^2$  and  $w^{1/2}$  are abbreviations for *very w* and *more or less w*, respectively. Thus, if  $w$  is a subset of a universe of discourse U, then

$$w^2 = \int_U (\mu_w(u))^2 / u \quad (2.22)$$

and

$$w^{1/2} = \int_U (\mu_w(u))^{1/2} / u, \quad (2.23)$$

which means that the membership functions of  $w^2$  and  $w^{1/2}$  are equal, respectively, to the square and square root of the membership function of  $w$ .

*Example 2.24.* Same as Example 2.19, but with the question assumed to be worded as "Is it true that  $x$  is *red*?" and the set of admissible answers expressed by

$$A = true + true^2 + true^{1/2} + false + false^2 + false^{1/2} + \\ borderline + borderline^2 + borderline^{1/2} \quad (2.25)$$

where *true*, *false* and *borderline* are defined in the same way as *high*, *low* and *medium* and may be used in the same manner. Thus, for example, if the answer to the question "Is it true that the vase is *red*?" is  $true^2$  ( $\triangleq$  *very true*), then the grade of membership of the vase in the class of red objects is given by the assignment equation.

$$\mu_{red}(vase) = true^2 \quad (2.26)$$

where the right-hand member of (2.26) represents a linguistic truth-value whose meaning is defined by (2.22), and the left-

hand member is the membership function of the fuzzy set *red* evaluated at  $x \triangleq$  vase.

*Example 2.27.* As an illustration of an attributional question, suppose that  $X$  is the set of employees in a company and  $Q \triangleq$  *age?* is an attributional question (e. g. "What is the *age* of Elizabeth?"). If the set of admissible answers is the set of integers

$$A = 20 + 21 + \dots + 60 \quad (2.27)$$

then the answer to the question "What is the *age* of Elizabeth?" might be

$$\text{age}(\text{Elizabeth}) = 32$$

On the other hand, if the admissible answers are linguistic in nature, e. g. ,

$$A = \text{young} + \text{not young} + \text{very young} + \text{not very young} + \text{old} + \text{very old} + \dots \quad (2.28)$$

then an answer might have the form

$$\text{age}(\text{Elizabeth}) = \text{very young}$$

with the understanding that *very young* is a linguistic value which is assigned to the linguistic variable *age* (Elizabeth). It should be noted that in (2.28) *young* and *old* play the role of primary fuzzy sets which have a specified meaning, e. g.

$$\mu_{\text{young}} = 1 - S(20, 30, 40) \quad (2.29)$$

$$\mu_{\text{old}} = S(50, 60, 70) \quad (2.30)$$

where the  $S$  and  $\Pi$  functions are defined by (2.12) and (2.13), and  $\mu_{\text{young}}$  and  $\mu_{\text{old}}$  denote the membership functions of *young* and *old*, respectively. The meaning of the other terms in (2.28) may be computed from the definitions of the modifiers *not* and *very*.

Thus,

$$\mu_{\text{not young}} = 1 - \mu_{\text{young}} \quad (2.31)$$

$$\mu_{\text{very young}} = (\mu_{\text{young}})^2 \quad (2.32)$$

$$\mu_{\text{not very young}} = 1 - (\mu_{\text{young}})^2 \quad (2.33)$$

and so on. Note that A may be viewed, in effect, as a microlanguage with its own syntax and semantics.

### NESTED QUESTIONS

Consider an attributional question of the form "How *old* is Françoise?" to which a linguistic answer might be, "Françoise is *young*", with *young* defined by (2.29).

At this point, one could ask a classificational question concerning the answer "Françoise is *young*", namely, "Is it true that (Françoise is *young*)?" to which a linguistic answer might be *very true*. Continuing this process, one could ask the question "Is it true that ((Françoise is *young*) is *very true*)?" to which a linguistic answer might be *more or less true*. On further repetition, we are led to a *nested question* which, in general terms, may be expressed as

$$\text{Is it true that } (\dots(((x \text{ is } w) \text{ is } \tau_1) \text{ is } \tau_2) \dots \text{ is } \tau_n)? \quad (2.34)$$

in which  $w$  is an attribute-value and  $\tau_1, \tau_2, \dots, \tau_n$  are numerical or linguistic truth-values.

How should the meaning of an answer of the form

$$a \stackrel{\Delta}{=} (\dots(((x \text{ is } w) \text{ is } \tau_1) \text{ is } \tau_2) \dots \text{ is } \tau_n) \quad (2.35)$$

be interpreted? A clue is furnished by the following example. Suppose that the answer to the question "Is it true that (Françoise is *young*)?" is a numerical truth-value, say 0.5. As

stated earlier, this implies that the grade of membership of Françoise in the class of young women is 0.5, which in turn implies (by (2.29)) that Françoise is 30 years old. Thus, we have

$$(\text{Françoise is } \textit{young}) \text{ is } 0.5 \text{ true} \Rightarrow \text{Françoise is 30 years old.} \quad (2.36)$$

More generally, let  $u$  be a basic variable for an attribute  $B$  and let  $\mu_{\textit{young}}$  denote the membership function which defines the answer  $a \stackrel{\Delta}{=} \textit{young}$  as a fuzzy subset of the universe of discourse,  $U$ , which is associated with the attribute  $B$  (e.g. if  $B \stackrel{\Delta}{=} \textit{age}$ , then  $u$  is a number in the interval  $[0,100]$  and  $U=[0,100]$  is the universe of discourse associated with  $\textit{age}$ ). Now suppose that  $v$  is a numerical truth-value of the answer Françoise is *young*. Then, the age of Françoise is given by

$$B(\text{Françoise}) = \mu_B^{-1}(v) \quad (2.37)$$

where  $\mu_B^{-1}$  is the function inverse to the function  $\mu_B$ .<sup>①</sup> Thus, in the particular case where  $v=0.5$ , (2.29) gives

$$\begin{aligned} B(\text{Françoise}) &= \mu_B^{-1}(0.5) & (2.38) \\ &= 30. \end{aligned}$$

At this juncture, we can employ the extension principle (see the Appendix) to compute the meaning of the answer  $a \stackrel{\Delta}{=} (\text{Françoise is } \textit{young})$  is  $\tau$ , where  $\tau$  is a linguistic truth-value which is characterized by a membership function  $\mu_\tau$ . (E.g. if  $\tau$  is

---

① If the mapping  $\mu_B : U \rightarrow [0,1]$  is not 1-1,  $\mu_B^{-1}$  is the relation (rather than the function) that is inverse to  $\mu_B$ . In any case, the graph of  $\mu_B^{-1}$  is the same as that of  $\mu_B$ , but with the abscissae of  $\mu_B^{-1}$  being the ordinates of  $\mu_B$  and vice versa.

true, then  $\mu_\tau$  is given by (2.14).) Thus, substituting  $\tau$  in (2.37), we obtain

$$\begin{aligned} B(\text{Francoise}) &= \mu_B^{-1}(\tau) \\ &= \mu_B^{-1} \circ \tau \end{aligned} \quad (2.39)$$

which should be interpreted as the composition<sup>①</sup> of the binary relation  $\mu_B^{-1}$  and the unary relation  $\tau$ . In more general terms, this result may be stated as the following proposition.

*Proposition 2.40.* An answer of the form

$$a \stackrel{\Delta}{=} (x \text{ is } w_1) \text{ is } \tau \quad (2.41)$$

where  $x$  is an object in  $X$ ,  $w_1$  is a fuzzy subset of  $U$ , and  $\tau$  is a truth-value (numerical or linguistic), implies the answer

$$a^* \stackrel{\Delta}{=} x \text{ is } w_2 \quad (2.42)$$

where  $w_2$  is related to  $w_1$  and  $\tau$  by

$$w_2 = \mu_{w_1}^{-1} \circ \tau. \quad (2.43)$$

In (2.43),  $\mu_{w_1}^{-1}$  is the relation inverse to  $\mu_{w_1}$ , where  $\mu_{w_1}$  is the membership function of  $w_1$  and the right-hand member of (2.43) represents the composition of  $\mu_{w_1}^{-1}$  with the unary relation (fuzzy set)  $\tau$ . (See Appendix.)

Repeated application of Proposition 2.40 to an answer of the form (2.25) leads to the general result

$$a \stackrel{\Delta}{=} (\dots(((x \text{ is } w_1) \text{ is } \tau_1) \text{ is } \tau_2) \dots \text{ is } \tau_n) \Rightarrow a^* \stackrel{\Delta}{=} x \text{ is } w_{n+1} \quad (2.44)$$

---

① The composition of a binary relation  $R$  in  $U_1 \times U_2$  with a unary relation  $S$  in  $U_2$  is a unary relation  $R \circ S$  in  $U_1$  whose membership function is given by  $\mu_{R \circ S}(u_1) = \bigvee_{u_2} \mu_R(u_1, u_2) \wedge \mu_S(u_2)$ , where  $\bigvee \stackrel{\Delta}{=} \max$  and  $\bigwedge \stackrel{\Delta}{=} \min$ .

where

$$w_{n+1} = \mu_{w_n}^{-1} \circ \tau_n \quad (2.45)$$

$$w_n = \mu_{w_{n-1}}^{-1} \circ \tau_{n-1}$$

.....

$$w_2 = \mu_{w_1}^{-1} \circ \tau_1$$

and  $\mu_{w_i}, i=1, \dots, n$ , is the membership function of  $w_i$ .

As a simple illustration of (2.43), a graphical representation of the composition  $\mu_{w_1}^{-1} \circ \tau_1$ , is shown in Fig. 4. Here  $\mu_{young}$  is the membership function of  $w_1 = young_1$ , with the base variable being the numerical age  $u$ .  $\tau_1$  is assumed to be *very true*, whose membership function is plotted as shown, with  $v$  playing the role of abscissa. The point,  $\alpha$  on  $\mu_{very\ true}$  which has the abscissa  $v$  has the ordinate  $\mu_{very\ true}(v)$ , and, correspondingly, the point,  $\beta$ , on  $\mu_{young_1}^{-1}$  which has the abscissa  $v$  has the ordinate  $\mu_{young_1}^{-1}(v)$ . Now, from  $\alpha$  and  $\beta$  we can construct a point  $\gamma$  on  $\mu_{young_2}$  with abscissa  $\mu_{young_1}^{-1}(v)$  and ordinate  $\mu_{very\ true}(v)$ . In this way, by varying  $v$  from 0 to 1, we can generate the plot of  $\mu_{young_2}$ , which is the membership function of  $w_2$  as defined by (2.43).

An important conclusion which is implicit in (2.44) is that any nested assertion of the form

$$((x \text{ is } w_1) \text{ is } \tau_1) \dots \text{ is } \tau_n \quad (2.46)$$

may be replaced by an equivalent assertion of the form

$$x \text{ is } w_{n+1} \quad (2.47)$$

which does not contain any truth-values. Thus, the use of truth-values in (2.46) serves indirectly the same function as a linguistic modifier  $m$  which transforms  $w_1$  into  $mw_1$ .



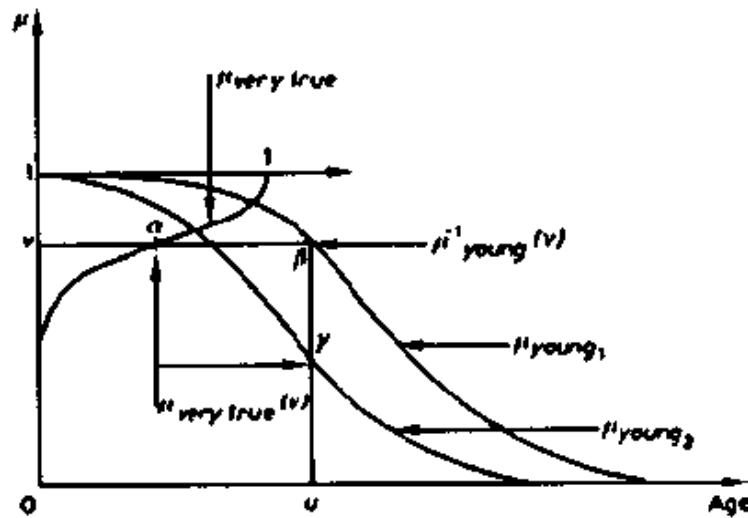

Fig. 4. Composition of  $\mu_{young_1}^{-1}$  with  $\tau \triangleq \text{very true}$ .

## THE RELATION BETWEEN CLASSIFICATIONAL AND ATTRIBUTIONAL QUESTIONS

In the case of a non-fuzzy classificational question, the answer-set,  $A$ , has only two elements which are usually designated as  $\{\text{YES, NO}\}$ ,  $\{\text{TRUE, FALSE}\}$  or  $\{0, 1\}$ . By contrast, the answer-set of an attributinal question is usually a continuum  $U$  or a countable set of linguistic values defined over  $U$ . Thus, in general, an answer to an attributinal question conveys considerably more information than an answer to a nonfuzzy classificational question.

In the case of fuzzy classificational questions, however, the answer-set may be the unit interval  $[0, 1]$  or a countable set of linguistic values defined over  $[0, 1]$ . In such cases, the distinction between classificational and attributinal questions is much less pronounced and, in fact, there may be equivalence between them.

To be more specific, let us assume for concreteness that  $U$  is

the real line and  $F$  is a fuzzy subset of  $U$ .  $F$  will be said to be *amodal* if its membership function  $\mu_F$  is strictly monotone, which implies that the mapping  $\mu_F : U \rightarrow [0, 1]$  is one-one. If  $F$  is not amodal but is convex<sup>①</sup> or concave, then  $F$  will be said to be *modal*. Typically, the membership function of an amodal fuzzy set has the form shown in Fig. 5, whereas that of a modal set has the appearance of a peak or a valley (Fig. 6).

Let  $Q_c \triangleq F?$  be a classificational question which has the same body as an attributional question  $Q_a \triangleq F?$  For example, a specific question  $q_c$  may be worded as "Is Jeanne *young*?" while the wording of  $q_a$  might be "How *young* is Jeanne?" Clearly, if *young* is an amodal fuzzy set, then from an answer to  $q_c$  such as "Jeanne is 0.9 *young*" we can deduce the age of Jeanne and, conversely, from the age of Jeanne, say  $age \triangleq 32$ , we can deduce her grade of membership in the fuzzy set *young*. Thus, when  $F$  is an amodal fuzzy set or, more generally, a fuzzy set whose membership function is a one-one mapping, the answer to a classificational question conveys the same information as the answer to an attributional question.

Now suppose that  $F$  is a modal fuzzy set, e. g.  $F \triangleq$  *middle-aged*, whose membership function has the form shown in Fig. 7. In this case, from the specification of the grade of membership in *middle-aged*, one cannot deduce the value of the attribute *age*

---

① A fuzzy set  $F$  in  $U$  is convex if  $\mu_F$  satisfies the inequality  $\mu_F(\lambda u_1 + (1 - \lambda)u_2) \geq \min(\mu_F(u_1), \mu_F(u_2))$ , for all  $u_1, u_2$  in  $U$  and all  $\lambda$  in  $[0, 1]$ . A fuzzy set  $F$  is *concave* if its complement is convex. Additional details may be found in Zadeh (1966).

uniquely. Thus, if  $F$  is modal, an answer to the classificational question "Is  $x$   $F$ ?" e. g., "Is Freda *middle-aged*?" is less informative than an answer to the attributional question "What is the *age* of Freda?"

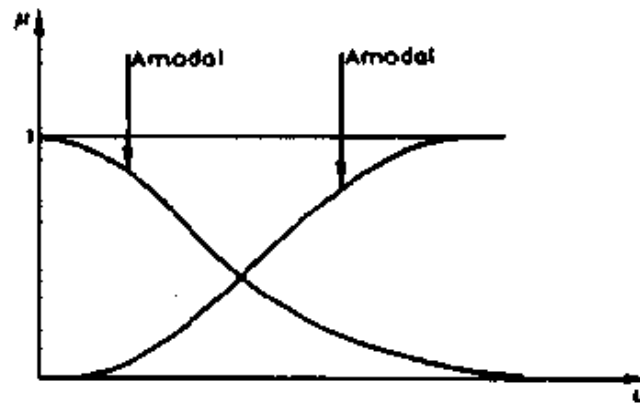

Fig. 5. Amodal fuzzy sets.

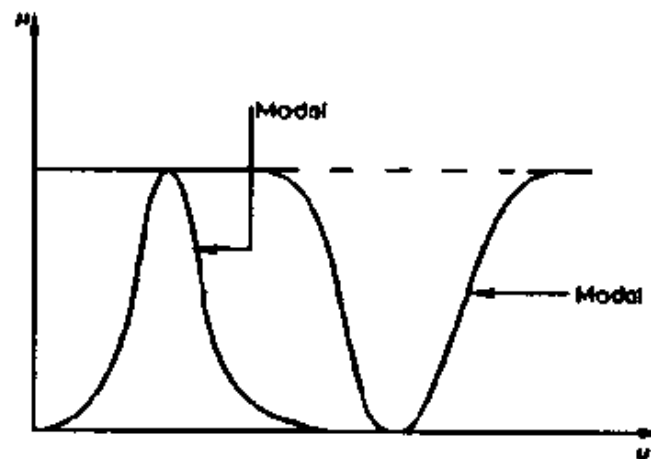

Fig. 6. Compatibility functions of modal fuzzy sets.

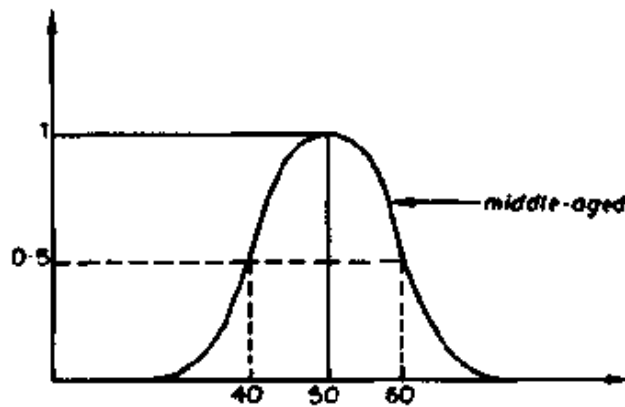

Fig. 7. Representation of *middle-aged* as a modal fuzzy set.

It should be noted that Comment 2.18 implies that a classificational question  $Q \triangleq B?$  may always be regarded as an attributional question whose body is the label of the membership function of  $B$ . Thus, what the above discussion indicates is that although it is not true in general that an attributional question is equivalent to a classificational question with the same body, this is the case when  $B$  is an amodal fuzzy set.

### 3. Composite questions and their representations

The concept of an atomic question which we discussed in the preceding section provides a basis for the definition of the more general concept of a *composite question*. This concept and its representations will be the focus of our attention in the sequel.

Stated informally, an *n-adic composite question*  $Q$ , with body  $B$ , is a question composed of  $n$  constituent questions  $Q_1, \dots, Q_n$  with bodies  $B_1, \dots, B_n$ , respectively, such that the answer to  $Q$  is dependent upon the answers to  $Q_1, \dots, Q_n$ . Thus, a *monadic* question has a single constituent, a *dyadic* question has two

constituents, a *triadic* question has three constituents, etc. A constituent question may be atomic or composite.

An  $n$ -adic composite question or, simply, an  $n$ -adic question,  $Q$ , is characterized by its *relational representation*,  $B(B_1, \dots, B_n)$  (or simply  $B$ , when no confusion with the body,  $B$ , of  $Q$  can arise), whose tableau has the form shown in Table 1. In this tableau,  $r'_j$  and  $r_i$  range over the admissible answers to  $Q_j$  and  $Q$ , respectively, with  $A_j$  and  $A$  representing the answer-sets associated with  $Q_j$  and  $Q$ , and  $a_j$  and  $a$  denoting their generic elements. Thus, if  $Q$  is an  $n$ -adic question, then  $B$  is a non-fuzzy  $(n+1)$ -ary relation from the cartesian product  $A_1 \times \dots \times A_n$  to  $A$ . In particular, if  $Q$  is a monadic question, then  $B$  is a binary relation, and if  $Q$  is atomic then  $B$  is a unary relation.

**Table 1**

*Relational representation of  $Q$ . (Depending on the circumstances, the columns of  $B$  may be labeled  $Q_1, \dots, Q_n, Q$  or  $B_1, \dots, B_n, B$ .)*

$Q_1$	$Q_2$	$Q_j$	$Q_n$	$Q$
$r'_1$	$r'_2$	$r'_j$	$r'_n$	$r_1$
$r''_1$	$r''_2$	$r''_j$	$r''_n$	$r_2$
$r'_i$	$r'_j$	$r'_i$	$r'_n$	$r_i$
$r'_m$	$r'_n$	$r'_m$	$r'_n$	$r_m$

Generally, we shall assume that the entries in  $B$  are linguistic in nature, i. e. are linguistic attribute-values and/or linguistic truth-values and/or linguistic grades of membership. Thus, if  $U_j$  is a universe of discourse associated with  $A_j$ , then an answer  $a'_j \in A_j$  will, in general, be a label of a fuzzy subset of  $U_j$ . The generic elements of  $U_j$  and  $U$  will be denoted by  $u_j$  and  $u$ ,

respectively, and will be referred to as the *base variables* for  $A_i$  and  $A$ . When it is necessary to differentiate between attributional and classificational questions, the universes of discourse for the latter will be denoted by  $V$  instead of  $U$ .

*Example 3.1.* Consider a composite classificational question  $Q \stackrel{\Delta}{=} \text{big?}$  which is composed of two classificational atomic questions  $Q_1 \stackrel{\Delta}{=} \text{wide?}$  and  $Q_2 \stackrel{\Delta}{=} \text{long?}$ , and one attributional atomic question  $Q_3 \stackrel{\Delta}{=} \text{height??}$ . The answer-sets associated with  $Q_1, Q_2, Q_3$  and  $Q$  are assumed to be given by ( $f, b, t, l, m, h$  are abbreviations for *false, borderline, true, low, medium* and *high*, respectively)

$$A_1 = A_2 = A = f + b + t \quad (3.2)$$

$$A_3 = l + m + h \quad (3.3)$$

where  $f, b$  and  $t$  are fuzzy subsets of the unit interval defined by (2.8), (2.9) and (2.10), and  $l, m$  and  $h$  are fuzzy subsets of the real line defined by expressions of the form (2.16), (2.15) and (2.14) with parameters  $\alpha, \beta$ , and  $\gamma$ .

The relational tableau for  $B(B_1, \dots, B_n)$  is assumed to be given by (in partially tabulated form) by Table 2.

**Table 2**

*Relational representation of big(wide, long, height)*

<i>wide?</i>	<i>long?</i>	<i>height?</i>	<i>big?</i>
<i>t</i>	<i>t</i>	<i>h</i>	<i>t</i>
<i>t</i>	<i>t</i>	<i>m</i>	<i>t</i>
<i>t</i>	<i>t</i>	<i>l</i>	<i>b</i>
<i>t</i>	<i>t</i>	<i>l</i>	<i>f</i>
<i>t</i>	<i>b</i>	<i>h</i>	<i>b</i>
<i>t</i>	<i>f</i>	<i>h</i>	<i>b</i>

<i>wide?</i>	<i>long?</i>	<i>height?</i>	<i>big?</i>
<i>t</i>	<i>f</i>	<i>h</i>	<i>f</i>
<i>b</i>	<i>f</i>	<i>l</i>	<i>b</i>
<i>f</i>	<i>f</i>	<i>l</i>	<i>f</i>

There are two important observations to be made concerning  $B(B_1, \dots, B_n)$ . First in general  $B(B_1, \dots, B_n)$  is a relation rather than a function. In Table 2, this manifests itself by the fact that the entries in the column labeled *big?* are not uniquely determined by the entries in the columns *wide?*, *long?* and *height?*. For example, corresponding to  $a^1 = t, a^2 = t$  and  $a^3 = l$ , we have both  $a = b$  and  $a = f$ . This implies that, if the answer to *wide?* is *true*, to *long?* is *true* and to *height?* is *low*, then the answer to *big?* could be either *borderline* or *false*.

Second, the tableau may not be complete, that is, certain combinations of the admissible answers to constituent questions may be missing from the table. For example,  $a^1 = f, a^2 = b$  and  $a^3 = b$  may not be in the table. This may imply that (a) the particular combination of answers cannot occur, or (b) the answer to  $Q$  corresponding to the missing entries is not known—which is equivalent to assuming that the answer is the union of all admissible answers, i. e. is the answer-set  $A$ .

Case (a) implies that there is some interdependence between the constituent questions in the sense that the knowledge of answers to some of the constituent questions restricts the possible answers to others. If the  $Q_i$  are viewed as variables as in (2.18), then (a) implies that the  $Q_i$  are  $\lambda$ -interactive in the sense defined in Zadeh (1975a). Unless stated to the contrary, we shall

assume that the missing rows imply (a) rather than (b). A more detailed discussion of this issue will be presented in section 4.

### ALTERNATIVE REPRESENTATIONS OF B; ALGEBRAIC REPRESENTATION

The relational representation, B, of a composite question Q may in turn be represented in a variety of ways of which the most useful ones are; (a) the *tabular representation*, which we have described already, (b) the *algebraic representation*, which we shall discuss presently, (c) the *analytic representation*, which we shall discuss following (b), and (d) the *branching questionnaire representation*, which will be discussed in section 4.

In the algebraic representation, the *i*th row,  $i=1, 2, \dots, m$  of the tableau of B is expressed as a Q/A *sequence* of the form

$$Q_1 r_1^1 Q_2 r_2^2 \dots Q_n r_n^n // Q r_i \quad (3.4)$$

or, more simply as a Q/A *string*

$$r_1^1 r_2^2 \dots r_n^n // r_i \quad (3.5)$$

where it is understood that  $r_j^j, j=1, \dots, n$  is an admissible answer to the constituent question  $Q_j$ , and  $r_i$  is an admissible answer to the composite question Q. B as a whole, then, may be expressed algebraically as the summation (i. e. the union) of the Q/A strings corresponding to the rows of the tableau of B. Thus, we may write

$$B = r_1^1 r_1^2 \dots r_1^n // r_1 + r_2^1 r_2^2 \dots r_2^n // r_2 + \dots + r_m^1 r_m^2 \dots r_m^n // r_m \quad (3.6)$$

or, more compactly,

$$B = \sum_i r_i^1 r_i^2 \dots r_i^n // r_i \quad (3.7)$$

*Example 3.8.* In the algebraic form, the tableau of the



relational representation defined by Table 2 may be expressed as

$$\begin{aligned}
 B = & tth//t + ttm//t + ttl//b & (3.9) \\
 & + ttl//f + tbh//b + tfh//b \\
 & + tfh//f + bfl//b + \dots + ffl//f.
 \end{aligned}$$

As in the case of regular expressions, an important advantage of representations of the form (3.9) is that the operations of union (+) and string concatenation may be treated in much the same manner as addition and multiplication. Thus, the terms in (3.9) may be combined or expanded in accordance with the replacement rules which are illustrated below by examples.

$$ttf//f + tff//t = t(tf//t + ff//t) \quad (3.10)$$

$$tf//t + ftf//t = (t+f)tf//t \quad (3.11)$$

$$tfb//t + ttb//t = t(f+b)b//t \quad (3.12)$$

$$tfb//t + tfb//b = tfb//(t+b) \quad (3.13)$$

$$\begin{aligned}
 (t+f)(f+b)t//t = & tft//t + fft//t + tbt//t + fbt//t. \\
 & (3.14)
 \end{aligned}$$

For example, using the above identities in (3.9), we can write B in a partially factored form as

$$\begin{aligned}
 B = & tt(h+m)//t + ttl//(b+f) + t(b+f)h//b + \\
 & + (tfh + ffl)//f + \dots + bfl//b.
 \end{aligned} \quad (3.15)$$

It should be noted that the replacement of the left-hand member by the right-hand member involves a factorization in (3.10), (3.11), (3.12) and (3.13), and an expansion in (3.14). In general, factorization has the effect of *raising* the *level* of an expression (in the sense of decreasing the number of operations that have to be performed for its evaluation) while an expansion has the opposite effect. For example, the evaluation of the

arithmetic expression  $xy + xz$  requires three operations, while that of the factored form  $x(y+z)$  requires only two. In this case, the representation of B in the *normal form*<sup>①</sup>(3.9) has the lowest possible level among all algebraic representations involving the admissible answers to the  $Q_j$  and Q.

## THE MEANING OF B

The question of what constitutes the meaning of B may be viewed as a special case of the following problem in semantics.<sup>②</sup> Suppose that we are given a string of terms (words)  $W_1W_2\cdots W_n$  with the meaning of each term defined as a subset of a universe of discourse U. What is the meaning of the composite term  $W_1W_2\cdots W_n$ —that is, what is the subset of U whose label is  $W_1W_2\cdots W_n$ ?

As a special instance of this problem consider two finite non-fuzzy sets G and H whose elements are  $g_1, \dots, g_m$  and  $h_1, \dots, h_n$ , respectively. When we write

$$G = g_1 + \dots + g_m \quad (3.16)$$

$$H = h_1 + \dots + h_n \quad (3.17)$$

the right-hand side of the equation defines the meaning<sup>③</sup> of the label on the left-hand side. Now, if we write the Cartesian

① This usage of the term *normal form* is consistent with that of Codd (1971) in his work on relational models of data. A related concept is that of *characteristic set* in the Vienna definition language (Lucas, 1968; Wegner, 1972).

② A more detailed discussion of this problem may be found in Zadeh (1971b, 1972a).

③ The term *meaning* is used here in the sense of denotational semantics (Carnap, 1956; Hempel, 1952; Church, 1951; Quine, 1953; Frege, 1952; Martin, 1963).

product  $G \times H$  as a string  $GH$ , then the meaning of  $G \times H$  may be obtained very simply by expanding the algebraic product of  $G$  and  $H$ . Thus,

$$G \times H = GH = (g_1 + \dots + g_m)(h_1 + \dots + h_n) = g_1 h_1 + \dots + g_m h_n \quad (3.18)$$

where  $g, h_j$  should be interpreted as the ordered pair  $(g_i, h_j)$ .

Now suppose that  $G$  and  $H$  are finite fuzzy sets defined by

$$G = \mu_1/g_1 + \dots + \mu_m/g_m \quad (3.19)$$

$$H = v_1/h_1 + \dots + v_n/h_n \quad (3.20)$$

where  $\mu_i/g_i$  means that the grade of membership of  $g_i$  in  $G$  is  $\mu_i$ , and likewise for  $H$ . Then, for the Cartesian product of  $G$  and  $H$  we obtain

$$\begin{aligned} G \times H &= (\mu_1/g_1 + \dots + \mu_m/g_m)(v_1/h_1 + \dots + v_n/h_n) \\ &= (\mu_1 \wedge v_1)/g_1 h_1 + \dots + (\mu_m \wedge v_n)/g_m h_n \end{aligned} \quad (3.21)$$

where

$$\mu_i \wedge v_j \triangleq \min(\mu_i, v_j). \quad (3.22)$$

More generally, let  $G_1, \dots, G_n$  be fuzzy subsets of  $U_1, \dots, U_n$  defined by

$$G_j = \sum_{i=1}^{m_j} \mu_i^j / u_i^j. \quad (3.23)$$

Then

$$G_1 \times \dots \times G_n = G_1 \dots G_n = \sum_i (\mu_{i_1}^1 \wedge \dots \wedge \mu_{i_n}^n) / u_{i_1}^1 \dots u_{i_n}^n \quad (3.24)$$

which implies that the right-hand member of (3.24) constitutes the meaning of the string  $G_1 \dots G_n$  (or, equivalently,  $G_1 \times \dots \times G_n$ ).

Returning to the question of what constitutes the meaning of  $B$ , let us focus our attention on the algebraic representation of  $B$  as expressed by (3.6). If the  $r_i^j$  and  $r$ , in (3.6) are assumed to be

fuzzy subsets of  $U_1, \dots, U_n, U$ , then each term in (3.6) is a Cartesian product of fuzzy sets in the sense of (3.24), and  $B$  as a whole is the union of such Cartesian products. Thus, upon the expansion of each term in accordance with (3.24) and summing the results, we obtain the expression for a fuzzy  $(n+1)$ -ary relation from  $U_1 \times \dots \times U_n$  to  $U$  which may be viewed as the *denotational meaning* of  $B$ <sup>①</sup>. This fuzzy relation will be denoted by  $B_\beta$  and will be referred to as the  $\beta$ -representation of  $B$ , with  $\beta$ —standing for *base variable*—serving to signify that  $B_\beta$  is a fuzzy relation from  $U_1 \times \dots \times U_n$  to  $U$  whereas  $B$  is a non-fuzzy relation from  $A_1 \times \dots \times A_n$  to  $A$ .

In summary, the main points of the foregoing discussion may be stated as follows.

*Proposition 3.25.* Let  $B$  be an  $(n+1)$ -ary non-fuzzy relation from  $A_1 \times \dots \times A_n$  to  $A$  which constitutes a relational representation of a composite question  $Q$ . If the answers to  $Q$  and the constituent questions in  $Q$  are fuzzy subsets of their respective universes of discourse  $U, U_1, \dots, U_n$ , then  $B$  induces an  $(n+1)$ -ary fuzzy relation  $B_\beta$  which may be derived from  $B$  by the process of expansion. The fuzzy relation  $B_\beta$  constitutes the *denotational meaning* of  $B$  in the universe of discourse  $U_1 \times \dots \times U_n \times U$ .<sup>②</sup>

---

① In performing the expansion and summation of terms in  $B$ , we are tacitly assuming that the constituent questions  $Q_1, \dots, Q_n$  are  $\beta$ -non-interactive (Zadeh, 1975a) in the sense that the base variables  $u_1, \dots, u_n$  are jointly unconstrained.

② In cases in which the body,  $B$ , of a classification question,  $Q$ , is a fuzzy subset of a universe of discourse which does not possess a numerically-valued base variable (e. g.  $Q$ , *beautiful*), it may be necessary to define  $B_\beta$  by exemplification (Bellman, Kalaba & Zadeh, 1966). In general, exemplificational (or ostensive) definitions are human—rather than machine-oriented.

*Example 3.26.* As a very simple illustration of (3.25), consider a  $B$  whose algebraic representation reads

$$B = tt // f^2 + ff // t \quad (3.27)$$

where  $t (\triangleq \text{true})$ ,  $f (\triangleq \text{false})$ , and  $f^2 (\triangleq \text{very false})$  are fuzzy subsets of the universe of discourse

$$V = 0 + 0.2 + 0.4 + 0.6 + 0.8 + 1 \quad (3.28)$$

and are defined by

$$t = 0.6/0.8 + 1/1 \quad (3.29)$$

$$f = 1/0 + 0.6/0.2 \quad (3.30)$$

and

$$f^2 = 1/0 + 0.36/0.2. \quad (3.31)$$

On substituting (3.29) – (3.31) into  $tt // f^2$  and expanding, we have

$$\begin{aligned} tt // f^2 &= (0.6/0.8 + 1/1)(0.6/0.8 + 1/1) // (1/0 + 0.36/0.2) \\ &= 0.6/(0.8, 0.8, 0) + 0.6/(0.8, 1, 0) \\ &\quad + 0.6/(1, 0.8, 0) + 1/(1, 1, 0) \\ &\quad + 0.36/(0.8, 0.8, 0.2) + 0.36/(0.8, 1, 0.2) \\ &\quad + 0.36/(1, 0.8, 0.2) + 0.36/(1, 1, 0.2). \end{aligned} \quad (3.32)$$

Performing the same operation on the other term in (3.27) and summing the results, we obtain the desired expression for  $B_p$

$$\begin{aligned} B_p &= 0.36/((0.8, 0.8, 0.2) + (0.8, 1, 0.2) + (1, 0.8, 0.2) \\ &\quad + (1, 1, 0.2)) + 0.6/((0, 0, 0.8) + (0, 0.2, 0.8) \\ &\quad + (0.2, 0, 0.8) + (0.2, 0.2, 0.8) + (0, 0.2, 1) \\ &\quad + (0.2, 0.2, 1)) + 1/((0, 0, 1) + (1, 1, 0)) \end{aligned} \quad (3.33)$$

as a ternary fuzzy relation in  $[0,1] \times [0,1] \times [0,1]$ .

## INTERPOLATION OF B

Knowledge of  $B_\beta$  is of importance in that it provides a basis for an *interpolation* of B, that is, an approximate way of deducing answers to Q corresponding to entries in B which are not elements of the answer-sets  $A_1, \dots, A_n$ .

To illustrate, suppose that Q is a dyadic classificational question whose constituent classificational questions  $Q_1$  and  $Q_2$  have the answer-sets

$$A_1 = A_2 = A = t + b + f.$$

Let B be a relational representation of Q and assume that we wish to find the answer to Q when the answers to  $Q_1$  and  $Q_2$  are, respectively,

$$a^1 = \textit{not very true} \quad (3.34)$$

and

$$a^2 = \textit{rather true}. \quad (3.35)$$

Since  $a^1$  and  $a^2$  are not among the entries in the  $Q_1$  and  $Q_2$  columns of the tableau of B, we cannot use B to find the corresponding entry in the Q column. On the other hand, if we have  $B_\beta$  as a fuzzy ternary relation in  $V_1 \times V_2 \times V$  (which is  $[0, 1] \times [0, 1] \times [0, 1]$  in the case under consideration), then by interpolating B we can obtain an approximation to the answer to Q which corresponds to the answers  $a^1 = \textit{not very true}$  and  $a^2 = \textit{rather true}$ .

Specifically, the desired approximation is given by the composition of  $B_\beta$  with the fuzzy sets  $a^1$  and  $a^2$ , treating  $a^1$  and  $a^2$

as unary fuzzy relations in  $[0, 1]$ . Thus, <sup>①</sup>

$$\text{Answer to } Q = B_{\beta} \circ a^1 \circ a^2. \quad (3.36)$$

The significance of (3.36) becomes somewhat clearer if the right-hand member of (3.36) is interpreted as the projection on  $V$  of the intersection of  $B_{\beta}$  with the cylindrical extensions of  $a^1$  and  $a^2$ . <sup>②</sup> Thus, if  $B_{\beta}$  is visualized as a fuzzy surface in  $V_1 \times V_2 \times V$ , then  $a^1$  and  $a^2$  may be likened to fuzzy points on the coordinate axes  $V_1$  and  $V_2$ , and their cylindrical extensions play the role of fuzzy planes passing through these points. The intersection of these planes with the fuzzy surface is a fuzzy point in  $V_1 \times V_2 \times V$  which upon projection on  $V$  becomes a fuzzy subset of  $V$  expressed by the right-hand member of (3.36). A two-dimensional version of this process is shown in Fig. 8.

### ANALYTIC REPRESENTATION OF $B(B_1, \dots, B_n)$

Consider a composite classificational question  $Q = B?$  whose constituents are classificational questions  $Q_1 = B_1?, Q_2 = B_2?, \dots, Q_n = B_n?$  in which the body,  $B_i$ , of  $Q_i, i = 1, \dots, n$ , is a specified fuzzy subset of the universe of discourse  $V_i$ . Furthermore, assume that the relation  $B(B_1, \dots, B_n)$  is a function from  $A_1 \times \dots \times A_n$  to  $A$ . This implies that an answer to  $Q$ —which may be interpreted as a specification of the grade of membership of a given object  $x$  in  $B$ —is a function of the grades of membership of  $x$  in  $Q_1, \dots,$

---

① It is understood that the right-hand member of (3.36) should be approximated to by an admissible answer to  $Q$ .

② The cylindrical extensions of  $a^1$  and  $a^2$  are, respectively, the ternary fuzzy relations  $a^1 \times V \times V$  and  $V \times a^2 \times V$ . The definition of the projection of a fuzzy relation is given in the Appendix and additional details may be found in Zadeh (1966, 1975a).

$Q_n$ . In this sense, the  $B_i$  form a basis for  $Q$ .

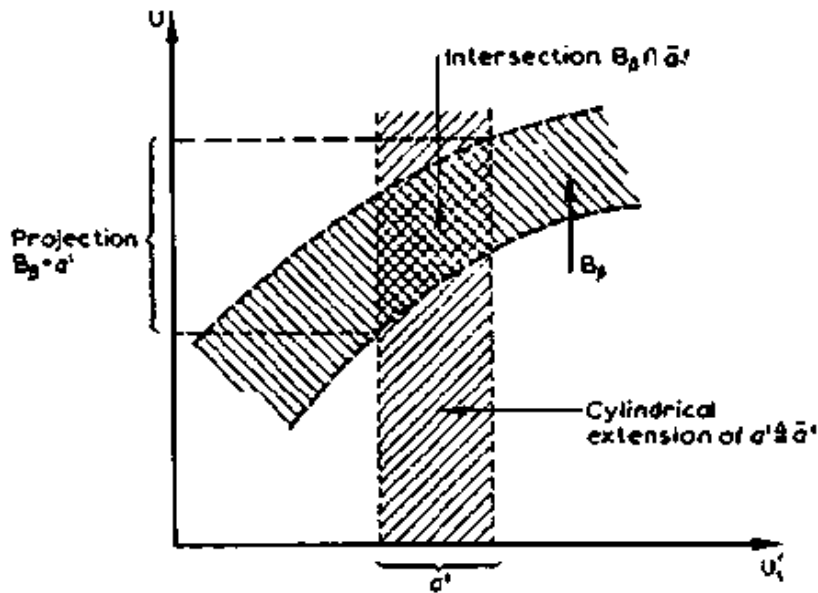

Fig. 8. Graphical interpretation of  $B_2 \circ a_1$ .

When a collection of fuzzy sets  $B_1, \dots, B_n$  forms a basis for  $Q$ , it may be convenient to express  $B$ , the body of  $Q$ , as an explicit function of  $B_1, \dots, B_n$ . Such a function may involve such standard operations as the union,  $B_1 + B_2$ ; intersection,  $B_1 \cap B_2$ ; complement,  $B_1'$ ; product,  $B_1 B_2$ ; Cartesian product,  $B_1 \times B_2$ ; etc. In addition, it may involve other specified operations — in particular, the interactive versions of  $+$  and  $\cap$ , which will be denoted by  $\langle + \rangle$  and  $\langle \cap \rangle$ , respectively. <sup>①</sup> The expression for  $B$  as a function of  $B_1, \dots, B_n$  will be referred to as an *analytic representation* of  $B$ .

*Example 3.37.* Suppose that we wish to define the concept

<sup>①</sup> In general, the angular brackets are used to identify an interactive version of an operation, e. g.,  $\langle \text{and} \rangle$  is an interactive version of *and*. A brief discussion of interactive operations is given in the Appendix.



of HIPPIE. To this end, we form the classificational question  $Q = \text{HIPPIE?}$  and assume that the basis for HIPPIE is the collection of fuzzy sets  $B_1 \triangleq \text{LONG HAIR}$ ,  $B_2 \triangleq \text{BALD}$ ,  $B_3 \triangleq \text{DRUGS}$  and  $B_4 \triangleq \text{EMPLOYED}$ , which will be abbreviated as LH, B, D and EMP, respectively.

An analytic representation for B which constitutes the definition of HIPPIE in terms of  $B_1, B_2, B_3$  and  $B_4$  might be<sup>①</sup>

$$\text{HIPPIE} = (\text{LH} + \text{B}) \cap \text{DRUGS} \cap \text{EMP}' \quad (3.38)$$

or equivalently

$$\text{HIPPIE} = (\text{LH or B}) \text{ and DRUGS and not EMP} \quad (3.39)$$

which implies that the grade of membership of a subject  $x$  in the fuzzy set HIPPIE is related to the grades of membership of  $x$  in the fuzzy set of LONG HAIR subjects, BALD subjects, DRUG TAKING subjects and EMPLOYED subjects by the expression

$$\mu_{\text{H}}(x) = (\mu_{\text{LH}}(x) \vee \mu_{\text{B}}(x)) \wedge \mu_{\text{D}}(x) \wedge (1 - \mu_{\text{EMP}}(x)) \quad (3.40)$$

where  $\vee \triangleq \max$  and  $\wedge \triangleq \min$ . A representation of (3.39) in the form of a flowchart is shown in Fig. 9, with the understanding that YES and NO are answers of the form YES  $\mu$  and NO  $(1 - \mu)$ , where  $\mu$  is the grade of membership of  $x$  in the fuzzy set which labels the question.

*Note 3.41.* If (3.40) does not constitute an acceptable approximation to the expression for  $\mu_{\text{H}}(x)$  as a function of  $\mu_{\text{LH}}(x), \mu_{\text{B}}(x), \mu_{\text{D}}(x)$  and  $\mu_{\text{EMP}}(x)$ , it may be possible to improve on the approximation by employing interactive versions of *and* and /

---

① This definition is used only for illustrative purposes and has no pretense at being a realistic definition of the concept of HIPPIE.

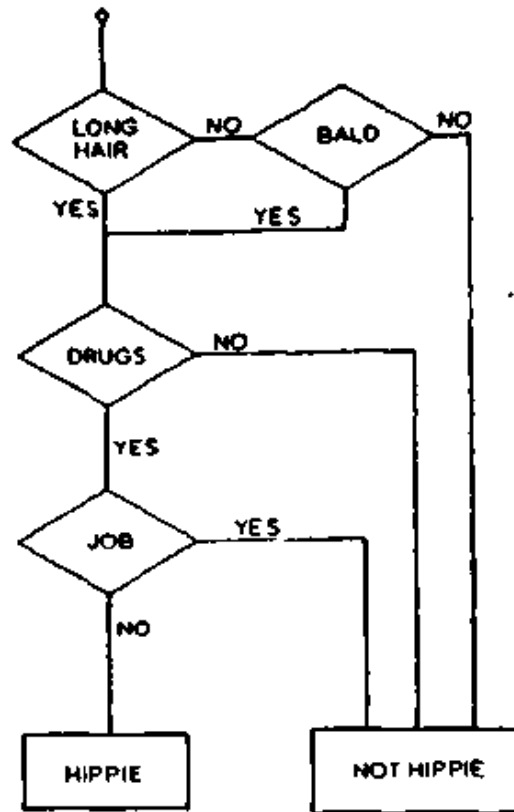

Fig. 9. Flowchart representation of HIPPIE.

or or. For example, we may write

$$\text{HIPPIE} = ((\text{LH or B}) \langle \text{and} \rangle \text{DRUGS}) \text{and not EMP} \quad (3.41)$$

where  $\langle \text{and} \rangle$  is defined by a linguistic relation of the form

$u$	$v$	$u \langle \text{and} \rangle v$
$t$	$t$	$t^2$
$t$	$b$	$b$
$t$	$f$	$f$
$\cdot$	$\cdot$	$\cdot$
$f$	$f$	$f^2$

in which  $t, b, f, t^2$  and  $f^2$  are abbreviations for the linguistic truth-

values *true*, *borderline*, *false*, *very true*, and *very false*.

Basically, the interactive versions of *and* and *or* serve to extend the usefulness of these connectives by providing a means of taking into account the trade-offs that might exist between their operands. However, it should be noted that, in general,  $\langle \textit{and} \rangle$  and  $\langle \textit{or} \rangle$  will not possess such properties as associativity, distributivity, etc., and hence could not be manipulated as conveniently as their non-interactive counterparts.

We turn next to the representation of B by means of branching questionnaires.

#### 4. Branching questionnaires

In one form or another, the concept of a branching questionnaire plays an important role in many fields, especially in taxonomy (Sokal & Sneath 1963; Cole, 1969; Picard, 1965; Oppenheim, 1966), pattern recognition (Watanabe, 1969; Fu, 1968; Selkow, 1974; Budacker & Saaty 1965; Fu, 1974; Slagle & Lee, 1971; Hyafil & Rivest, 1973; Meisel & Michalopoulos, 1973), diagnostics and, more particularly, the identification of sequential machines (Gill, 1962; Tal, 1965; Gill, 1969; Kohavi, Rivierre & Kohavi, 1974). In what follows, the term *branching questionnaire* will be used in a more specific sense to refer to a representation of a composite question,  $Q \stackrel{\Delta}{=} B?$ , in which the constituent questions  $Q_1, \dots, Q_n$  are asked in an order determined by the answers to the previous questions. A branching questionnaire representation of  $Q \stackrel{\Delta}{=} B?$  will be denoted by  $Q^*$  or,

more explicitly, by  $B^*$ .

A branching questionnaire,  $Q^*$ , may be conveniently represented in the form of a tree as shown in Fig. 10 (or, alternatively, in the form of a block diagram, as in Fig. 11). The root of this tree is labeled with the name of the composite question,  $Q$ , or with the name of the body of  $Q$ ; the leaves are labeled with the admissible answers to  $Q$ ; and the internal nodes are labeled with the names of the constituent questions or the names of their bodies. Thus, each fan <sup>①</sup> of the tree represents a constituent question, with each branch of the fan corresponding to an admissible answer to that question. If a branch such as  $a_1^2$  of question  $Q_2$  terminates on  $Q_1$ , it means that if the answer to question  $Q_2$  is  $a_1^2$ , then the next question to be asked is  $Q_1$ . This implies that if the answer to  $Q_2$  is  $a_1^2$ , the answer to  $Q_1$  is  $a_3^1$  and the answer to  $Q_3$  is  $a_1^3$ , then the answer to  $Q$  is  $a_2$ .

Each path from the root of the tree to a leaf represents a particular Q/A sequence, e. g.

$$Q_2 a_1^2 Q_1 a_3^1 Q_3 a_1^3 // Q a_2 \quad (4.1)$$

which may be written more simply as

$$a_1^2 a_3^1 a_1^3 // a_2 \quad (4.2)$$

if the names of the answers to the constituent questions are labeled in a way that makes it possible to associate each answer in the sequence with a unique constituent question.

It is important to note that the only condition on the structure of a branching questionnaire is that on any path from

---

<sup>①</sup> By the *fan* of a tree we mean a node of a tree together with the branches connected to it.

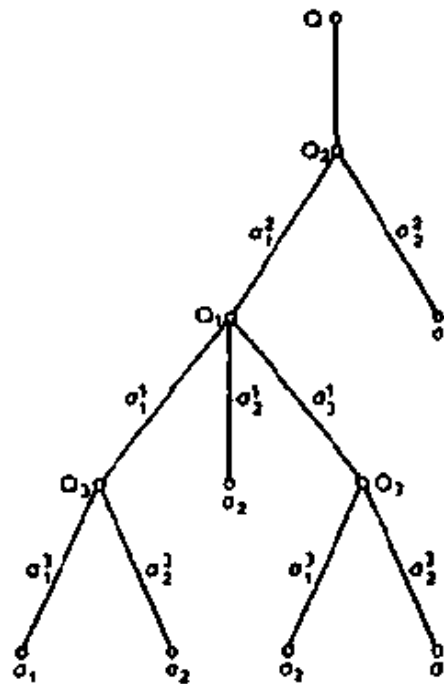

Fig. 10. An example of a branching questionnaire.

the root to a leaf each constituent question is encountered at most once. A prescription of the order in which the constituent questions are to be asked (without regard to the answers to  $Q$ ) is characterized in the manner shown in Fig. 12.

The summation (union) of all  $Q/A$  sequences of the form (4.2) constitutes an algebraic representation of  $Q^*$ . For example, for the branching questionnaire of Fig. 10, we have the representation (using  $Q^*$  in place of  $B$ )

$$\begin{aligned}
 Q^* = & a_1^2 a_1^1 a_1^3 // a_1 + a_1^2 a_1^1 a_2^3 // a_2 + a_1^2 a_2^1 // a_2 \\
 & + a_1^2 a_3^1 a_1^3 // a_2 + a_1^2 a_3^1 a_2^3 // a_1 + a_2^2 // a_1.
 \end{aligned} \tag{4.3}$$

A  $Q/A$  sequence which terminates on an internal node of the tree defines an access path to that node and thereby uniquely identifies it. For example, the  $Q/A$  sequence  $a_1^2$  identifies the node  $Q_1$  in the tree of Fig. 10. Similarly, the leftmost  $Q_3$  in Fig. 10 is

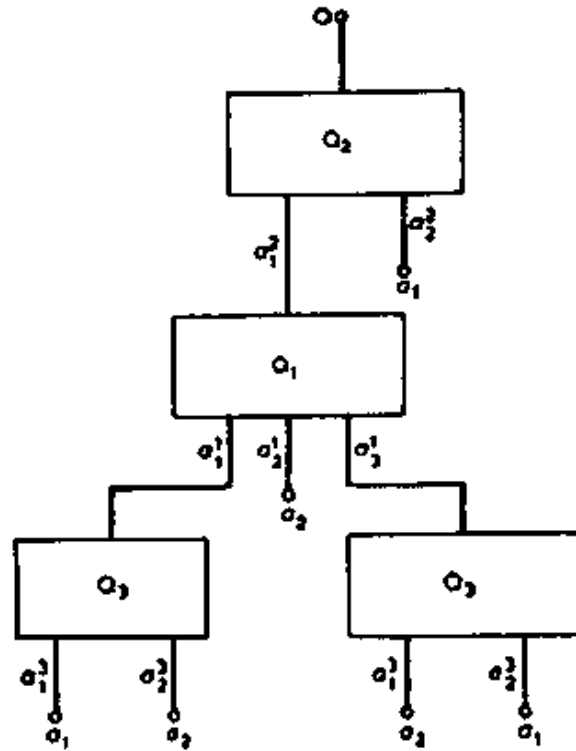

Fig. 11. Block diagram representation of a branching questionnaire.

identified by the Q/A sequence  $a_1^2 a_1^1$ .<sup>①</sup>

Each internal node of the tree may be viewed as the root of a subtree which corresponds to a subquestionnaire of  $Q^*$ . Thus, on factoring  $a_1^2$  in (4.3), we obtain

$$Q^* = a_1^2 (a_1^1 a_1^3 // a_1 + a_1^1 a_2^3 // a_2 + a_2^1 // a_2 + a_3^1 a_1^3 // a_2 + a_3^1 a_2^3 // a_1) + a_2^2 // a_1 \quad (4.4)$$

in which the expressions within the parentheses may be regarded as an algebraic representation of a subquestionnaire which has  $Q_1$  and  $Q_3$  as its constituents.

<sup>①</sup> It should be noted that such Q/A sequences serve a role similar to that of *composite selectors* in the case of a Vienna definition language object (Wegner, 1972).

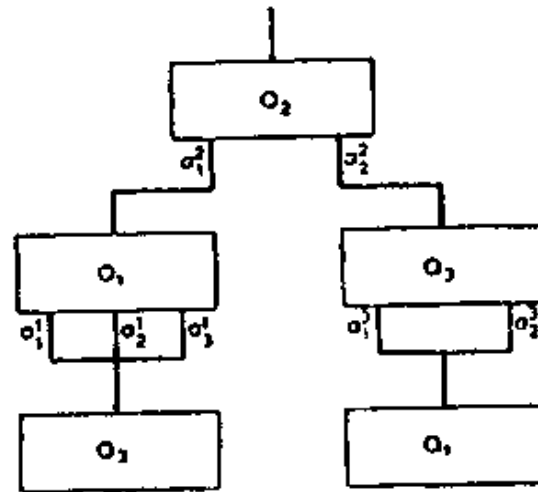

Fig. 12. Specification of the order of questioning.

*Comment 4.5.* By analogy with the concept of a derivative in the case of regular expressions (Tal, 1965; Gill, 1969; Kohavi, Rivierre & Hohavi, 1974; Booth, 1968; Klir & Seidl, 1966; Kohavi, 1970), the coefficients of  $a_1^2$  and  $a_2^2$  in (4.4) may be defined to be the *derivatives* of  $Q^*$  with respect to  $a_1^2$  and  $a_2^2$ , respectively. Thus, on denoting these derivatives by  $D_{a_1^2} Q^*$  and  $D_{a_2^2} Q^*$ , the expression for  $Q^*$  may be rewritten as

$$Q^* = a_1^2 D_{a_1^2} Q^* + a_2^2 D_{a_2^2} Q^*. \quad (4.6)$$

More generally, let  $w$  denote a  $Q/A$  sequence (e. g.,  $w \triangleq a_2^2 a_1^1$ ), and let  $S_w$  denote the subtree of  $Q^*$  which is uniquely determined by  $w$ . Then, we may write

$$D_w Q^* = S_w. \quad (4.7)$$

Now let  $N_1, \dots, N_r$  be the nodes in a cut<sup>①</sup> of  $Q^*$  and let  $Q/A_1,$

① The *cut* of a tree is a set of nodes with the following properties: (a) no two nodes in the cut are on the same path from the root to a leaf; and (b) no other node of the tree can be added to the cut without violating (a) (Budacker & Saaty, 1965; Aho & Ullman, 1973).

$\dots, Q/A_r$  denote the Q/A sequences which lead from the root of  $Q^*$  to  $N_1 \dots N_r$ , respectively. Then in consequence of (4.7), we can assert the identity

$$Q^* = \sum_{i=1}^r Q/A_i D_{Q/A_i} Q^* \quad (4.8)$$

of which (4.6) may be viewed as a special case.

*Note 4.9.* It should be observed that the constituent questions in  $Q^*$  may be  $\lambda$ -interactive in the sense defined in Zadeh (1973), that is, the answers to, say,  $Q_{i_1}, \dots, Q_{i_k}$ , where  $(i_1, \dots, i_k)$  is a subsequence of the index sequence  $(1, 2, \dots, n)$ , may restrict the possible answers to  $Q_{j_1}, \dots, Q_{j_l}$ , where  $(j_1, \dots, j_l)$  is a subsequence complementary to  $(i_1, \dots, i_k)$  (e. g. for  $n=5$ ,  $(i_1, i_2, i_3) \triangleq (2, 4, 5)$  and  $(j_1, j_2) \triangleq (1, 3)$ ). For example, if the answer to an attributional question  $Q_1 \triangleq \text{mother of Julie?}$  is *Frances*, then the answer to  $Q_2 \triangleq \text{sister of Julie?}$  cannot be *Frances* if there is just one *Frances* in the universes  $U_1$  and  $U_2$ . Thus, the answer  $a^2 = \text{Frances}$  is *conditionally impossible given*  $a^1 = \text{Frances}$ .

In the tree representation of a branching questionnaire, the conditional impossibility of an answer to a single question is indicated by associating  $\theta$  (empty set) with the leaf of the corresponding branch (Fig. 13). Thus, in the example under consideration,  $a_2$  is conditionally impossible given  $a_1^2$ . Note that any conditionally impossible answer must of necessity be a leaf of the tree since a Q/A sequence is aborted when a conditionally impossible answer is encountered.

The set of all possible answers to  $Q_1, \dots, Q_n$  constitutes a



restriction on  $Q_1, \dots, Q_n$ . Correspondingly, the conditionally possible answers to  $Q_{j_1}, \dots, Q_{j_k}$  given the answers to  $Q_{i_1}, \dots, Q_{i_s}$  constitute a *conditioned restriction* on  $Q_{j_1}, \dots, Q_{j_k}$  given  $Q_{i_1}, \dots, Q_{i_s}$ .<sup>①</sup> In terms of restrictions, the constituent questions  $Q_1, \dots, Q_n$  are  $\lambda$ -noninteractive if the restriction on  $Q_1, \dots, Q_n$  is the Cartesian product of the answer-sets  $A_1, \dots, A_n$ . Stated more simply, the non-interaction of  $Q_1, \dots, Q_n$  means that the answers to any subset of constituent questions, say  $Q_{i_1}, \dots, Q_{i_s}$ , do not affect the possible answers to the complementary questions  $Q_{j_1}, \dots, Q_{j_k}$ . In what follows, we shall assume, unless stated to the contrary, that the constituent questions in  $Q$  are  $\lambda$ -noninteractive.

### CONDITIONAL REDUNDANCE

In comparing the algebraic representations of  $B$  and  $Q^*$ , (3.6) and (4.3), we observe that every term in  $B$  involves the answers to all of the constituent questions in  $Q$ , whereas a term in  $Q^*$  involves, in general, a subset of the answers to  $Q_1, \dots, Q_n$ .

More specifically, a term such as  $a_2^2 // a_1$  in  $Q^*$  implies that if the answer to  $Q_2$  is  $a_2^2$ , then regardless of the answers to  $Q_1$  and  $Q_3$ , the answer to  $Q$  is  $a_1$ . Thus, in this instance we may say that  $Q_1$  and  $Q_3$  are *conditionally redundant given*  $a_2^2$ . Similarly,  $Q_3$  is conditionally redundant given  $a_1^1 // a_2^1$ . By implication, then, a constituent question  $Q_i$  is *unconditionally redundant* if the answers to  $Q$  are independent of the answers to  $Q_i$ .

---

① A more detailed discussion of conditioned restrictions may be found in Zadeh (1975a).

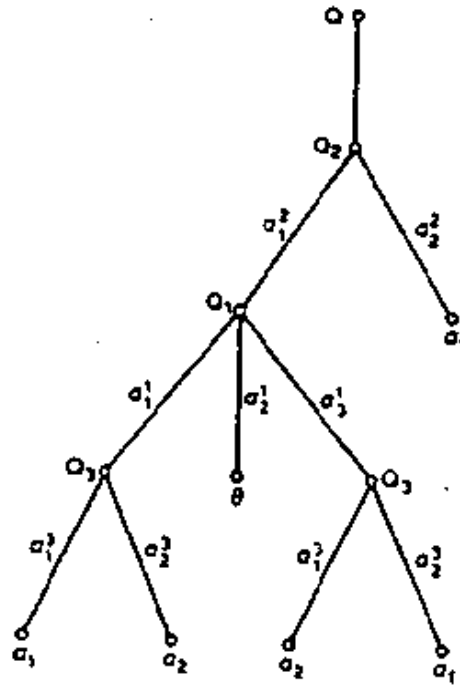

Fig. 13. Illustration of conditional impossibility.

A constituent question  $Q_i$  will be said to be *conditionally redundant given*  $Q_{i_1}, \dots, Q_{i_k}$  if for every set of possible answers  $a_{i_1}^j, \dots, a_{i_k}^j$ ,  $Q_i$  is conditionally redundant given  $a_{i_1}^j, \dots, a_{i_k}^j$ . As we shall see in section 5, the detection of conditional redundancies plays an important role in the construction of efficient branching questionnaires.

*Comment 4. 10.* It should be noted that if the answer to  $Q_i$  is uniquely determined by the answers to  $Q_{i_1}, \dots, Q_{i_k}$ , then  $Q_i$  is conditionally redundant given  $Q_{i_1}, \dots, Q_{i_k}$ . However, in general, conditional redundancy of  $Q_i$  given  $Q_{i_1}, \dots, Q_{i_k}$  is weaker than the dependence of  $Q_i$  on  $Q_{i_1}, \dots, Q_{i_k}$ .

## TABULAR REPRESENTATION OF A BRANCHING QUESTIONNAIRE

As was pointed out already, a term such as  $a_2^2 // a_1$  in (4.3) signifies that if the answer to  $Q_2$  is  $a_2^2$ , then the answer to  $Q$  is  $a_1$ , no matter what the answers to  $Q_1$  and  $Q_3$  might be. Now, "no matter what" or, equivalently, "don't care" may be interpreted as the answers  $a^1 \triangleq a_1^1 + a_2^1 + a_3^1$  to  $Q_1$  and  $a^3 \triangleq a_1^3 + a_2^3$  to  $Q_3$ . Thus, more generally, a "don't care" answer to  $Q_i$  may be interpreted as the answer  $a^i \triangleq A_i \triangleq$  answer-set of  $Q_i$ .

For simplicity, it is convenient to represent an answer of the form  $a^i \triangleq A_i$  by  $\star$  or, if necessary, by  $\star^i$ . With this notation, the tableau of  $Q^\star$  (see 4.3) assumes the form shown in Table 3. (The dotted line(s) in this tableau serves to identify the groups of rows which have the same entry in the  $Q$  column.)

**Table 3**

*Tableau of  $Q^\star$*

$Q_1$	$Q_2$	$Q_3$	$Q$
$a_1^1$	$a_1^2$	$a_1^3$	$a_1$
$a_3^1$	$\star$	$a_2^3$	$a_1$
$\star$	$a_2^2$	$\star$	$a_1$
.....			
$a_3^1$	$a_1^2$	$a_1^3$	$a_2$
$a_1^1$	$a_1^2$	$a_2^3$	$a_2$
$a_2^1$	$a_1^2$	$\star$	$a_2$

A row such as  $\star a_2^2$  in this tableau may be represented

algebraically as<sup>①</sup>

$$\begin{aligned}
 *a_2^2 &= (a_1^1 + a_2^1 + a_3^1) a_2^2 (a_1^3 + a_2^3) \\
 &= a_1^1 a_2^2 a_1^3 + a_1^1 a_2^2 a_2^3 + a_2^1 a_2^2 a_1^3 \\
 &\quad + a_2^1 a_2^2 a_2^3 + a_3^1 a_2^2 a_1^3 + a_3^1 a_2^2 a_2^3.
 \end{aligned} \tag{4.11}$$

On performing similar expansions for all rows in Table 3 which contain stars, we obtain the complete tableau of  $Q^*$ , as shown in Table 4.

The preceding discussion indicates that the tableau of Table 3 may be derived from that of Table 4 by a factorization of terms in the algebraic representation of  $Q^*$ , (4.3), and replacing by  $*$ 's those factors which have the form of the sum of all admissible answers to a constituent question. A systematic procedure for carrying out such factorizations will be described in the following section.

**Table 4**  
*Complete tableau of  $Q^*$*

Q	Q	Q	Q
$a_1^1$	$a_1^2$	$a_1^3$	$a_1$
$a_3^1$	$a_1^2$	$a_2^3$	$a_1$
$a_3^1$	$a_2^2$	$a_2^3$	$a_1$
$a_1^1$	$a_2^2$	$a_3^3$	$a_1$
$a_1^1$	$a_2^2$	$a_2^3$	$a_1$
$a_2^1$	$a_2^2$	$a_2^3$	$a_1$
$a_2^1$	$a_2^2$	$a_2^3$	$a_1$
$a_3^1$	$a_2^2$	$a_2^3$	$a_1$
$a_3^1$	$a_1^2$	$a_1^3$	$a_2$

① In the terminology of switching theory, the terms on the right-hand side of (4.11) are covered by  $*a_2^2$  and  $*a_2^2$  constitutes a prime implicant of  $Q^*$  (Kohavi, 1970; McCluskey, 1965; Marcovitz & Pugsley, 1971).

Q	Q	Q	Q
$a_1^1$	$a_1^2$	$a_2^3$	$a_2$
$a_2^1$	$a_1^2$	$a_1^3$	$a_2$
$a_2^1$	$a_1^2$	$a_2^3$	$a_2$

*Note 4.12.* If the constituent questions in  $Q$  are  $\lambda$ -interactive, then in a term such as  $a_3^1 * a_2^3$ , the star would represent the conditioned restriction on  $Q_2$  given  $a_3^1 a_2^3$ . More generally, in a term of the form  $a_{j_1}^{i_1} \cdots a_{j_t}^{i_t} * j_1 \cdots * j_t$ , the sequence  $* j_1 \cdots * j_t$  would represent the conditioned restriction on  $Q_{j_1}, \dots, Q_{j_t}$  given the Q/A sequence  $a_{j_1}^{i_1} \cdots a_{j_t}^{i_t}$ .

### 5. Construction of branching questionnaires

In constructing a fuzzy-algorithmic definition of a concept  $B$ , the first step would normally involve a tabulation of the relational representation,  $B(Q_1, \dots, Q_n)$ , of a composite question,  $Q = B?$ , which has  $B$  as its body. The second step, then, would involve the construction of a branching questionnaire realization of  $Q$  which is efficient in the sense of minimizing a cost function whose components are the costs of answering the constituent questions in  $Q$ . In practice, such a cost function would usually be prescribed in a highly approximate fashion.

As an illustration of the first step, suppose that we wish to construct a fuzzy-algorithmic definition of the concept of recession. Using our intuitive knowledge of the factors which enter into this concept and the interrelations between them, we construct in an approximate fashion a linguistic relational representation for RECESSION which might have the form

shown in Table 5. <sup>①</sup> In this table, the observation interval is assumed to be a two-quarter period; GNP ↓ denotes the decline in the gross national product; UNEMP denotes unemployment; BANKR ↑ represents the increase in bankruptcies; and DJ ↓ denotes the decline in the Dow Jones stock average in relation to its maximum value over the observation interval.

**Table 5**

*Tableau of relational representation of RECESSION*

GNP ↓	UNEMP	BANKR ↑	DJ ↓	RECESSION
<i>small</i>	<i>low</i>	<i>small</i>	<i>small</i>	<i>false</i>
<i>moderate</i>	<i>low</i>	<i>small</i>	<i>small</i>	<i>not true</i>
<i>high</i>	<i>low</i>	<i>small</i>	<i>small</i>	<i>borderline</i>
<i>high</i>	<i>moderate</i>	<i>moderate</i>	<i>large</i>	<i>rather true</i>
<i>high</i>	<i>high</i>	<i>large</i>	<i>large</i>	<i>very true</i>

It should be noted that the composite question  $Q \triangleq \text{RECESSION?}$  is treated as a classificational question in Table 5, although all of the constituent questions in RECESSION are attributional in nature. Normally, the meaning of the linguistic values of the attributes would be defined in terms of their compatibility functions, which can be computed from the knowledge of the compatibility functions of the primary fuzzy sets. For example, in the case of unemployment, the compatibility functions of the primary fuzzy sets labeled *low* and *high* might be of the form shown in Fig. 14. From these, one can compute, if

<sup>①</sup> This representation is used merely for illustrative purposes and should not be taken as a realistic definition of the concept of a recession. A brief but informative discussion of recessions may be found in Silk (1974) and Clark (1974).

needed, the compatibility functions of *very low*, *more or less high*, etc., by the use of (2.22) and (2.23).

There are several basic problems which are ancillary to the transformation of a relational representation of the definiendum (i. e. the concept under definition) into an efficient branching questionnaire. Of these, one is that of determining the conditional redundancies and/or restrictions which may be present in the relational representation. Another is that of determining the order in which the constituent questions must be asked in order to minimize the average cost of finding the answer to Q.

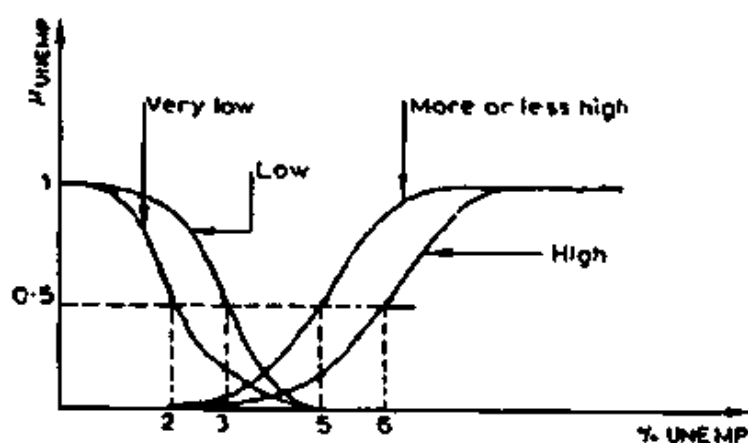

Fig. 14. Compatibility functions of *low*, *very low*, *high* and *more or less high* (not to scale).

These and related problems have many features in common with the minimization of switching circuits (McCluskey, 1965; Marcovitz & Pugsley, 1971; Kandel, 1963), optimal encoding (Jelinek, 1968), feature selection in pattern recognition (Chen, 1971; Mucciardi & Gose, 1971; Tou & Heydorn, 1967; Jardine & Sibson, 1971), and the optimization of decision tables (Pollack, Hicks & Harrison, 1971; Montalbano, 1962; Reinwald & Soland,

1967; Bell, 1974). However, the construction of an efficient branching questionnaire for the purpose of defining a concept presents some special problems relating to the fact that the efficiency of a branching questionnaire is influenced not only by the conditional redundancies but also by the cost of the constituent questions as well as by the conditional probabilities of the admissible answers—probabilities which are conditioned on the answers to the preceding questions in the questionnaire.

In what follows, our discussion of the construction of efficient branching questionnaires will be quite restricted in scope. Thus, we shall focus our attention mainly on the determination of the conditional redundancies in a relational representation and an illustration of the computation of the average cost of finding an answer to  $Q$  for a given branching questionnaire realization of  $B$ .

### COMPACTIFICATION OF $Q$

By the *compactification* of  $Q$  (or  $B$ ) we mean the process of putting the representation of  $Q$  (tabular, algebraic or graphical) into a form that places in evidence the conditional redundancies and/or restrictions in the relational representation of  $Q$ , and thereby achieves a greater degree of compactness in its mode of representation. Thus, the transition from the tableau of Table 4 to that of Table 3 is an instance of compactification of a tabular representation of a composite question.

If the initial representation has the form of a graph or, more specifically, a tree, then the following rule—which is both general and simple to apply—may be employed to compactify the



representation.

*Rule 5.1 (merger rule).* Let  $Q^*$  be a tree representation of a branching questionnaire, and let  $S_1, S_2, \dots, S_t$  be subtrees of  $Q^*$  which are identical (i. e. have the same structure as well as branch and node labels)

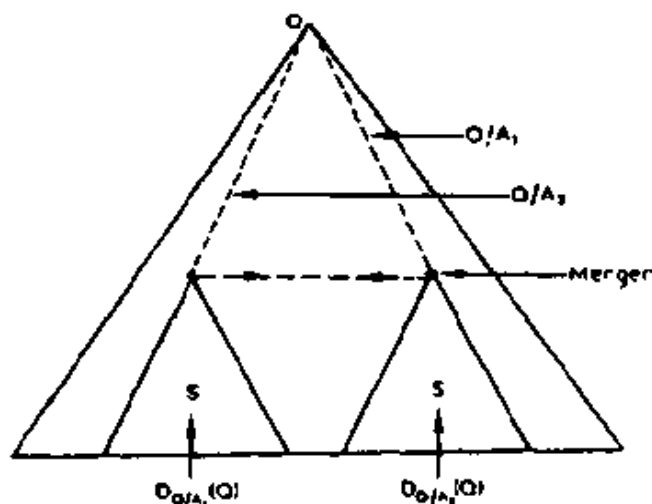

Fig. 15. Illustration of the merger rule.

$$S_1 \equiv S_2 \equiv \dots \equiv S_t \equiv S. \quad (5.2)$$

Then  $S_1, \dots, S_t$  may be merged into a single subtree  $S$ , as shown in Figs 15 and 16.

*Comment 5.3.* It should be noted that the structure resulting from a merger is not a tree but an acyclic graph (with the branches oriented downward) which, for convenience, may be referred to as a *semitree*. More generally, then, in the statement of Rule 5.1 the term *tree* should be replaced throughout by *semitree*.

The basis for the merger rule is provided by the following observation. Let  $Q/A_1, \dots, Q/A_t$  be the  $Q/A$  sequences which terminate on the roots of  $S_1, \dots, S_t$  and let  $Q^*$  be an algebraic

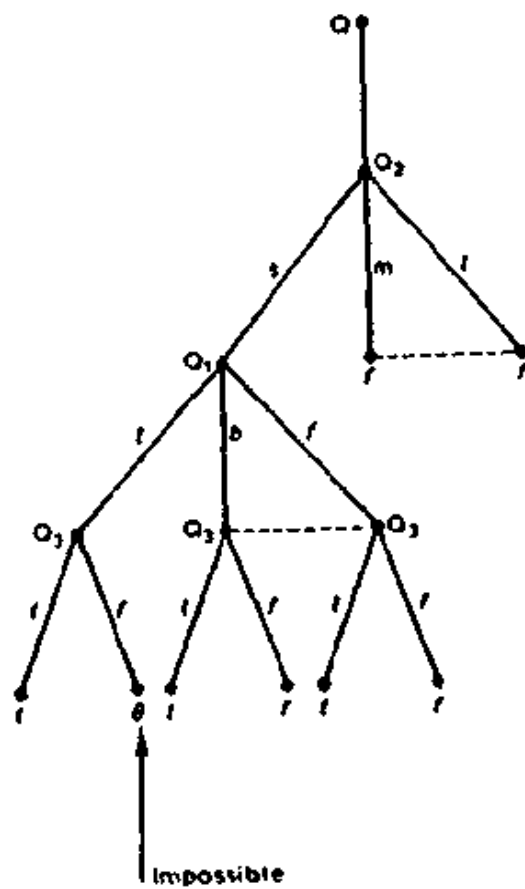

Fig. 16. Illustration of the merger rule—the nodes connected by dashed lines are mergeable.

representation of  $Q$  (see (4.3)). Then by (4.7)

$$S_1 = D_{Q/A_1} Q^* \tag{5.4}$$

.....

$$S_l = D_{Q/A_l} Q^* \tag{5.5}$$

where  $D_{Q/A_\lambda}$  denotes the derivative of  $Q^*$  with respect to  $Q/A_\lambda$ ,  $\lambda = 1, \dots, l$ .

Now let  $N_1, \dots, N_r, r \geq l$ , be a set of nodes in  $Q^*$  which form a cut, with the roots of  $S_1, \dots, S_l$  identified with  $N_1, \dots, N_l$ , respectively. Then by (4.8), we can express  $Q^*$  as

$$Q^* = Q/A_1 D_{Q/A_1} Q^* + \dots + Q/A_l D_{Q/A_l} Q^* + \dots + Q/A_r D_{Q/A_r} Q^*. \quad (5.6)$$

From (5.6) and the assumption that  $S_1 \equiv \dots \equiv S_l \equiv S$ , it follows that the common factor  $D_{Q/A_l} Q^*$  may be factored from the first  $l$  terms in (5.6), yielding the simpler expression

$$Q^* = (Q/A_1 + \dots + Q/A_l) D_{Q/A_l} Q^* + \dots + Q/A_r D_{Q/A_r} Q^*. \quad (5.7)$$

The conclusion that follows from (5.7), then, is that the result of application of Rule 5.1 is a semitree whose algebraic representation is expressed by (5.7).

The conditionally redundant questions in  $Q^*$  may readily be deduced by a straight-forward application of the merger rule, as illustrated in Fig. 17. Thus, assume that the roots of  $S_1, \dots, S_l$ , where  $S_1 \equiv \dots \equiv S_l \equiv S$ , are the leaves of a fan which represents a constituent question, say  $Q_3$ . Then from (5.7) it follows at once that  $Q_3$  is conditionally redundant given  $Q/A_3$ . More generally, if some of the answers to a constituent question are conditionally impossible (e. g. as in  $Q_2$  in Fig. 17), then the condition  $S_1 \equiv \dots \equiv S_l$  need hold only for the conditionally possible answers to  $Q^2$ . Thus, in Fig. 17,  $Q_2$  is conditionally redundant given  $Q/A_2$ .

It is helpful to summarize the foregoing discussion in the form of a proposition.

*Proposition 5.8.* Let  $Q_i$  be a constituent question in  $Q^*$  whose conditionally possible leaves (i. e. the leaves corresponding to conditionally possible answers) are  $N_{i_1}, \dots, N_{i_k}$ , and let  $Q/A_i$  denote the  $Q/A$  sequence terminating on  $Q_i$ . Then  $Q_i$  is conditionally redundant given  $Q/A_i$  if the subtrees (or, more

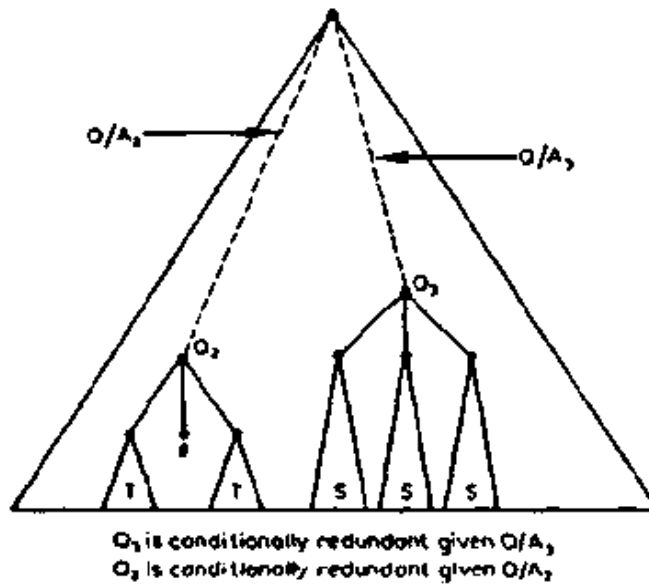

Fig. 17. Application of the merger rule to the identification of conditionally redundant questions.

precisely, the semitrees) with roots at  $N_1, \dots, N_k$  are identical.

### COMPACTIFICATION OF A TABULAR REPRESENTATION

Like most graphical procedures, the merger rule discussed above serves to provide a visual and hence more readily comprehensible idea of how it works. For computational purposes, however, it is preferable to employ compactification techniques which operate on tables rather than graphs.

A technique of this type which is described below<sup>①</sup> is a straightforward adaptation of the well-known Quine-McCluskey algorithm (McCluskey, 1965; Marcovitz & Pugsley, 1971; Kandel, 1973) for the minimization of switching functions. More

① For simplicity, we shall assume that the constituent questions are non-interactive in the sense of Zadeh (1975a).

specifically, suppose that we wish to compactify a given tableau  $Q(Q_1, \dots, Q_n)$ , e. g. that of Table 4, in which the rows which have the same entry in the  $Q$  column are grouped together as shown. The steps described below, then, would be applied to each such group. (For easier comprehension, the algorithm is expressed in informal terms.)

*Algorithm 5.9.* The following steps are performed successively for each column in  $Q$ , starting with  $j=1$ .  $r_i^j$  denotes an admissible answer in the  $i$ th row of the  $j$ th column.

1. Starting with  $i=1$ , check if  $r_i^j$  can be replaced by  $*$  (i. e. by the answer-set  $A_1$ ). (The answer is YES if there are rows in  $Q$  which upon addition (treating the rows as strings, as in (3.6), and factoring the common factor  $r_1^j \dots r_1^j$  yield the term  $A_1 r_1^j \dots r_1^j$ .) If the answer is YES, add the row  $* r_1^j \dots r_1^j$  to the tableau, yielding what will be referred to as an *augmented* tableau.

As an illustration, in the tableau of Table 6, the answer is NO for  $r_1^1$  and YES for  $r_2^1$ . Consequently,  $* a_2^1 a_1^1$  is added to the tableau as shown in Table 6.

2. Step 1 is applied in succession to all of the entries in column 1 of  $Q$  which fall into the group under consideration.

This concludes Pass (1) of the algorithm, yielding an augmented tableau which consists of the original rows together with rows in which the entry in column 1 is a star.

3. Steps 1 and 2 are applied successively to the entries in Columns 2, 3, ...,  $n$ , with the understanding that the initial tableau for Pass ( $i+1$ ) is the augmented tableau obtained

at the conclusion of Pass ( $i$ ), with \* treated as if it were an element of an answer-set. Furthermore, in applying Step 1 to an entry in column  $j$ , all of the rows augmented up to that point must be considered.

4. In the final augmented tableau obtained at the conclusion of Pass ( $n$ ), each of the rows is checked to see if it is contained as a term in an expansion of a starred term in the final augmented tableau. If the answer is NO, the row in question is transferred to a tableau labeled  $Q^*$ , with the corresponding answer to  $Q$  being the same as for the group under consideration.

**Table 6**

*Intermediate results of Algorithm 5.9 for group 1 of rows of Q*

	$Q_1$	$Q_2$	$Q_3$	$Q$
Group 1 (initial)	$a_1^1$	$a_1^2$	$a_1^3$	$a_1$
	$a_1^1$	$a_2^2$	$a_1^3$	$a_1$
	$a_2^1$	$a_2^2$	$a_1^3$	$a_1$
	$a_3^1$	$a_3^2$	$a_1^3$	$a_1$
	$a_3^1$	$a_1^2$	$a_2^3$	$a_1$
	$a_1^1$	$a_2^2$	$a_2^3$	$a_1$
	$a_2^1$	$a_2^2$	$a_2^3$	$a_1$
	$a_3^1$	$a_2^2$	$a_2^3$	$a_1$
Pass(1)	*	$a_2^2$	$a_1^3$	$a_1$
	*	$a_2^2$	$a_2^3$	$a_1$
Pass(2)	$a_3^1$	*	$a_2^3$	$a_1$
Pass(3)	$a_1^1$	$a_2^2$	*	$a_1$
	$a_2^1$	$a_2^2$	*	$a_1$
	$a_3^1$	$a_2^2$	*	$a_1$
	*	$a_2^2$	*	$a_1$

As an illustration, in Table 6  $a_1^1 a_2^2 a_1^3$  is contained as a term in

the expansion of  $a_2^2 a_1^3$  and hence is not transferred to  $Q^{**}$ . The row  $a_1^1 a_1^2 a_1^3$  is not contained in the expansion of any starred term and hence is transferred to  $Q^{**}$ , with  $a_1$  being the entry in column  $Q$ . The row  $a_1^1 a_2^2$  is contained in  $a_2^2$  and hence is not transferred to  $Q^{**}$ .

5. On applying Steps 1, 2, 3, 4 to each group in the original tableau, we obtain the final form of  $Q^{**}$ . The tableau of  $Q^{**}$  represents the desired compactified form of  $Q$ . It can readily be verified that  $Q^{**}$  places in evidence all of the conditionally redundant questions in  $Q$ . For this reason, it will be referred to as a *maximally compact representation* of  $Q$ .

*Note 5.10.* The rows in  $Q^{**}$  correspond to the prime implicants of a switching function. For our purposes, it is not necessary to compactify  $Q^{**}$  still further by deleting the nonessential prime implicants, that is, those terms in  $Q^{**}$  which are contained in sums of expansions of some of the starred terms in  $Q^{**}$ .

*Example 5.11.* Intermediate results of the application of Algorithm 5.9 to the tableau of Table 4 are shown in Tables 6 and 7. The final result,  $Q^{**}$ , is shown in Table 8.

Given a branching questionnaire,  $Q^*$ , together with (a) the conditional probabilities of the admissible answers to each constituent question given the answers to the preceding questions; and (b) the cost of each constituent question, it is a simple matter to compute the average cost of finding an answer to  $Q$  through the use of  $Q^*$ .

**Table 7**

*Intermediate results of Algorithm 5.9 for group 2 of rows of Q*

	$Q_1$	$Q_2$	$Q_3$	$Q$
Group 2 (initial)	$a_2^1$	$a_1^2$	$a_1^3$	$a_2$
	$a_3^1$	$a_1^2$	$a_1^3$	$a_2$
	$a_1^1$	$a_1^2$	$a_2^3$	$a_2$
	$a_2^1$	$a_1^2$	$a_2^3$	$a_2$
Pass (3)	$a_2^1$	$a_1^2$	*	$a_2$

COMPUTATION OF THE AVERAGE COST OF FINDING AN ANSWER TO Q

**Table 8**

*Maximally compact representation of Q*

$Q_1$	$Q_2$	$Q_3$	$Q$
$a_1^1$	$a_1^2$	$a_1^3$	$a_1$
$a_3^1$	*	$a_2^3$	$a_1$
*	$a_2^2$	*	$a_1$
$a_3^1$	$a_1^2$	$a_1^3$	$a_2$
$a_1^1$	$a_1^2$	$a_2^3$	$a_2$
$a_2^1$	$a_1^2$	*	$a_2$

Specifically, let  $B^*$  be an algebraic representation for a branching questionnaire  $Q^*$  (see (4.3)), and let  $a_1^{j_1} \dots a_{j_k}^{j_k} / a_{\lambda_{k+1}}$  be a term in  $B^*$  corresponding to a path from the root to a leaf of  $Q^*$ . Let  $p_1^{j_1}, \dots, p_{j_k}^{j_k}$  be the probabilities associated with the branches  $a_1^{j_1}, \dots, a_{j_k}^{j_k}$  along this path, and let  $C_{j_1}, \dots, C_{j_k}$  be the costs associated with  $Q_{j_1}, \dots, Q_{j_k}$ . Then the expected cost of an answer to  $Q$  through the use of  $Q^*$  is given by



$$C_{av} = \sum p_{j_1}^1 \dots p_{j_k}^k (C_{j_1} + \dots + C_{j_k}) \quad (5.12)$$

where the summation is taken over all possible paths from the root to the leaves of  $Q^*$ .

*Example 5.13.* Consider the branching questionnaire shown in Fig. 18, in which  $C_1 = 2$ ,  $C_2 = 3$ ,  $C_3 = 1$  and the conditional probabilities have the indicated values. (Note that the probabilities associated with the root are not conditional.) Then using (5.12), we have

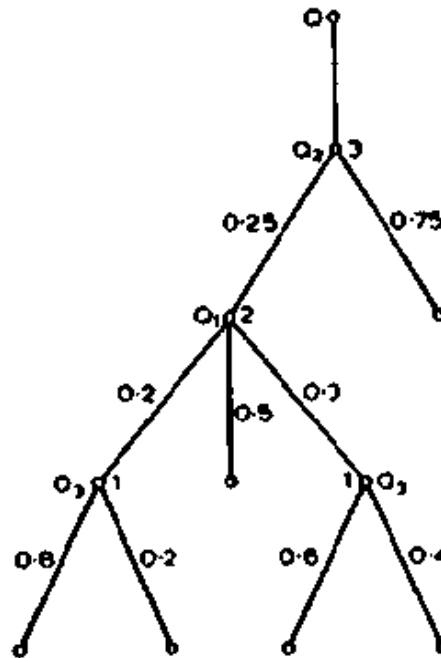

Fig. 18. Conditional probabilities and costs associated with constituent questions.

$$\begin{aligned} C_{av} &= 0.04 \times 6 + 0.01 \times 6 + 0.125 \times 5 + \\ &\quad 0.045 \times 6 + 0.03 \times 6 + 0.75 \times 3 \\ &= 3.625 \end{aligned} \quad (5.14)$$

Clearly, the determination of a realization of  $Q^*$  in the form of maximally efficient branching questionnaire — that is, a realization which minimizes  $C_{av}$  — is a non-trivial problem.

However, since in most situations the conditional probabilities and the costs of constituent questions are likely to be known imprecisely, if at all, highly approximate solutions which yield merely reasonably efficient realizations are likely to be adequate. This may well be the case, for example, in the construction of efficient branching questionnaires for purposes of medical diagnosis, in which both the costs and the probabilities of constituent questions are likely to be both highly variable and poorly defined.

We shall not dwell further upon this problem in the present paper.

## **6. Concluding remarks**

The ideas presented in this paper are merely a first step toward the development of a much more comprehensive theory of fuzzy-algorithmic definitions. We have not considered, for example, fuzzy-algorithmic definitions in which the answers to  $Q$  have the form of a probability distribution over an answer-set  $A$ . Nor have we considered more complicated types of definitions in which the object,  $x$ , is not the same for all constituent questions, or in which the order in which the questions are asked is fuzzy or probabilistic.

Although lacking in complete generality, the relatively simple types of definitions which we have discussed may find useful applications in a variety of fields. Experience with such applications may well suggest many improvements in the approach described in this paper and point to areas requiring further exploration.

The author is indebted to Richard Karp and Jeff Yang for helpful suggestions concerning the optimization of branching questionnaires.

## References

- Aho, A. V. & Ullman, J. D. (1973). *The Theory of Parsing, Translation and Compiling*. Englewood Cliffs, New Jersey: Prentice-Hall.
- Bell, D. A. (1974). Decision trees made easy. *Proceedings Second International Joint Conference on Pattern Recognition*, pp. 18 ~ 21. Copenhagen, Denmark.
- Bellman, R. E., Kalaba, R. & Zadeh, L. A. (1966). Abstraction and pattern classification. *Journal of Mathematical Analysis and Applications*, 13, 1.
- Black, M. (1963). Reasoning with loose concepts. *Dialogue*, 2, 1.
- Booth, T. L. (1968). *Sequential Machines and Automata Theory*. New York: John Wiley and Sons.
- Budacker, R. G. & Saaty, T. L. (1965). *Finite Graphs and Networks*. New York: McGraw-Hill.
- Carnap, R. (1956). *Meaning and Necessity*. Chicago: University of Chicago Press.
- Chen, C. H. (1971). Theoretical comparison of a class of feature selection criteria in pattern recognition. *IEEE Transactions on Computers*, C-20, 1054.
- Church, A. (1951). A formulation of the logic of sense and denotation. In *Structure, Method and Meaning*. New York: Liberal Arts Press.
- Clark, L. H., Jr. (1974). An economics group is the one that says if there's recession. *The Wall Street Journal*, 1, 30 August, 1974.
- Codd, E. F. (1971). Relational completeness of data base sublanguages. In

- Courant Computer Science Symposia*, 6. Englewood Cliffs, New Jersey, Prentice-Hall.
- Cole, E. J. (Ed. (1969). *Numerical Taxonomy*. New York; Academic Press.
- Domotor, Z. (1969). Probabilistic relational structures and their applications. Technical Report 144, Institute for Mathematical Studies in Social Science, Stanford University.
- Fine, K. (1973). Vagueness, truth and logic. Department of Philosophy, University of Edinburgh.
- Frege, G. (1952). In P. Geach & M. Black, Eds. *Philosophical Writings*. Oxford; Blackwell.
- Fu, K. S. (1968). *Sequential Methods in Pattern Recognition and Machine Learning*. New York; Academic Press.
- Fu, K. S. (1974). *Syntactic Methods in Pattern Recognition*. New York; Academic Press.
- Gill, A. (1962). *Introduction to the Theory of Finite-State Machines*. New York; McGraw-Hill.
- Gill, A. (1969). Finite-state systems. In L. A. Zadeh & E. Polak, Eds, *System Theory*. New York; McGraw-Hill.
- Goguen, J. A. (1969). The logic of inexact concepts. *Synthese*, 19, 325.
- Hempel, C. G. (1952). Fundamentals of concept formation in empirical science. In *International Encyclopedia of Unified Science*, 2.
- Hintikka, J., Moravcsik, J. & Suppes, P., Eds (1973). *Approaches to Natural Language*. Dordrecht, The Netherlands.
- Hyafil, L. & Rivest, R. L. (1973). Graph partitioning and constructing optimal decision trees are polynomial complete problems. IRIA Research Report 33, Le Chesnay, France.
- Jardine, N. & Sibson, R. (1971). Choice of methods for automatic classification. *The Computer Journal*, 17, 404.
- Jelinek, F. (1968). *Probabilistic Information Theory*. New York; McGraw-Hill.
- Kandel, A. (1973). On minimization of fuzzy functions. *IEEE Transactions on Computers*, C-22, 826.

- Krantz, D. H., Luce, R. D., Suppes, P. & Tversky, A. (1971). *Foundations of Measurement*. New York: Academic Press.
- Kaufmann, A. (1, 1969; 2, 3, 1975). *An Introduction to the Theory of Fuzzy Sets*. Paris: Masson et Cie. (Also, New York, Academic Press, 1975.)
- Klir, J. & Seidl, L. (1966). *Synthesis of Switching Circuits*. London: Iliffe Books Ltd.
- Kohavi, Z. (1970). *Switching and Finite Automata Theory*. New York: McGraw-Hill.
- Kohavi, A., Rivierre, J. A. & Kohavi, I. (1974). Checking experiments for sequential machines. *Information Sciences*, 7, 11.
- Lakoff, G. (1971). Linguistic and natural logic. In D. Davidson & G. Harman, Eds. *Semantics of Natural Languages*, Dordrecht, The Netherlands: D. Reidel Publishing Company.
- Lakoff, G. (1972). Hedges: A study in meaning criteria and the logic of fuzzy concepts. *Proceedings 8th Regional Meeting of Chicago Linguistic Society*. University of Chicago Linguistics Department.
- Lucas, P. *et al.* (1968). Method and notation for the formal definition of programming languages. Report TR 25. 087, IBM Laboratory, Vienna.
- Lukasiewicz, J. (1970). *Selected Works*. North-Holland Publishing Company.
- McCluskey, E. J. (1965). *Introduction to the Theory of Switching Circuits*. New York: McGraw-Hill.
- Marcovitz, A. B. & Pugsley, J. H. (1971). *An Introduction to Switching System Design*. New York: John Wiley and Sons.
- Martin, R. M. (1963). *Intension and Decision*. Englewood Cliffs, New Jersey: Prentice-Hall Inc.
- Meisel, W. S. & Michalopoulos, D. A. (1973). A partitioning algorithm with application in pattern classification and the optimization of decision trees. *IEEE Transactions on Computers*, C-22, 93.
- Minsky, M., Ed. (1968). *Semantic Information Processing*. Cambridge, Mass: MIT Press.
- Moisil, G. (1972). *Essais sur les Logiques Non-Chrysippiennes*. Bucharest:

Collected Works.

- Montalbano, M. (1962). Tables, flowcharts and program logic, *IBM Systems Journal*, 51.
- Mucciardi, A. N. & Gose, E. E. (1971). A comparison of seven techniques for choosing subsets of pattern recognition properties. *IEEE Transactions on Computers*, C-20, 1023.
- Oppenheim, A. N. (1966). *Questionnaire Design and Attitude Measurement*. New York: Basic Books.
- Picard, C. (1965). *Theorie des Questionnaires*. Paris: Gauthier-Villars.
- Pollack, S. L., Hicks, H. T., Jr. & Harrison, W. J. (1971). *Decision Tables: Theory and Practice*. New York: Wiley-Interscience.
- Quine, W. V. (1953). *From a Logical Point of View*. Cambridge, Mass.: Harvard University Press.
- Reinwald, L. T. & Soland, R. M. (1967). Conversion of limited-entry decision tables to optimal computer programs. 1 & 1. *Journal of the ACM*, 13, 339; 14, 742.
- Santos, E. (1970). Fuzzy algorithms. *Information and Control*, 17, 326.
- Scriven, M. (1958). Definitions, explanations and theories. In H. Feigl, M. Scriven & G. Maxwell, Eds. *Minnesota Studies in the Philosophy of Science*, 2. Minneapolis.
- Selkow, S. M. (1974). Diagnostic keys as a representation for context in pattern recognition. *IEEE Transactions on Computers*, C-23, 970.
- Silk, L. (1974). Recession: Some criteria missing, so far. *The New York Times*, 37, 28 August, 1974.
- Simon, H. A. & Siklossy, L., Eds (1972) *Representation and Meaning: Experiments with Information Processing Systems*. Englewood Cliffs, New Jersey, Prentice-Hall.
- Slagle, J. R. & Lee, R. C. T. (1971). Application of game searching techniques to sequential pattern recognition. *Communications of the ACM*, 14, 103.
- Sokal, R. & Sneath, P. (1963). *Principles of Numerical Taxonomy*. San Francisco: W. H. Freeman.

- Tal, A. A. (1965). The abstract synthesis of sequential machines from the answers to questions of the first kind in the questionnaire language. *Automation and Remote Control*, 26, 675.
- Tarski, A. (1956). *Logic, Semantics, Metamathematics*. Oxford; Clarendon Press.
- Tou, J. T. & Heydorn, R. P. (1967). Some approaches to optimum feature extraction. J. T. TOU, Ed. *Computer and Information Science*, II. New York; Academic Press.
- Van Frassen, B. S. (1969). Presuppositions, supervaluations and free logic. In K. Lambert, Ed. *The Logical Way of Doing Things*. New Haven; Yale University Press.
- Watanabe, S., Ed. (1969). *Methodologies of Pattern Recognition*. New York; Academic Press.
- Wegner, P. (1972). The Vienna definition language. *ACM Computing Surveys*, 4, 5.
- Zadeh, L. A. (1966). Shadows of fuzzy sets. *Problems in Transmission of Information*, 2, 37 (in Russian).
- Zadeh, L. A. (1968). Fuzzy algorithms. *Information and Control*, 12, 94.
- Zadeh, L. A. (1971a). On fuzzy algorithms. Memorandum No. ERL-M325, Electronics Research Laboratory, University of California, Berkeley.
- Zadeh, L. A. (1971b). Quantitative fuzzy semantics. *Information Sciences*, 3, 159.
- Zadeh, L. A. (1972a). Fuzzy languages and their relation to human and machine intelligence. *Proceedings of International Conference on Man and Computer*, 130. Bordeaux, France, S. Karger, Basel.
- Zadeh, L. A. (1972b). A fuzzy-set-theoretic interpretation of linguistic hedges. *Journal of Cybernetics*, 2, 4.
- Zadeh, L. A. (1973). Outline of a new approach to the analysis of complex systems and decision processes. *IEEE Transactions on Systems, Man and Cybernetics*, SMC-3, 28.
- Zadeh, L. A. (1975a). The concept of a linguistic variable and its application

- to approximate reasoning. *Information Sciences*, 8, 199 (Part I); 8, 301 (Part I); 9, 43 (Part II).
- Zadeh, L. A. (1975b). Fuzzy logic and approximate reasoning. *Synthese*, 30, 407.
- Zadeh, L. A. (1975c). Calculus of fuzzy restrictions. In L. A. ZADEH, K. S. FU, K. Tanaka & M. Shimura, Eds. *Fuzzy Sets and Their Application to Cognitive and Decision Processes*, pp. 1~39. New York; Academic Press.

## Appendix

For convenience of the reader, a brief summary of some of the relevant aspects of the theory of fuzzy sets and the linguistic approach is presented in this section. More detailed discussions of the topics touched upon in the sequel may be found in the appended list of references and related publications.

### NOTATION AND TERMINOLOGY

The symbol  $U$  denotes a universe of discourse, which may be an arbitrary collection of subjects or mathematical constructs.

If  $A$  is a finite subset of  $U$  whose elements are  $u_1, \dots, u_n$ ,  $A$  is expressed as

$$A = u_1 + \dots + u_n. \quad (A1)$$

A finite fuzzy subset of  $U$  is expressed as

$$F = \mu_1 u_1 + \dots + \mu_n u_n \quad (A2)$$

or, equivalently, as

$$F = \mu_1 / u_1 + \dots + \mu_n / u_n \quad (A3)$$

where the  $\mu_i, i = 1, \dots, n$ , represent *grades of membership* of the  $\mu_i$  in  $F$ . Unless stated to the contrary, the  $\mu_i$  are assumed to lie in the interval  $[0, 1]$ , with 0 and 1 denoting *no membership* and *full*



membership, respectively.

More generally, a fuzzy subset of  $U$  is expressed as

$$F = \int_U \mu_F(u)/u \quad (\text{A4})$$

where  $\mu_F: U \rightarrow [0, 1]$  is the *membership* (or *compatibility*) function of  $F$ , and  $\mu_F(u)/u$  is a *fuzzy singleton*. In effect, (A4) expresses  $F$  as the union of its constituent fuzzy singletons.

The points in  $U$  at which  $\mu_F(u) > 0$  constitute the *support* of  $F$ . The points at which  $\mu_F(u) = 0.5$  are the *crossover* points of  $F$ .

*Example A5.* Assume

$$U = a + b + c + d. \quad (\text{A6})$$

Then, We may have

$$A = a + b + d \quad (\text{A7})$$

and

$$F = 0.3a + 0.9b + d \quad (\text{A8})$$

as non-fuzzy and fuzzy subsets of  $U$ , respectively.

If

$$U = 0 + 0.1 + 0.2 + \dots + 1 \quad (\text{A9})$$

then a fuzzy subset of  $U$  would be expressed as, say,

$$F = 0.3/0.5 + 0.6/0.7 + 0.8/0.9 + 1/1. \quad (\text{A10})$$

If  $U = [0, 1]$ , then  $F$  might be expressed as

$$F = \int_0^1 \frac{1}{1+u^2}/u \quad (\text{A11})$$

which means that  $F$  is a fuzzy subset of the unit interval  $[0, 1]$  whose membership function is defined by

$$\mu_F(u) = \frac{1}{1+u^2}. \quad (\text{A12})$$

## OPERATION ON FUZZY SETS

If  $F$  and  $G$  are fuzzy subsets of  $U$ , their *union*,  $F+G$ , and *intersection*,  $F \cap G$ , are fuzzy subsets of  $U$  defined by

$$F+G \triangleq \int_U \mu_F(u) \vee \mu_G(u) / u \quad (\text{A13})$$

$$F \cap G \triangleq \int_U \mu_F(u) \wedge \mu_G(u) / u \quad (\text{A14})$$

where  $\vee$  and  $\wedge$  denote max and min, respectively. The *complement* of  $F$  is defined by

$$F' = \int_U (1 - \mu_F(u)) / u. \quad (\text{A15})$$

*Example A16.* For  $U$  defined by (A6) and

$$F = 0.4a + 0.9b + d \quad (\text{A17})$$

$$G = 0.6a + 0.5b \quad (\text{A18})$$

we have

$$F+G = 0.6 + 0.9b + d \quad (\text{A19})$$

$$F \cap G = 0.4a + 0.5b \quad (\text{A20})$$

$$F' = 0.6a + 0.1b + c. \quad (\text{A21})$$

The linguistic connectives *and* (conjunction) and *or* (disjunction) are identified with  $\cap$  and  $+$ , respectively. Thus,

$$F \text{ and } G \triangleq F \cap G \quad (\text{A22})$$

and

$$F \text{ or } G \triangleq F + G. \quad (\text{A23})$$

As defined by (A22) and (A23), *and* and *or* are implied to be *non-interactive* in the sense that there is no "trade-off" between their operands. When this is not the case, *and* and *or* are denoted by  $\langle \text{and} \rangle$  and  $\langle \text{or} \rangle$ , respectively, and are defined in a way that reflects the nature of the trade-off. For example, we may have

$$F \langle and \rangle G \triangleq \int_U \mu_F(u) \mu_G(u) / u \quad (A24)$$

$$F \langle or \rangle G \triangleq \int_U (\mu_F(u) + \mu_G(u) - \mu_F(u) \mu_G(u)) / u \quad (A25)$$

whose  $+$  denotes the arithmetic sum. In general, the interactive versions of *and* and *or* do not possess the simplifying properties of the connectives defined by (A22) and (A23), e. g. associativity, distributivity, etc.

If  $a$  is a real number, then  $F^a$  is defined by

$$F^a \triangleq \int_U (\mu_F(u))^a / u. \quad (A26)$$

For example, for the fuzzy set defined by (A17), we have

$$F^2 = 0.16a + 0.81b + d \quad (A27)$$

and

$$F^{1/2} = 0.63a + 0.95b + d. \quad (A28)$$

These operations may be used to approximate, very roughly, to the effect of the linguistic modifiers *very* and *more or less*. Thus,

$$\text{very } F \triangleq F^2 \quad (A29)$$

and

$$\text{more or less } F \triangleq F^{1/2}. \quad (A30)$$

If  $F_1, \dots, F_n$  are fuzzy subsets of  $U_1, \dots, U_n$ , then the *Cartesian product* of  $F_1 \dots F_n$  is a fuzzy subset of  $U_1 \times \dots \times U_n$  defined by

$$F_1 \times \dots \times F_n = \int_{U_1 \times \dots \times U_n} (\mu_{F_1}(u_1) \wedge \dots \wedge \mu_{F_n}(u_n)) / (u_1, \dots, u_n). \quad (A31)$$

As an illustration, for the fuzzy sets defined by (A7) and

(A18), we have

$$\begin{aligned} F \times G &= (0.4a + 0.9b + d) \times (0.6a + 0.5b) \\ &= 0.4/(a, a) + 0.4/(a, b) + 0.6/(b, a) \\ &\quad + 0.5/(b, b) + 0.6/(d, a) + 0.5/(d, b) \end{aligned} \quad (\text{A32})$$

which is a fuzzy subset of  $(a+b+c+d) \times (a+b+c+d)$ .

### FUZZY RELATIONS

An  $n$ -ary fuzzy relation  $R$  in  $U_1 \times \dots \times U_n$  is a fuzzy subset of  $U_1 \times \dots \times U_n$ . The *projection of  $R$  on  $U_{i_1} \times \dots \times U_{i_k}$* , where  $(i_1, \dots, i_k)$  is a subsequence of  $(1, \dots, n)$  is a relation in  $U_{i_1} \times \dots \times U_{i_k}$  defined by

$$\text{Proj } R \text{ on } U_{i_1} \times \dots \times U_{i_k} \triangleq \int_{U_{i_1} \times \dots \times U_{i_k}} \bigvee u_{j_1}, \dots, u_{j_l} \mu_R(u_1, \dots, u_n) / (u_1, \dots, u_n) \quad (\text{A33})$$

where  $(j_1, \dots, j_l)$  is the sequence complementary to  $(i_1, \dots, i_k)$  (e. g. if  $n = 6$  then  $(1, 3, 6)$  complementary to  $(2, 4, 5)$ ), and  $\bigvee u_{j_1}, \dots, u_{j_l}$  denotes the supremum over  $U_{j_1} \times \dots \times U_{j_l}$ .

If  $R$  is a fuzzy subset of  $U_{i_1}, \dots, U_{i_k}$ , then its *cylindrical extension* in  $U_1 \times \dots \times U_n$  is a fuzzy subset of  $U_1 \times \dots \times U_n$  defined by

$$\bar{R} = \int_{U_{i_1} \times \dots \times U_{i_k}} \mu_R(u_{i_1}, \dots, u_{i_k}) / (u_1, \dots, u_n). \quad (\text{A34})$$

In terms of their cylindrical extensions, the *composition* of two binary relation  $R$  and  $S$  (in  $U_1 \times U_2$  and  $U_2 \times U_3$ , respectively) is expressed by

$$R \circ S = \text{Proj } \bar{R} \cap \bar{S} \text{ on } U_1 \times U_3. \quad (\text{A35})$$

where  $\bar{R}$  and  $S$  are the cylindrical extensions of  $R$  and  $S$  in  $U_1 \times U_2 \times U_3$ . Similarly, if  $R$  is a binary relation in  $U_1 \times U_2$  and  $S$  is a unary relation in  $U_2$ , their composition is given by

$$R \circ S = \text{Proj } R \cap \bar{S} \text{ on } U_1, \quad (\text{A36})$$

*Example A37.* Let  $R$  be defined by the right-hand member of (A32) and

$$S = 0.4a + b + 0.8d. \quad (\text{A38})$$

when

$$\text{Proj } R \text{ on } U_1 (\stackrel{\Delta}{=} a + b + c + d) = 0.4a + 0.6b + 0.6d \quad (\text{A39})$$

and

$$R \circ S = 0.4a + 0.5b + 0.5d. \quad (\text{A40})$$

## LINGUISTIC VARIABLES

Informally a linguistic variable,  $\chi$ , is a variable whose values are words or sentences in a natural or artificial language. For example, if *age* is interpreted as a linguistic variable, then its *term-set*,  $T(\chi)$ , that is, the set of linguistic values, might be

$$\begin{aligned} T(\text{age}) = & \text{young} + \text{old} + \text{very young} + \text{not young} + \\ & \text{very old} + \text{very very young} + \\ & \text{rather young} + \text{more or less young} + \dots \quad (\text{A41}) \end{aligned}$$

where each of the terms in  $T(\text{age})$  is a label of a fuzzy subset of a universe of discourse, say  $U = [0, 100]$ .

A linguistic variable is associated with two rules: (a) a *syntactic rule*, which defines the well-formed sentences in  $T(\chi)$ ; and (b) a *semantic rule*, by which the meaning of the terms in  $T(\chi)$  may be determined. If  $X$  is a term in  $T(\chi)$ , then its *meaning* (in a denotational sense) is a subset of  $U$ . A *primary term* in

$T(\chi)$  is a term whose meaning is a *primary fuzzy set*, that is, a term whose meaning must be defined a priori, and which serves as a basis for the computation of the meaning of the non-primary terms in  $T(\chi)$ . For example, the primary terms in (A41) are *young* and *old*, whose meaning might be defined by their respective compatibility functions  $\mu_{young}$  and  $\mu_{old}$ . From these, then, the meaning—or, equivalently, the compatibility functions—of the non-primary terms in (A41) may be computed by the application of a semantic rule. For example, employing (A29) and (A30) we have

$$\mu_{very\ young} = (\mu_{young})^2 \quad (A42)$$

$$\mu_{more\ or\ less\ old} = (\mu_{old})^{1/2} \quad (A43)$$

$$\mu_{not\ very\ young} = 1 - (\mu_{young})^2. \quad (A44)$$

For illustration, plots of the compatibility functions of these terms are shown in Fig. A1.

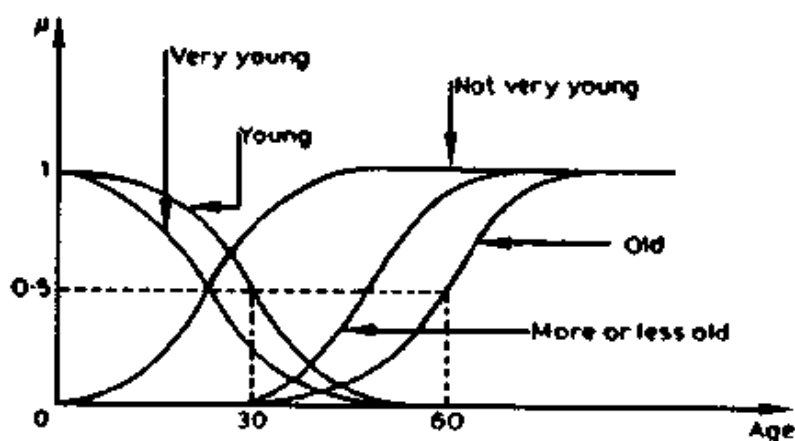

Fig. A1. Compatibility functions of *young*, *old*, *very young*, *more or less old*, *not very young* (not to scale).

## THE EXTENSION PRINCIPLE

Let  $f$  be a mapping from  $U$  to  $V$ . Thus,

$$v = f(u) \quad (\text{A45})$$

where  $u$  and  $v$  are generic elements of  $U$  and  $V$ , respectively.

Let  $F$  be a fuzzy subset of  $U$  expressed as

$$F = \mu_1 u_1 + \dots + \mu_n u_n \quad (\text{A46})$$

or more generally

$$F = \int_U \mu_F(u) / u \quad (\text{A47})$$

By the extension principle (Zadeh, 1975a), the image of  $F$  under  $f$  is given by

$$f(F) = \mu_1 f(u_1) + \dots + \mu_n f(u_n) \quad (\text{A48})$$

or, more generally,

$$f(F) = \int_U \mu_F(u) / f(u) \quad (\text{A49})$$

Similarly, if  $f$  is a mapping from  $U \times V$  to  $W$ , and  $F$  and  $G$  are fuzzy subsets of  $U$  and  $V$ , respectively, then

$$f(F, G) = \int_W (\mu_F(u) \wedge \mu_G(v)) / f(u, v) \quad (\text{A50})$$

*Example A51.* Assume that  $f$  is the operation of squaring. Then, for the set defined by (A10), we have

$$\begin{aligned} & f(0.3/0.5 + 0.6/0.7 + 0.8/0.9 + 1/1) \\ &= 0.3/0.25 + 0.6/0.49 + 0.8/0.81 + 1/1. \end{aligned} \quad (\text{A51})$$

Similarly, for the binary operation  $\vee$  ( $\triangleq$  max) we have

$$\begin{aligned} & (0.9/0.1 + 0.2/0.5 + 1/1) \vee (0.3/0.2 + 0.8/0.6) \\ &= 0.3/0.2 + 0.2/0.5 + 0.3/1 + 0.8/0.6 + 0.2/0.6 + 0.8/0.6. \end{aligned} \quad (\text{A52})$$

# Fuzzy Sets And Information Granularity

## 1. Introduction

Much of the universality, elegance and power of classical mathematics derives from the assumption that real numbers can be characterized and manipulated with infinite precision. Indeed, without this assumption, it would be much less simple to define what is meant by the zero of a function, the rank of a matrix, the linearity of a transformation or the stationarity of a stochastic process.

It is well-understood, of course, that in most real-world applications the effectiveness of mathematical concepts rests on their robustness, which in turn is dependent on the underlying continuity of functional dependencies [1]. Thus, although no physical system is linear in the idealized sense of the term, it may be regarded as such as an approximation. Similarly, the concept of a normal distribution has an operational meaning only in an approximate and, for that matter, not very well-defined sense.

There are many situations, however, in which the finiteness of the resolving power of measuring or information gathering devices cannot be dealt with through an appeal to continuity. In such cases, the information may be said to be *granular* in the sense that the data points within a granule have to be dealt with as a whole rather than individually.



Taken in its broad sense, the concept of information granularity occurs under various guises in a wide variety of fields. In particular, it bears a close relation to the concept of aggregation in economics; to decomposition and partition—in the theory of automata and system theory; to bounded uncertainties—in optimal control [2], [3]; to locking granularity—in the analysis of concurrencies in data base management systems [4]; and to the manipulation of numbers as intervals—as in interval analysis [5]. In the present paper, however, the concept of information granularity is employed in a stricter and somewhat narrower sense which is defined in greater detail in Sec. 2. In effect, the main motivation for our approach is to define the concept of information granularity in a way that relates it to the theories of evidence of Shafer [6], Dempster [7], Smets [8], Cohen [9], Shackle [10] and others, and provides a basis for the construction of more general theories in which the evidence is allowed to be fuzzy in nature.

More specifically, we shall concern ourselves with a type of information granularity in which the data granules are characterized by propositions of the general form

$$g \triangleq X \text{ is } G \text{ is } \lambda \quad (1.1)$$

in which  $X$  is a variable taking values in a universe of discourse  $U$ .  $G$  is a fuzzy subset of  $U$  which is characterized by its membership function  $\mu_G$ , and the qualifier  $\lambda$  denotes a fuzzy probability (or likelihood). Typically, but not universally, we shall assume that  $U$  is the real line (or  $R^n$ ),  $G$  is a convex fuzzy subset of  $U$  and  $\lambda$  is a fuzzy subset of the unit interval. For example:

$g \triangleq X \text{ is small is likely}$

$g \triangleq X \text{ is not very large is very unlikely}$

$g \triangleq X \text{ is much larger than } Y \text{ is unlikely}$

We shall not consider data granules which are characterized by propositions in which the qualifier  $\lambda$  is a fuzzy possibility or fuzzy truth-value.

In a general sense, a *body of evidence* or, simply, *evidence*, may be regarded as a collection of propositions. In particular, the evidence is *granular* if it consists of a collection of propositions,

$$E = \{g_1, \dots, g_N\} \quad (1.2)$$

each of which is of the form (1.1). Viewed in this perspective, Shafer's theory relates to the case where the constituent granules in (1.2) are crisp (nonfuzzy) in the sense that, in each  $g_i$ ,  $G_i$  is a nonfuzzy set and  $\lambda_i$  is a numerical probability, implying that  $g_i$  may be expressed as

$$g_i \triangleq \text{"Prob}\{X \in G_i\} = p_i\text{"} \quad (1.3)$$

where  $p_i, i = 1, \dots, N$ , is the probability that the value of  $X$  is contained in  $G$ . In the theories of Cohen and Shackle, a further restriction is introduced through the assumption that the  $G_i$  are nested, i. e.,  $G_1 \subset G_2 \subset \dots \subset G_N$ . As was demonstrated by Suppes and Zanotti [11] and Nguyen [12], in the analysis of evidence of the form (1.3) it is advantageous to treat  $E$  as a random relation.

Given a collection of granular bodies of evidence  $E = \{E_1, \dots, E_k\}$ , one may ask a variety of questions the answers to which depend on the data resident in  $E$ . The most basic of these questions—which will be the main focus of our attention in the

sequel—is the following:

Given a body of evidence  $E = \{g_1, \dots, g_N\}$  and an arbitrary fuzzy subset  $Q$  of  $U$ , what is the probability—which may be fuzzy or nonfuzzy—that  $X$  is  $Q$ ? In other words, from the propositions

$$g_1 \triangleq X \text{ is } G_1 \text{ is } \lambda_1 \quad (1.4)$$

.....

$$g_N \triangleq X \text{ is } G_N \text{ is } \lambda_N$$

we wish to deduce the value of?  $\lambda$  in the question

$$q \triangleq X \text{ is } Q \text{ is? } \lambda \quad (1.5)$$

As a concrete illustration, suppose that we have the following granular information concerning the age of Judy ( $X \triangleq \text{Age}(\text{Judy})$ )

$$g_1 \triangleq \text{Judy is very young is unlikely}$$

$$g_2 \triangleq \text{Judy is young is likely} \quad (1.6)$$

$$g_3 \triangleq \text{Judy is old is very unlikely}$$

The question is: What is the probability that Judy is not very young; or, equivalently, What is the value of?  $\lambda$  in

$$q \triangleq \text{Judy is not very young is? } \lambda$$

In cases where  $E$  consists of two or more distinct bodies of evidence, an important issue relates to the manner in which the answer to (1.5)—based on the information resident in  $E$ —may be composed from the answers based on the information resident in each of the constituent bodies of evidence  $E_1, \dots, E_t$ . We shall consider this issue very briefly in Sec. 3.

In the theories of Dempster and Shafer, both the evidence

and the set  $Q$  in (1.5) are assumed to be crisp, and the question that is asked is: What are the bounds on the probability  $\lambda$  that  $X \in Q$ ? The lower bound,  $\lambda^*$ , is referred to as the *lower probability* and is defined by Shafer to be the *degree of belief* that  $X \in Q$ . An extension of the concepts of lower and upper probabilities to the more general case of fuzzy granules will be described in Sec. 3.

As will be seen in the sequel, the theory of fuzzy sets and, in particular, the theory of possibility, provides a convenient conceptual framework for dealing with information granularity in a general setting. Viewed in such a setting, the concept of information granularity assumes an important role in the analysis of imprecise evidence and thus may aid in contributing to a better understanding of the complex issues arising in credibility analysis, model validation and, more generally, those problem areas in which the information needed for a decision or system performance evaluation is incomplete or unreliable.

## **2. Information granularity and possibility distributions**

Since the concept of information granularity bears a close relation to that of a possibility distribution, we shall begin our exposition with a brief review of those properties of possibility distributions which are of direct relevance to the concepts introduced in the following sections.

Let  $X$  be a variable taking values in  $U$ , with a generic value of  $X$  denoted by  $u$ . Informally, a possibility distribution,  $\Pi_X$ , is a fuzzy relation in  $U$  which acts as an elastic constraint on the values that may be assumed by  $X$ . Thus, if  $\Pi_X$  is the membership function of  $\Pi_X$ , we have

$$\text{Poss}\{X=u\} = \pi_X(u), u \in U \quad (2.1)$$

where the left-hand member denotes the possibility that  $X$  may take the value  $u$  and  $\pi_X(u)$  is the grade of membership of  $u$  in  $\Pi_X$ . When used to characterize  $\Pi_X$ , the function  $\pi_X: U \rightarrow [0, 1]$  is referred to as a *possibility distribution function*.

A possibility distribution,  $\Pi_X$ , may be induced by physical constraints or, alternatively, it may be epistemic in nature, in which case  $\Pi_X$  is induced by a collection of propositions—as described at a later point in this section. A simple example of a possibility distribution which is induced by a physical constraint is the number of tennis balls that can be placed in a metal box. In this case,  $X$  is the number in question and  $\Pi_X(u)$  is a measure of the degree of ease (by some specified mechanical criterion) with which  $u$  balls can be squeezed into the box.

As a simple illustration of an epistemic possibility distribution, let  $X$  be a real-valued variable and let  $p$  be the proposition

$$p \triangleq a \leq X \leq b$$

where  $[a, b]$  is an interval in  $\mathbb{R}^{\text{①}}$ . In this case, the possibility distribution induced by  $p$  is the uniform distribution defined by

$$\begin{aligned} \Pi_X(u) &= 1 \quad \text{for } a \leq u \leq b \\ &= 0 \quad \text{elsewhere.} \end{aligned}$$

Thus, given  $p$  we can assert that

$$\begin{aligned} \text{Poss}\{X=u\} &= 1 \quad \text{for } u \text{ in } [a, b] \\ &= 0 \quad \text{elsewhere.} \end{aligned}$$

More generally, as shown in [16], a proposition of the form

---

① A more detailed discussion of possibility theory may be found in [13]~[15].

$$p \triangleq N \text{ is } F \quad (2.2)$$

where  $F$  is a fuzzy subset of the cartesian product  $U = U_1 \times \dots \times U_n$  and  $N$  is the name of a variable, a proposition or an object, induces a possibility distribution defined by the *possibility assignment equation*

$$(N \text{ is } F) \rightarrow \Pi_{(X_1, \dots, X_n)} = F \quad (2.3)$$

where the symbol  $\rightarrow$  stands for "translates into", and  $X \triangleq (X_1, \dots, X_n)$  is an  $n$ -ary variable which is implicit or explicit in  $p$ . For example,

$$(a) \quad X \text{ is small} \rightarrow \Pi_X = \text{SMALL} \quad (2.4)$$

where SMALL, the denotation of *small*, is a specified fuzzy subset of  $[0, \infty)$ . Thus, if the membership function of SMALL is expressed as  $\mu_{\text{SMALL}}$ , then (2.4) implies that

$$\text{Poss}\{X = u\} = \mu_{\text{SMALL}}(u), u \in [0, +\infty). \quad (2.5)$$

More particularly, if—in the usual notation—

$$\text{SMALL} = 1/0 + 1/1 + 0.8/2 + 0.6/3 + 0.5/4 + 0.3/5 + 0.1/6 \quad (2.6)$$

then

$$\text{Poss}\{X = 3\} = 0.6$$

and likewise for other values of  $u$ .

Similarly,

$$(b) \quad \text{Dan is tall} \rightarrow \Pi_{\text{Height}(\text{Dan})} = \text{TALL} \quad (2.7)$$

where the variable  $\text{Height}(\text{Dan})$  is implicit in the proposition "Dan is tall" and TALL is a fuzzy subset of the interval  $[0, 220]$  (with the height assumed to be expressed in centimeters).

$$(c) \quad \text{John is big} \rightarrow \Pi_{(\text{Height}(\text{John}), \text{Weight}(\text{John}))} = \text{BIG} \quad (2.8)$$

where BIG is a fuzzy binary relation in the product space  $[0,$

220]  $\times$  [0, 150] (with height and weight expressed in centimeters and kilograms, respectively) and the variables  $X_1 \triangleq$  Height (John),  $X_2 \triangleq$  Weight (John) are implicit in the proposition "John is big."

In a more general way, the translation rules associated with the meaning representation language PRUF [16] provide a system for computing the possibility distributions induced by various types of propositions. For example

$$X \text{ is not very small} \rightarrow \Pi_X = (\text{SMALL}^2)' \quad (2.9)$$

where  $\text{SMALL}^2$  is defined by

$$\mu_{\text{SMALL}^2} = (\mu_{\text{SMALL}})^2 \quad (2.10)$$

and ' denotes the complement. Thus, (2.10) implies that the possibility distribution function of  $X$  is given by

$$\pi_X(u) = 1 - \mu_{\text{SMALL}^2}(u). \quad (2.11)$$

In the case of conditional propositions of the form  $p \triangleq$  If  $X$  is  $F$  then  $Y$  is  $G$ , the possibility distribution that is induced by  $p$  is a *conditional possibility distribution* which is defined by<sup>①</sup>

$$\text{If } X \text{ is } F \text{ then } Y \text{ is } G \rightarrow \Pi_{(Y|X)} = \bar{F}' \cup \bar{G} \quad (2.12)$$

where  $\Pi_{(Y|X)}$  denotes the conditional possibility distribution of  $Y$  given  $X$ ,  $F$  and  $G$  are fuzzy subsets of  $U$  and  $V$ , respectively,  $\bar{F}$  and  $\bar{G}$  are the cylindrical extensions of  $F$  and  $G$  in  $U \times V$ ,  $\cup$  is the union, and the conditional possibility distribution function of  $Y$  given  $X$  is expressed by

---

① There are a number of alternative ways in which  $\Pi_{(Y|X)}$  may be defined in terms of  $F$  and  $G$  [17], [18], [19]. Here we use a definition which is consistent with the relation between the extended concepts of upper and lower probabilities as described in Sec. 3.

$$\pi_{(Y|X)}(v|u) = (1 - \mu_F(u)) \vee \mu_G(v), u \in U, v \in V \quad (2.13)$$

where  $\mu_F$  and  $\mu_G$  are the membership functions of  $F$  and  $G$ , and  $\vee \triangleq \max$ . In connection with (2.12), it should be noted that

$$\pi_{(Y|X)}(v|u) = \text{Poss}(Y=v|X=u) \quad (2.14)$$

whereas

$$\pi_{(X,Y)}(u,v) = \text{Poss}(X=u, Y=v). \quad (2.15)$$

A concept which is related to that of a conditional possibility distribution is the concept of a *conditional possibility measure* [13]. Specifically, let  $\Pi_X$  be the possibility distribution induced by the proposition

$$p \triangleq X \text{ is } G,$$

and let  $F$  be a fuzzy subset of  $U$ . Then, the *conditional possibility measure* of  $F$  with respect to the possibility distribution  $\Pi_X$  is defined by

$$\text{Poss}(X \text{ is } F | X \text{ is } G) = \sup_U (\mu_F(u) \wedge \mu_G(u)). \quad (2.16)$$

It should be noted that the left-hand member of (2.16) is a set function whereas  $\Pi_{(Y|X)}$  is a fuzzy relation defined by (2.12).

The foregoing discussion provides us with the necessary background for defining some of the basic concepts relating to information granularity. We begin with the concept of a *fuzzy granule*.

*Definition.* Let  $X$  be a variable taking values in  $U$  and let  $G$  be a fuzzy subset of  $U$ . (Usually, but not universally,  $U = R^n$ , and  $G$  is a convex fuzzy subset of  $U$ .) A *fuzzy granule*,  $g$ , in  $U$  is induced (or characterized) by a proposition of the form

$$g \triangleq X \text{ is } G \text{ is } \lambda \quad (2.17)$$

where  $\lambda$  is a fuzzy probability which is characterized by a



possibility distribution over the unit interval. For example, if  $U = R^1$ , we may have

$$g \triangleq X \text{ is small is not very likely} \quad (2.18)$$

where the denotation of *small* is a fuzzy subset **SMALL** of  $R^1$  which is characterized by its membership function  $\mu_{\text{SMALL}}$ , and the fuzzy probability *not very likely* is characterized by the possibility distribution function

$$\pi(v) = 1 - \mu_{\text{LIKELY}}^2(v), v \in [0, 1] \quad (2.19)$$

in which  $\mu_{\text{LIKELY}}$  is the membership function of the denotation of *likely* and  $v$  is a numerical probability in the interval  $[0, 1]$ .

If the proposition  $p \triangleq X \text{ is } G$  is interpreted as a fuzzy event [20], then (2.17) may be interpreted as the proposition

$$\text{Prob}\{X \text{ is } G\} \text{ is } \lambda$$

which by (2.3) translates into

$$\Pi_{\text{Prob}}\{X \text{ is } G\} = \lambda. \quad (2.20)$$

Now, the probability of the fuzzy event  $p \triangleq X \text{ is } G$  is given by [20]

$$\text{Prob}\{X \text{ is } G\} = \int_U p_X(u) \mu_G(u) du \quad (2.21)$$

where  $p_X(u)$  is the probability density associated with  $X$ . Thus, the translation of (2.17) may be expressed as

$$g \triangleq X \text{ is } G \text{ is } \lambda \rightarrow \pi(p_X) = \mu_\lambda \left( \int_U p_X(u) \mu_G(u) du \right) \quad (2.22)$$

which signifies that  $g$  induces a possibility distribution of the probability distribution of  $X$ , with the possibility of the probability density  $p_X$  given by the right-hand member of (2.22).

For example, in the case of (2.18), we have

$$X \text{ is small is not very likely} \rightarrow \pi(p_X)$$

$$= 1 - \mu_{\text{LIKELY}}^2 \left( \int_U p_X(u) \mu_{\text{SMALL}}(u) du \right). \quad (2.23)$$

As a special case of (2.17), a fuzzy granule may be characterized by a proposition of the form

$$g \triangleq X \text{ is } G \quad (2.24)$$

which is not probability-qualified. To differentiate between the general case (2.17) and the special case (2.24), fuzzy granules which are characterized by propositions of the form (2.17) will be referred to as  $\pi p$ -granules (signifying that they correspond to possibility distributions of probability distributions), while those corresponding to (2.24) will be described more simply as  $\pi$ -granules.

A concept which we shall need in our analysis of bodies of evidence is that of a *conditioned  $\pi$ -granule*. More specifically, if  $X$  and  $Y$  are variables taking values in  $U$  and  $V$ , respectively, then a *conditioned  $\pi$ -granule* in  $V$  is characterized by a conditional proposition of the form

$$g \triangleq \text{If } X=u \text{ then } Y \text{ is } G \quad (2.25)$$

where  $G$  is a fuzzy subset of  $V$  which is dependent on  $u$ . From this definition it follows at once that the possibility distribution induced by  $g$  is defined by the possibility distribution function

$$\pi_{(Y|X)}^{(v|u)} \triangleq \text{Poss} \{Y=v | X=u\} = \mu_G(v). \quad (2.26)$$

An important point which arises in the characterization of fuzzy granules is that the same fuzzy granule may be induced by distinct propositions, in which case the propositions in question are said to be *semantically equivalent* [16]. A particular and yet useful case of semantic equivalence relates to the effect of negation in (2.17) and may be expressed as ( $\longleftrightarrow$  denotes semantic

equivalence)

$$X \text{ is } G \text{ is } \lambda \longleftrightarrow X \text{ is not } G \text{ is ant } \lambda \quad (2.27)$$

where  $\text{ant } \lambda$  denotes the antonym of  $\lambda$  which is defined by

$$\mu_{\text{ant } \lambda}(v) = \mu_{\lambda}(1-v), v \in [0,1]. \quad (2.28)$$

Thus, the membership function of  $\text{ant } \lambda$  is the mirror image of that of  $\lambda$  with respect to the midpoint of the interval  $[0,1]$ .

To verify (2.27) it is sufficient to demonstrate that the propositions in question induce the same fuzzy granule. To this end, we note that

$$\begin{aligned} X \text{ is not } G \text{ is ant } \lambda \rightarrow \pi(p_X) &= \mu_{\text{ant } \lambda} \left( \int_U p_X(u) (1 - \mu_G(u)) du \right) \\ &= \mu_{\text{ant } \lambda} \left( 1 - \int_U p_X(u) \mu_G(u) du \right) \\ &= \mu_{\lambda} \left( \int_U p_X(u) \mu_G(u) du \right) \end{aligned} \quad (2.29)$$

which upon comparison with (2.22) establishes the semantic equivalence expressed by (2.27).

In effect, (2.27) indicates that replacing  $G$  with its negation may be compensated by replacing  $\lambda$  with its antonym. A simple example of an application of this rule is provided by the semantic equivalence

$$X \text{ is small is likely} \longleftrightarrow X \text{ is not small is unlikely} \quad (2.30)$$

in which *unlikely* is interpreted as the antonym of *likely*.

A concept that is related to and is somewhat weaker than that of semantic equivalence is the concept of *semantic entailment* [16]. More specifically, if  $g_1$  and  $g_2$  are two propositions such that the fuzzy granule induced by  $g_1$  is contained in the fuzzy granule induced by  $g_2$ , then  $g_2$  is *semantically entailed* by  $g_1$  or, equivalently,  $g_1$  *semantically entails*  $g_2$ . To establish the relation

of containment it is sufficient to show that

$$\pi_1(p_X) \leq \pi_2(p_X), \text{ for all } p_X \quad (2.31)$$

where  $\pi_1$  and  $\pi_2$  are the possibilities corresponding to  $g_1$  and  $g_2$ , respectively.

As an illustration, it can readily be established that ( $\vdash$  denotes semantic entailment)

$$X \text{ is } G \text{ is } \lambda \vdash X \text{ is very } G \text{ is } {}^2\lambda \quad (2.32)$$

or, more concretely,

$$X \text{ is small is likely } \vdash X \text{ is very small is } {}^2\text{likely} \quad (2.33)$$

where the left-square of  $\lambda$  is defined by

$$\mu_{\lambda}(v) = \mu_{\lambda}(\sqrt{v}), v \in [0, 1]$$

and  $\mu_{\lambda}$  is assumed to be monotone nondecreasing. Intuitively, (2.32) signifies that an intensification of  $G$  through the use of the modifier *very* may be compensated by a dilation (broadening) of the fuzzy probability  $\lambda$ .

To establish (2.32), we note that

$$X \text{ is } G \text{ is } \lambda \rightarrow \pi_1(p_X) = \mu_{\lambda}\left(\int_U p_X(u) \mu_G(u) du\right) \quad (2.34)$$

$$\begin{aligned} X \text{ is very } G \text{ is } {}^2\lambda \rightarrow \pi_2(p_X) &= \mu_{\lambda}\left(\int_U p_X(u) \mu_G^2(u) du\right) \quad (2.35) \\ &= \mu_{\lambda}\left(\sqrt{\int_U p_X(u) \mu_G^2(u) du}\right). \end{aligned}$$

Now, by Schwarz's inequality

$$\sqrt{\int_U p_X(u) \mu_G^2(u) du} \geq \int_U p_X(u) \mu_G(u) du \quad (2.36)$$

and since  $\mu_{\lambda}$  is monotone nondecreasing, we have

$$\pi_1(p_X) \leq \pi_2(p_X)$$

which is what we wanted to demonstrate.

### 3. Analysis of granular evidence

As was stated in the introduction, a *body of evidence* or, simply, *evidence*,  $E$ , may be regarded as a collection of propositions

$$E = \{g_1, \dots, g_N\}. \quad (3.1)$$

In particular, evidence is *granular* if its constituent propositions are characterizations of fuzzy granules.

For the purpose of our analysis it is necessary to differentiate between two types of evidence which will be referred to as *evidence of the first kind* and *evidence of the second kind*.

Evidence of the first kind is a collection of fuzzy  $\pi p$ -granules of the form

$$g_i \triangleq Y \text{ is } G_i \text{ is } \lambda_i \quad i=1, \dots, N \quad (3.2)$$

where  $Y$  is a variable taking values in  $V$ ,  $G_1, \dots, G_N$  are fuzzy subsets of  $V$  and  $\lambda_1, \dots, \lambda_N$  are fuzzy probabilities.

Evidence of the second kind is a probability distribution of conditioned  $\pi$ -granules of the form

$$g_i \triangleq Y \text{ is } G_i. \quad (3.3)$$

Thus, if  $X$  is taken to be a variable which ranges over the index set  $\{1, \dots, N\}$ , then we assume to know (a) the probability distribution  $p_X = \{p_1, \dots, p_N\}$ , where

$$p_i \triangleq \text{Prob}\{X=i\}, \quad i=1, \dots, N \quad (3.4)$$

and (b) the conditional possibility distribution  $\Pi_{(Y|X)}$ , where

$$\Pi_{(Y|X=i)} = G_i \quad i=1, \dots, N. \quad (3.5)$$

In short, we may express evidence of the second kind in a

symbolic form as

$$E = \{ p_X, \Pi_{(Y|X)} \}$$

which signifies that the evidence consists of  $p_X$  and  $\Pi_{(Y|X)}$ , rather than  $p_X$  and  $p_{(Y|X)}$  (conditional probability distribution of  $Y$  given  $X$ ), which is what is usually assumed to be known in the traditional probabilistic approaches to the analysis of evidence. Viewed in this perspective, the type of evidence considered in the theories of Dempster and Shafer is evidence of the second kind in which the  $G_i$  are crisp sets and the probabilities  $p_1, \dots, p_n$  are known numerically.

In the case of evidence of the first kind, our main concern is with obtaining an answer to the following question. Given  $E$ , find the probability,  $\lambda$ , or, more specifically, the possibility distribution of the probability  $\lambda$ , that  $Y$  is  $Q$ , where  $Q$  is an arbitrary fuzzy subset of  $V$ .

In principle, the answer to this question may be obtained as follows.

First, in conformity with (2.20), we interpret each of the constituent propositions in  $E$ ,

$$g_i \triangleq Y \text{ is } G_i \text{ is } \lambda_i, \quad i = 1, \dots, N \quad (3.6)$$

as the assignment of the fuzzy probability  $\lambda_i$  to the fuzzy event  $g_i \triangleq Y \text{ is } G_i$ . Thus, if  $p(\cdot)$  is the probability density associated with  $Y$ , then in virtue of (2.22) we have

$$\pi_i(p) = \mu_{\lambda_i} \left( \int_V p(v) \mu_{G_i}(v) dv \right) \quad (3.7)$$

where  $\pi_i(p)$  is the possibility of  $p$  given  $g_i$ , and  $\mu_{\lambda_i}$  and  $\mu_{G_i}$  are the membership functions of  $\lambda_i$  and  $G_i$ , respectively.

Since the evidence  $E = \{g_1, \dots, g_N\}$  may be regarded as the

conjunction of the propositions  $g_1, \dots, g_N$ , the possibility of  $p(\cdot)$  given  $E$  may be expressed as

$$\pi(p) = \pi_1(p) \wedge \dots \wedge \pi_N(p) \quad (3.8)$$

where  $\wedge \triangleq \min$ . Now, for a  $p$  whose possibility is expressed by (3.8), the probability of the fuzzy event  $q \triangleq X$  is  $Q$  is given by

$$\rho(p) = \int_V p(v) \mu_Q(v) dv. \quad (3.9)$$

Consequently, the desired possibility distribution of  $\rho(p)$  may be expressed in a symbolic form as the fuzzy set [21]

$$\lambda = \int_{[0,1]} \pi(p) / \rho(p) \quad (3.10)$$

in which the integral sign denotes the union of singletons  $\pi(p) / \rho(p)$ .

In more explicit terms, (3.10) implies that if  $\rho$  is a point in the interval  $[0,1]$ , then  $\mu_\lambda(\rho)$ , the grade of membership of  $\rho$  in  $\lambda$  or, equivalently, the possibility of  $\rho$  given  $\lambda$ , is the solution of the variational problem

$$\mu_\lambda(\rho) = \max_p (\pi_1(p) \wedge \dots \wedge \pi_N(p)) \quad (3.11)$$

subject to the constraint

$$\rho = \int_V p(v) \mu_Q(v) dv. \quad (3.12)$$

In practice, the solution of problems of this type would, in general, require both discretization and approximation, with the aim of reducing (3.11) to a computationally feasible problem in nonlinear programming. In the longer run, however, a more effective solution would be a "fuzzy hardware" implementation which would yield directly a linguistic approximation to  $\lambda$  from the specification of  $q$  and  $E$ .

It should be noted that if we were concerned with a special case of evidence of the first kind in which the probabilities  $\lambda$  are numerical rather than fuzzy, then we could use as an alternative to the technique described above the maximum entropy principle of Jaynes [22] or its more recent extensions [23] ~ [26]. In application to the problem in question, this method would first yield a probability density  $p(\cdot)$  which is a maximum entropy fit to the evidence  $E$ , and then, through the use of (3.12), would produce a numerical value for  $\lambda$ .

A serious objection that can be raised against the use of the maximum entropy principle is that, by constructing a unique  $p(\cdot)$  from the incomplete information in  $E$ , it leads to artificially precise results which do not reflect the intrinsic imprecision of the evidence and hence cannot be treated with the same degree of confidence as the factual data which form a part of the database. By contrast, the method based on the use of possibility distributions leads to conclusions whose imprecision reflects the imprecision of the evidence from which they are derived and hence are just as credible as the evidence itself.

Turning to the analysis of evidence of the second kind, it should be noted that, although there is a superficial resemblance between the first and second kinds of evidence, there is also a basic difference which stems from the fact that the fuzzy granules in the latter are  $\pi$ -granules which are conditioned on a random variable. In effect, what this implies is that evidence of the first kind is *conjunctive* in nature, as is manifested by (3.8). By contrast, evidence of the second kind is *disjunctive*, in the sense that the collection of propositions in  $E$  should be interpreted as



the disjunctive statement:  $g_1$  with probability  $\lambda_1$  or  $g_2$  with probability  $\lambda_2$  or ... or  $g_N$  with probability  $\lambda_N$ .

As was stated earlier, evidence of the second kind may be expressed in the equivalent form

$$E = \{p_x, \Pi_{(Y|X)}\}$$

where  $X$  is a random variable which ranges over the index set  $U = \{1, \dots, N\}$  and is associated with a probability distribution  $p_x = \{p_1, \dots, p_N\}$ ; and  $\Pi_{(Y|X)}$  is the conditional possibility distribution of  $Y$  given  $X$ , where  $Y$  is a variable ranging over  $V$  and the distribution function of  $\Pi_{(Y|X)}$  is defined by

$$\pi_{(Y|X)}(v|i) \triangleq \text{Poss}(Y=v|X=i), i \in U, v \in V. \quad (3.13)$$

For a given value of  $X$ ,  $X = i$ , the conditional possibility distribution  $\Pi_{Y|X}$  defines a fuzzy subset of  $V$  which for consistency with (3.2) is denoted by  $G_i$ . Thus,

$$\Pi_{(Y|X=i)} = G_i, i = 1, \dots, N, \quad (3.14)$$

and more generally

$$\Pi_{(Y|X)} = G_X. \quad (3.15)$$

As was pointed out earlier, the theories of Dempster and Shafer deal with a special case of evidence of the second kind in which the  $G_i$  and  $Q$  are crisp sets and the probabilities  $p_1, \dots, p_N$  are numerical. In this special case, the event  $q \triangleq Y \in Q$  may be associated with two probabilities: the *lower probability*  $\lambda_*$  which is defined-in our notation-as

$$\lambda_* \triangleq \text{Prob}\{\Pi_{(Y|X)} \subset Q\} \quad (3.16)$$

and the *upper probability*  $\lambda^*$  which is defined as<sup>①</sup>

$$\lambda^* \triangleq \text{Prob} \{ \Pi_{(Y|X)} \cap Q \neq \emptyset \} \quad (\emptyset \triangleq \text{empty set}). \quad (3.17)$$

The concepts of upper and lower probabilities do not apply to the case where the  $G_i$  and  $Q$  are fuzzy sets. For this case, we shall define two more general concepts which are related to the modal concepts of necessity and possibility and which reduce to  $\lambda$ , and  $\lambda^*$  when the  $G_i$  and  $Q$  are crisp.

For our purposes, it will be convenient to use the expressions  $\text{sup } F$  and  $\text{inf } F$  as abbreviations defined by<sup>②</sup>

$$\text{sup } F \triangleq \text{sup}_v \mu_F(v), v \in V \quad (3.18)$$

$$\text{inf } F \triangleq \text{inf}_v \mu_F(v), v \in V \quad (3.19)$$

where  $F$  is a fuzzy subset of  $V$ . Thus, using this notation, the expression for the conditional possibility measure of  $Q$  given  $X$  may be written as (see (2.16))

$$\begin{aligned} \text{Poss} \{ Y \text{ is } Q | X \} &= \text{Poss} \{ Y \text{ is } Q | Y \text{ is } G_X \} \\ &= \text{sup} (Q \cap G_X) \end{aligned} \quad (3.20)$$

Since  $X$  is a random variable, we can define the expectation of  $\text{Poss} \{ Y \text{ is } Q | X \}$  with respect to  $X$ . On denoting this expectation by  $E\Pi(Q)$ , we have

$$\begin{aligned} E\Pi(Q) &\triangleq E_X \text{Poss} \{ Y \text{ is } Q | X \} \\ &= \sum_i p_i \text{sup} (Q \cap G_i) \end{aligned} \quad (3.21)$$

① It should be noted that we are not normalizing the definitions of  $\lambda$ , and  $\lambda^*$  -as is done in the papers by Dempster and Shafer-by dividing the right-hand members of (3.16) and (3.17) by the probability that  $\Pi_{(Y|X)}$  is not an empty set. As is pointed out in [27], the normalization in question leads to counterintuitive results.

② The definitions in question bear a close relation to the definitions of universal and existential quantifiers in  $L_{\text{Aleph}_1}$  logic [28].

We shall adopt the *expected possibility*,  $E\Pi(Q)$ , as a generalization of the concept of upper probability. Dually, the concept of lower probability may be generalized as follows.

First, we define the *conditional certainty* (or *necessity*) of the proposition  $q \triangleq Y \text{ is } Q$  given  $X$  by

$$\text{Cert}\{Y \text{ is } Q|X\} \triangleq 1 - \text{Poss}\{Y \text{ is not } Q|X\}. \quad (3.22)$$

Next, in view of the identities

$$\begin{aligned} 1 - \text{sup}(F \cap G) &= \text{inf}((F \cap G)') \\ &= \text{inf}(F' \cup G') \\ &= \text{inf}(G \Rightarrow F') \end{aligned} \quad (3.23)$$

where the implication  $\Rightarrow$  is defined by (see (2.13))

$$G \Rightarrow F' \triangleq G' \cup F' \quad (3.24)$$

we can rewrite the right-hand member of (3.22) as

$$\text{Cert}\{Y \text{ is } Q|X\} = \text{inf}\{G_X \Rightarrow Q\}. \quad (3.25)$$

Finally, on taking the expectation of both sides of (3.22) and (3.25), we have

$$\begin{aligned} \text{EC}(Q) &\triangleq E_X \text{Cert}\{Y \text{ is } Q|X\} \\ &= \sum_i p_i \text{inf}(G_i \Rightarrow Q) \\ &= 1 - E\Pi(Q') \end{aligned} \quad (3.26)$$

As defined by (3.26), the expression  $\text{EC}(Q)$ , which represents the *expected certainty* of the conditional event  $(Y \text{ is } Q|X)$ , may be regarded as a generalization of the concept of lower probability.

The set functions  $E\Pi(Q)$  and  $\text{EC}(Q)$  may be interpreted as fuzzy measures. However, in general, these measures are neither normed nor additive. Instead,  $E\Pi(Q)$  and  $\text{EC}(Q)$  are, respectively, superadditive and subadditive in the sense that, for

any fuzzy subsets  $Q_1$  and  $Q_2$  of  $V$ , we have

$$EC(Q_1 \cup Q_2) \geq EC(Q_1) + EC(Q_2) - EC(Q_1 \cap Q_2) \quad (3.27)$$

and

$$E\Pi(Q_1 \cup Q_2) \leq E\Pi(Q_1) + E\Pi(Q_2) - E\Pi(Q_1 \cap Q_2). \quad (3.28)$$

It should be noted that these inequalities generalize the superadditive and subadditive properties of the measures of belief and plausibility in Shafer's theory.

The inequalities in question are easy to establish. Taking (3.28), for example, we have

$$\begin{aligned} E\Pi(Q_1 \cup Q_2) &= \sum_i p_i \sup_V \{ (\mu_{Q_1}(v) \vee \mu_{Q_2}(v)) \wedge \mu_{G_i}(v) \} \\ &= \sum_i p_i \sup_V \{ \mu_{Q_1}(v) \wedge \mu_{G_i}(v) \vee \mu_{Q_2}(v) \wedge \mu_{G_i}(v) \} \\ &= \sum_i p_i \{ \sup_V \{ \mu_{Q_1}(v) \wedge \mu_{G_i}(v) \} \vee \sup_V \{ \mu_{Q_2}(v) \wedge \mu_{G_i}(v) \} \} \end{aligned} \quad (3.29)$$

Now, using the identity ( $(a, b \triangleq$  real numbers)

$$a \vee b = a + b - a \wedge b \quad (3.30)$$

the right-hand member of (3.29) may be rewritten as

$$\begin{aligned} E\Pi(Q_1 \cup Q_2) &= \sum_i p_i \{ \sup_V \{ \mu_{Q_1}(v) \wedge \mu_{G_i}(v) \} + \sup_V \{ \mu_{Q_2}(v) \wedge \mu_{G_i}(v) \} \\ &\quad - \{ \sup_V \{ \mu_{Q_1}(v) \wedge \mu_{G_i}(v) \} \wedge \sup_V \{ \mu_{Q_2}(v) \wedge \mu_{G_i}(v) \} \} \} \end{aligned} \quad (3.31)$$

Furthermore, from the min-max inequality

$$\sup_V f(v) \wedge \sup_V g(v) \geq \sup_V (f(v) \wedge g(v)) \quad (3.32)$$

it follows that

$$\begin{aligned} \sup_V \{ \mu_{Q_1}(v) \wedge \mu_{G_i}(v) \} \wedge \sup_V \{ \mu_{Q_2}(v) \wedge \mu_{G_i}(v) \} \\ \geq \sup_V \{ \mu_{Q_1}(v) \wedge \mu_{Q_2}(v) \wedge \mu_{G_i}(v) \} \end{aligned} \quad (3.33)$$

and hence that

$$E\Pi(Q_1 \cup Q_2) \leq \sum_i p_i \sup_v (\mu_{Q_1}(v) \wedge \mu_{G_i}(v)) + \sum_i p_i \sup_v (\mu_{Q_2}(v) \wedge \mu_{G_i}(v)) - \sum_i p_i \sup_v (\mu_{Q_1}(v) \wedge \mu_{Q_2}(v) \wedge \mu_{G_i}(v)). \quad (3.34)$$

Finally, on making use of (3.21) and the definition of  $Q_1 \cap Q_2$ , we obtain the inequality

$$E\Pi(Q_1 \cup Q_2) \leq E\Pi(Q_1) + E\Pi(Q_2) - E\Pi(Q_1 \cap Q_2) \quad (3.35)$$

which is what we set out to establish.

The superadditive property of  $EC(Q)$  has a simple intuitive explanation. Specifically, because of data granularity, if  $Q_1$  and  $Q_2$  are roughly of the same size as the granules  $G_1, \dots, G_N$ , then  $EC(Q_1)$  and  $EC(Q_2)$  are likely to be small, while  $E(Q_1 \cup Q_2)$  may be larger because the size of  $Q_1 \cup Q_2$  is likely to be larger than that of  $G_1, \dots, G_N$ . For the same reason, with the increase in the relative size of  $Q_1$  and  $Q_2$ , the effect of granularity is likely to diminish, with  $EC(Q)$  tending to become additive in the limit.

In the foregoing analysis, the probabilities  $p_1, \dots, p_N$  were assumed to be numerical. This, however, is not an essential restriction, and through the use of the extension principle [21], the concepts of expected possibility and expected certainty can readily be generalized, at least in principle, to the case where the probabilities in question are fuzzy or linguistic. Taking the expression for  $E\Pi(Q)$ , for example,

$$E\Pi(Q) = \sum_i p_i \sup(Q \cap G_i) \quad (3.36)$$

and assuming that the  $p_i$  are characterized by their respective possibility distribution functions  $\pi_1, \dots, \pi_N$ , the determination of the possibility distribution function of  $E\Pi(Q)$  may be reduced to the solution of the following variational problem

$$\pi(z) \triangleq \max_{p_1, \dots, p_N} \pi_1(p_1) \wedge \dots \wedge \pi_N(p_N) \quad (3.37)$$

subject to

$$z = p_1 \sup(Q \cap G_1) + \dots + p_N \sup(Q \cap G_N)$$

$$p_1 + \dots + p_N = 1$$

which upon solution yields the possibility,  $\pi(z)$ , of a numerical value,  $z$ , of  $E\Pi(Q)$ . Then, a linguistic approximation to the possibility distribution would yield an approximate value for  $\Pi_{E\Pi}(Q)$  expressed as, say, *not very high*.

As was alluded to already, a basic issue in the analysis of evidence relates to the manner in which two or more distinct bodies of evidence may be combined. In the case of evidence of the second kind, for example, let us assume for simplicity that we have two bodies of evidence of the form

$$E = \{E_1, E_2\} \quad (3.38)$$

in which

$$E_1 = \{P_{X_1}, \Pi_{(Y|X_1)}\} \quad (3.39)$$

$$E_2 = \{P_{X_2}, \Pi_{(Y|X_2)}\} \quad (3.40)$$

where  $Y$  takes values in  $V$ , while  $X_1$  and  $X_2$  range over the index sets  $U_1 = \{1, \dots, N_1\}$  and  $U_2 = \{1, \dots, N_2\}$ , and are associated with the joint probability distribution  $P_{(X_1, X_2)}$  which is characterized by

$$p_{i,j} \triangleq \text{Prob}\{X_1 = i, X_2 = j\}. \quad (3.41)$$

For the case under consideration, the expression for the expected possibility of the fuzzy event  $q \triangleq Y$  is  $Q$  given  $E_1$  and  $E_2$  becomes

$$E\Pi(Q) = E_{(X_1, X_2)} \text{Poss}\{Y \text{ is } Q | (X_1, X_2)\} \quad (3.42)$$

$$= \sum_{i,j} p_{i,j} \sup(Q \cap G_i \cap H_j)$$

where

$$\Pi_{(Y|X_1 = i)} \triangleq G_i \quad (3.43)$$

and

$$\Pi_{G_i | X_2 = y} \triangleq H_j, \quad (3.44)$$

The rule of combination of evidence developed by Dempster [7] applies to the special case of (3.42) in which the sets  $G_i$  and  $H_j$  are crisp and  $X_1$  and  $X_2$  are independent. In this case, from the knowledge of  $E\Pi(Q)$  (or  $EC(Q)$ ) for each of the constituent bodies of evidence and  $Q \subset V$ , we can determine the probability distributions of  $X_1$  and  $X_2$  and then use (3.42) to obtain  $E\Pi(Q)$  for the combined evidence. Although simple in principle, the computations involved in this process tend to be rather cumbersome. Furthermore, as is pointed out in [27], there are some questions regarding the validity of the normalization employed by Dempster when

$$G_i \cap H_j = \theta \quad (3.45)$$

for some  $i, j$ , and the probability of the event " $Y$  is  $\theta$ " is positive.

#### 4. Concluding remarks

Because of its substantial relevance to decision analysis and model validation, analysis of evidence is likely to become an important area of research in the years ahead.

It is a fact of life that much of the evidence on which human decisions are based is both fuzzy and granular. The concepts and techniques outlined in this paper are aimed at providing a basis for a better understanding of how such evidence may be analyzed in systematic terms.

Clearly, the mathematical problems arising from the

granularity and fuzziness of evidence are far from simple. It may well be the case that their full solution must await the development of new types of computing devices which are capable of performing fuzzy computations in a way that takes advantage of the relatively low standards of precision which the results of such computations are expected to meet.

## References

- [1] A. N. Tikhonov and V. Ya. Arsenin, *Methods of Solution of [1]-Posed Problems*, Nauka, Moscow, 1974.
- [2] S. Gutman, "Uncertain dynamical systems — a Lyapounov min-max approach," *IEEE Trans. on Automatic Control*, AC-24, 437~443, 1979.
- [3] F. Schlaepfer and F. Schweppe, "Continuous-time state estimation under disturbances bounded by convex sets," *IEEE Trans. on Automatic Control*, AC-17, 197~205, 1972.
- [4] D. R. Ries and M. R. Stonebraker, "Locking granularity revisited," ERL Memorandum M78/71, Electronics Research Laboratory, University of California, Berkeley, 1978.
- [5] R. E. Moore, *interval Analysis*, Prentice-Hall, Englewood Cliffs, N. J. , 1966.
- [6] G. Shafer, *A Mathematical Theory of Evidence*, Princeton University Press, 1976.
- [7] A. P. Dempster, "Upper and lower probabilities induced by a multivalued mapping," *Ann. Math. Statist.* 38, 325~329, 1967.
- [8] P. Smets, "Un modele mathematique-statistique simulant le processus du diagnostic medicale," Free University of Brussels, 1978.
- [9] L. J. Cohen, *The Implications of Induction*, Methuen, London, 1970.



- [10] G. L. S. Shackle, *Decision, Order and Time in Human Affairs*, Cambridge University Press, Cambridge, 1961.
- [11] P. Suppes and M. Zanotti, "On using random relations to generate upper and lower probabilities," *Synthese* 36, 427~440, 1977.
- [12] H. T. Nguyen, "On random sets and belief functions," *J. Math. Anal. Appl.* 65, 531~542, 1978.
- [13] L. A. Zadeh, "Fuzzy sets as a basis for a theory of possibility," *Fuzzy Sets and Systems* 1, 3~28, 1978.
- [14] H. T. Nguyen, "On conditional possibility distributions," *Fuzzy Sets and Systems* 1, 299~309, 1978.
- [15] E. Hisdal, "Conditional possibilities: independence and noninteraction," *Fuzzy Sets and Systems* 1, 283~297, 1978.
- [16] L. A. Zadeh, "PRUF—a meaning representation language for natural languages," *Int. J. Man-Machine Studies* 10, 395~460, 1978.
- [17] M. Mizumoto, S. Fukame and K. Tanaka, "Fuzzy reasoning methods by Zadeh and Mamdani, and improved methods," *Proc. Third Workshop on Fuzzy Reasoning*, Queen Mary College, London, 1978.
- [18] B. S. Sembi and E. H. Mamdani, "On the nature of implication in fuzzy logic," *Proc. 9th international Symposium on Multiple-Valued Logic*, Bath, England, 143~151, 1979.
- [19] W. Bandler and L. Kohout, "Application of fuzzy logics to computer protection structures," *Proc. 9th International Symposium on Multiple-Valued Logic*, Bath, England, 200~207, 1979.
- [20] L. A. Zadeh, "Probability measures of fuzzy events," *J. Math. Anal. Appl.* 23, 421~427, 1968.
- [21] L. A. Zadeh, "The concept of a linguistic variable and its application to approximate reasoning, Part 1," *Information Sciences* 8, 199~249, 1975; Part I, *Information Sciences* 8, 301~357, 1975; Part II, *Information Sciences* 9, 43~80, 1975.
- [22] E. T. Jaynes, "Information theory and statistical mechanics," Parts I and II, *Physical Review* 106, 620~630; 108, 171~190, 1957.

- [23] S. Kullback, *Information Theory and Statistics*, John Wiley, New York, 1959.
- [24] M. Tribus, *Rational Descriptions, Decisions and Designs*, Pergamon Press, New York, 1969.
- [25] J. E. Shore and R. W. Johnson, "Axiomatic derivation of the principle of maximum entropy and the principle of minimum cross-entropy," NRI Memorandum Report 3~898, Naval Research Laboratory, Washington, D. C., 1978.
- [26] P. M. Williams, "Bayesian conditionalization and the principle of minimum information," School of Mathematical and Physical Sciences, The University of Sussex, England, 1978.
- [27] L. A. Zadeh, "On the validity of Dempster's rule of combination of evidence," Memorandum M79/24, Electronics Research Laboratory, University of California, Berkeley, 1979.
- [28] N. Rescher, *Many-Valued Logic*, McGraw-Hill, New York, 1969.
- [29] J. Kampe de Fériet and B. Forte, "Information et probabilité," *Comptes Rendus Acad. Sci. A*-265, 110~114, 142~146, 350~353, 1967.
- [30] M. Sugeno, "Theory of fuzzy integrals and its applications," Tokyo Institute of Technology, 1974.
- [31] T. Terano and M. Sugeno, "Conditional fuzzy measures and their applications," in *Fuzzy Sets and Their Application to Cognitive and Decision Processes* (L. A. Zadeh, K. S. Fu, K. Tanaka and M. Shimura, eds.), 151~170, 1975.
- [32] E. Sanchez, "On possibility-qualification in natural languages," Memorandum M77/28, Electronics Research Laboratory, University of California, Berkeley, 1977.
- [33] P. M. Williams, "On a new theory of epistemic probability (review of G. Shafer, *A Mathematical Theory of Evidence*)," *Brit. J. for the Philosophy of Science* 29, 375~387, 1978.
- [34] P. Suppes, "The measurement of belief," *J. Roy. Statist. Soc. B* 36, 160~175, 1974.

- [35] K. M. Colby, "Simulations of belief systems," in *Computer Models of Thought and Language* (R. C. Schank and K. M. Colby, eds. ), W. Freeman, San Francisco, 1973.
- [36] B. C. Bruce, "Belief systems and language understanding," N. I. H. Report CBM-TR-41, Rutgers University, 1975.
- [37] R. P. Abelson, "The structure of belief systems," in *Computer Models of Thought and Language* (R. C. Schank and K. M. Colby, eds. ), W. Freeman, San Francisco, 1973.
- [38] R. D. Rosenkrantz, *Inference, Method and Decision*, D. Reidel, Dordrecht, 1977.
- [39] N. Rescher, *Plausible Reasoning*, Van Gorcum, Amsterdam, 1976.
- [40] A. Tversky and D. Kahneman, "Judgment under uncertainty: heuristics and biases," *Science* 185, 1124~1131, 1974.
- [41] G. Banon, "Distinctions between several types of fuzzy measures," *Proc. Int. Colloquium on the Theory and Applications of Fuzzy Sets*, University of Marseille, Marseille, 1978.
- [42] I. J. Good, "Subjective probability as the measure of a non-measurable set," in *Logic, Methodology and Philosophy of Science; Proceedings of the 1960 International Congress* (E. Nagel, P. Suppes and A. Tarski, eds. ), Stanford University Press, 1962.

# **Outline of a Computational Approach to Meaning and Knowledge Representation Based on the Concept of a Generalized Assignment Statement**

## **1. Introduction**

The concept of an assignment statement plays a central role in programming languages. Could it play a comparable role in the representation of knowledge expressed in a natural language? In our paper, we generalize the concept of an assignment statement in a way that makes it a convenient point of departure for representing the meaning of propositions in a natural language. Furthermore, it can be shown—though we do not stress this issue in the present paper—that the concept of a generalized assignment statement provides an effective computational framework for a system of inference with propositions expressed in a natural language. In some ways, this system is simpler and more direct than predicate-logic-based systems in which it is the concept of a logical form—rather than a generalized assignment statement—that plays a central role [7, 16, 23, 24, 25, 26, 28, 30, 31].

The approach described in the present paper may be viewed as an evolution of our earlier work on test-score semantics and canonical forms [36, 38, 41]. In test-score semantics, a proposition,  $p$ , is viewed as a collection of elastic constraints, and its meaning is represented as a procedure which tests, scores, and

aggregates the constraints associated with  $p$ , yielding a vector test score which serves as a measure of compatibility between  $p$  and what is referred to as an *explanatory database*. The main advantage of test-score semantics over the classical approaches to meaning representation such as truthconditional semantics, possible-world semantics and model-theoretic semantics [3, 8, 17, 20, 21, 30, 31], lies in its greater expressive power and, in particular, its ability to deal with fuzzy predicates such as *young*, *intelligent*, *near*, etc. [2, 5, 11, 18, 22, 32, 36, 44]; fuzzy quantifiers exemplified by *most*, *several*, *few*, *often*, *usually*, etc. [10, 33, 40]; predicate modifiers such as *very*, *more or less*, *quite*, *extremely*, etc. [35, 44]; and fuzzy truth-values exemplified by *quite true*, *almost true*, and *mostly false* [36].

The concept of a generalized assignment statement serves to place in a sharper focus the representation of a proposition in a natural language as a collection of elastic constraints. More specifically, in its generic form, the generalized assignment statement may be expressed as

$$X \text{ is}_r \Omega, \quad (1.1)$$

where  $X$  is the constrained variable;  $\Omega$  is the constraining object, usually an  $n$ -ary predicate; and *is<sub>r</sub>* is a copula in which  $r$  is a variable which defines the role of  $\Omega$  in relation to  $X$ . The usual values of  $r$  are:  $d$ , standing for *disjunctive*;  $c$ , standing for *conjunctive*;  $p$ , standing for *probabilistic*;  $g$ , standing for *granular*; and  $h$ , standing for *hybrid*. Since in most cases the value of  $r$  is  $d$ , it is convenient to adopt the convention that *is<sub>d</sub>* may be written more simply as *is*.

In (1.1), the generalized assignment statement is

unconditioned. More generally, the statement may be *conditioned*, in which case it may be expressed as

$$X \text{ is } r_1 \Omega_1 \text{ if } Z \text{ is } r_2 \Omega_2, \quad (1.2)$$

in which  $Z$  is a conditioning variable,  $\Omega_2$  is an object which constrains  $Z$ ; and  $r_1$  and  $r_2$  are variables which define the roles of  $\Omega_1$  and  $\Omega_2$  in relation to  $X$  and  $Z$ , respectively. In general, both  $X$  and  $Z$  may be vector-valued.

### DISJUNCTIVE AND CONJUNCTIVE CONSTRAINTS<sup>①</sup>

As a simple illustration of a disjunctive constraint, if  $X$  is a variable which takes values in a universe of discourse  $U$  and  $A$  is a subset,  $A$ , of  $U$ , then the generalized assignment statement

$$X \text{ is } A \quad (1.3)$$

signifies that the value of  $X$  is one of the elements of  $A$ . In this sense,  $A$  may be interpreted as the *possibility distribution* of  $X$ , that is, the set of its possible values [11, 36, 39].

More concretely, consider the proposition

*p*: *Mary left home sometime between four and five in the afternoon.*

In this case, if  $X$  is taken to be the time at which Mary left home, the meaning of  $p$  may be represented as the generalized assignment statement

$$X \text{ is } d [4\text{pm}, 5\text{pm}], \quad (1.4)$$

or more simply, as

$$X \text{ is } [4\text{pm}, 5\text{pm}],$$

---

① The discussion of disjunctive and conjunctive constraints in the present paper is based on earlier discussions in [36, 38]. Recent results may be found in [34].

in which the interval [4pm, 5pm] plays the role of a unary predicate.

As an illustration of a conjunctive constraint, consider the proposition

*p: Mary was at home from four to five in the afternoon.*

In this case, if  $X$  is taken to be the time at which Mary was at home, the meaning of  $p$  may be represented as:

$$X \text{ is } c [4\text{pm}, 5\text{pm}]. \quad (1.5)$$

Note that in this case  $X$  takes *all* values in the interval [4pm, 5pm].

The assignment statements (1.4) and (1.5) differ from conventional assignment statements in that the assignment is set-valued rather than point-valued. Furthermore, although the assigned sets are identical in (1.4) and (1.5), they play different roles in relation to  $X$ . The possibility that the same constraining object may constrain  $X$  in different ways is the principal motivating reason for employing in (1.1) a copula of the form *isr* in which the variable  $r$  specifies the role of  $\Omega$  in relation to  $X$ .

In the examples considered so far, the constraint induced by  $\Omega$  is inelastic in the sense that there are only two possibilities: either the constraint is satisfied or it is not, which is characteristic of constraints associated with assignment statements in programming languages. In the case of natural languages, however, the constraints are usually elastic rather than inelastic, which implies that  $\Omega$  is a fuzzy predicate. As a simple example, in the case of the proposition

*p: Mary is young*

the constrained variable,  $X$ , is the age of Mary, and the predicate

*young* may be interpreted as an elastic constraint on  $X$  characterized by the function  $\mu_{young}: [0, 100] \rightarrow [0, 1]$ , which associates with each numerical value,  $u$ , of the variable *Age* the degree to which  $u$  fits the definition of *young* in the context in which  $p$  is asserted. In this sense,  $1 - \mu_{young}(u)$  may be interpreted as the degree to which the predicate *young* must be stretched to fit  $u$ .

### PROBABILISTIC CONSTRAINTS

As was alluded to already, a proposition  $p$  may have different generalized assignment statement representations depending on the intended meaning of  $p$ . For example, the proposition

$$p: \textit{Madeleine is tall} \quad (1.6)$$

may be represented as a disjunctive statement

$$X \textit{ is TALL}, \quad (1.7)$$

in which  $X \triangleq \textit{Height}(\textit{Madeleine})$  and *TALL* is a unary fuzzy relation which is the denotation of the fuzzy predicate *tall*.<sup>①</sup> The fuzzy relation *TALL* is characterized by its membership function  $\mu_{TALL}$ , which associates with each numerical value of height,  $h$ , the degree  $\mu_{TALL}(h)$ , to which  $h$  fits the intended meaning of *tall*. Equivalently, *TALL* may be interpreted as the possibility distribution,  $\Pi_X$ , of  $X$ . In this interpretation, (1.7) may be represented as

$$\Pi_X = \textit{TALL}, \quad (1.8)$$

---

① Here and in the sequel, denotations of predicates are expressed in uppercase symbols. The symbol  $\triangleq$  stands for *is defined to be*.



with the understanding that the possibility that  $X$  can take  $h$  as a value is given by

$$\pi_X(h) \triangleq \text{Poss}\{X=h\} = \mu_{TALL}(h), \quad (1.9)$$

where  $\pi_X$  represents the *possibility distribution function* of  $X$ .

Alternatively, the proposition *Madeleine is tall* may be interpreted as a characterization of the probability distribution of the variable *Height(Madeleine)*. If this is the intended meaning of (1.6), then the corresponding generalized assignment statement would be probabilistic, i. e. ,

$$X \text{ is } p \text{ } TALL, \quad (1.10)$$

in which  $r = p$ , and  $TALL$  is a probability distribution. Thus, if  $P_X$  is the probability distribution of  $X$ , then (1.10) may be represented as

$$P_X = TALL \quad (1.11)$$

It should be noted that in the absence of a specification of the value of the copulavariabale  $r$ , the proposition

$$p: \text{Madeleine is tall}$$

may be interpreted as a possibilistic constraint on  $X \triangleq \text{Height(Madeleine)}$ , as in (1.7), or a probabilistic constraint, as in (1.10). We shall assume that, unless it is specification stated that the intended interpretation of a proposition,  $p$ , is probabilistic or conjunction  $p$  should be interpreted as a possibilistic, i. e. , disjunctive constraint. This understanding reflects the assumption that in natural languages the constraints implicit in proposition are preponderantly possibilistic in nature.

A related point that should be noted is that in the possibilistic interpretation of (1.6), the value of  $\pi_X(h)$  or,

equivalently,  $\mu_{TALL}(h)$ , may be interpreted as the conditional probability of the truth of the proposition *Madeleine is tall* for a given  $h$ . In the context of a voting model, this is equivalent to viewing  $\mu_{TALL}(h)$  as the proportion of voters who would vote that *Madeleine is tall* given that her height is  $h$  [13, 14]. Although these interpretations are of help in developing a better understanding of the properties of the membership function, it is simplest to regard  $\mu_{TALL}(h)$  as the degree to which  $h$  fits the predicate *tall* in a given context, or, equivalently, as  $1 - \sigma$ , where  $\sigma$  is the degree to which the predicate *tall* must be stretched to fit  $h$ .

## GRANULAR CONSTRAINTS

In the case of a granular constraint, the generalized assignment statement assumes the form

$$X \text{ is } G, \quad (1.12)$$

where  $X$  is an  $n$ -ary variable  $X = (X_1, \dots, X_n)$ , and  $G$  is a *granular distribution* expressed as

$$G = \{(p_1, G_1), \dots, (p_k, G_k)\}, \quad (1.13)$$

in which  $p_1, \dots, p_k$  are positive numbers in the interval  $[0, 1]$  which add up to unity,<sup>①</sup> and the  $G_j, j=1, \dots, k$ , are distinct fuzzy subsets of a universe of discourse  $U$ .

The generalized assignment statement (1.12) may be interpreted as a summary of  $n$  possibilistic assignment statements, each of which involves a component of  $X$ , i. e. ,

---

① A more detailed discussion of the concept of a granular constraint and its role in the Dempster-Shafer theory of evidence may be found in [37].

$$X_1 \text{ is } G_{j_1} \quad (1.14)$$

...

$$X_n \text{ is } G_{j_k},$$

in which each  $G_{j_s}, s=1, \dots, k$ , is one of the  $G_j$ . In this collection of statements,  $p_j$  is the proportion of  $X$ 's which are  $G_j$ .

As an illustration, consider the following proposition

*p*: There are twenty residents in an apartment house; seven are old, five are young and the rest are middle-aged. (1.15)

In this case,  $X$ , is the age of  $i$ th resident,  $i=1, \dots, 20$ ;  $n=20$ ;  $k=3$ ;  $G_1 \triangleq \text{OLD}$ ;  $G_2 \triangleq \text{YOUNG}$ ;  $G_3 \triangleq \text{MIDDLE-AGED}$ ;  $p_1=7/20$ ;  $p_2=5/20$ ; and  $p_3=8/20$ .

## HYBRID CONSTRAINTS

A hybrid constraint is associated with a generalized assignment statement of the form

$$X \text{ is } \Omega, \quad (1.16)$$

and may be viewed as the result of combination of two or more generalized assignment statements of different types, e. g. ,

$$\frac{\begin{array}{l} X \text{ is } r_1 \Omega_1 \\ X \text{ is } r_2 \Omega_2 \end{array}}{X \text{ is } \Omega}.$$

An important special case of a hybrid constraint is associated with the concept of a hybrid number [19]. In this case, the constraint on  $X$  is characterized by two generalized assignment statements of the form

$$Y \text{ is } A \quad (1.17)$$

$$Z \text{ is } P$$

and the relation

$$X=Y+Z.$$

in which  $A$  and  $P$  are, respectively, possibility and probability distributions, and  $X$  is defined to be the sum of  $Y$  and  $Z$ . In terms of  $A$  and  $P$ , the constraining object  $\Omega$  in (1.16) may be viewed equivalently as a *probabilistic set* [15], a random fuzzy set [14], or a fuzzy random variable [27].

## 2. Meaning representation

As was stated already, the basic idea underlying test-score semantics is that a proposition in a natural language may be interpreted as a collection of elastic constraints. Thus, by expressing the meaning of a proposition,  $p$ , in the form of a generalized assignment statement, we are, in effect, answering two basic questions: (a) What is the constrained variable  $X$  in  $p$ , and (b) What is the constraint,  $\Omega$ , to which  $X$  is subjected?

In more concrete terms, the process of representing the meaning of a proposition,  $p$ , in the form of a generalized assignment statement,  $X \text{ isr } A$ , involves three basic steps. ①

1. Constructing a collection of relations  $\{R_1, \dots, R_k\}$ , in terms of which the meaning of  $p$  is to be represented. The meaning of each of these relations is assumed to be known, and each relation is assumed to be characterized by its name, the names of its attributes and the domain of each attribute. For our purposes, it is convenient to refer to the collection  $\{R_1, \dots, R_k\}$  as an *explanatory database* or *ED* for short, and to regard each relation as an elastic constraint on the values of its attributes. It should

---

① For simplicity, our discussion of these steps is limited to the possibilistic case.

be noted that the concept of an explanatory database is related, but is not identical, to that of a collection of possible worlds [8, 17, 29, 21, 31].

2. Identifying the variable  $X$  which is constrained by  $p$  and constructing a defining procedure which computes  $X$  for a given explanatory database.

3. Constructing a procedure which computes the constraint  $A$  as a function of  $ED$ .

To illustrate this process, consider the proposition

*p: Over the past few years Naomi earned far more than all of her close friends put together.*

To represent the meaning of this proposition, assume that the explanatory database consists of the following relations (+ should be read as *and*):

$$\begin{aligned}
 ED = & INCOME[Name; Amount; Year] + \\
 & FRIEND[Name1, Name2, \mu] + \\
 & FEW[Number; \mu] + \\
 & FARMORE[Income1; Income2, \mu]. \quad (2.1)
 \end{aligned}$$

In this database, the relation *INCOME* associates with each  $Name_j, j = 1, \dots, n$ ,  $Name_j$ 's income in year  $Year_i, i = 1, 2, 3, \dots$ , counting backward from the present; in *FRIEND*,  $\mu$  is the degree to which  $Name1$  is a friend of  $Name2$ ; in *FEW*,  $\mu$  is the degree to which the value of the attribute *Number* fits the definition of *few*; and in *FARMORE*,  $\mu$  is the degree to which  $Income1$  is far more than  $Income2$ .

Next, we have to construct a procedure for computing the constrained variable  $X$ . Assume that  $X$  is the total income of Naomi over the past few years. Then, the following procedure

will compute  $X$ .

1. Find Naomi's income,  $IN_i$ , in  $Year_i$ ,  $i = 1, 2, 3, \dots$ , counting backward from present. In symbols,

$$IN_i =_{Amount} INCOME(Name = Naomi; Year = Year_i), \quad (2.2)$$

which signifies that  $Name$  is bound to Naomi,  $Year$  to  $Year_i$ , and the resulting relation is projected on the domain of the attribute  $Amount$ , yielding the value of  $Amount$  corresponding to the values assigned to the attributes  $Name$  and  $Year$ .

2. Test the constraint induced by  $FEW$ ;

$$\mu_i =_r FEW[Year = Year_i], \quad (2.3)$$

which signifies that the variable  $Year$  is bound to  $Year_i$  and the corresponding value of  $\mu$  is read by projecting on the domain of  $\mu$ .

3. Compute Naomi's total income,  $X$ , during the past few years:

$$X = \sum_i \mu_i IN_i, \quad (2.4)$$

in which the  $\mu_i$  plays the role of weighting coefficients. Thus we are tacitly assuming that the total income earned by Naomi during a fuzzily specified interval of time is obtained by (a) weighting Naomi's income in year  $Year_i$  by the degree to which  $Year_i$  satisfies the constraint induced by  $FEW$ , and (b) summing the weighted incomes.

The last step in the meaning representation process involves the computation of  $A$ . In words,  $A$  may be expressed as *far more than the combined income of Naomi's close friends over the past few years*. The expression for  $A$  is yielded by the following procedure.

1. Compute the total income of each  $Name$ , (other than

Naomi) during the past few years:

$$TIName_j = \sum_i \mu_i IName_{ji} \quad (2.5)$$

where  $IName_{ji}$  is the income of  $Name_j$  in  $Year_i$ .

2. Find the fuzzy set of close friends of Naomi by intensifying the relation  $FRIEND[35]$ :

$$CF = CLOSEFRIEND = {}^2FRIEND. \quad (2.6)$$

which implies that

$$\mu_{CF}(Name_j) = ({}_rFRIEND[Name = Name_j])^2,$$

where the expression

$${}_rFRIEND[Name = Name_j]$$

represents  $(\mu_F Name_j)$ , that is, the grade of membership of  $Name_j$  in the set of Naomi's friends.

3. Compute the combined income of Naomi's close friends:

$$CI = \sum_j \mu_{CF}(Name_j) TIName_j, \quad (2.7)$$

which implies that in computing the combined income, the total income of  $Name_j$  is weighted with the degree to which  $Name_j$  is a close friend of Naomi.

4. The desired expression for  $A$  is obtained by substituting  $CI$  for  $Income2$  in  $FRA. MORE$  and projecting the result on  $Income1$  and  $\mu$ . Thus

$$A = \mu_{Income1} FRA. MORE (Income2 = CI). \quad (2.8)$$

In summary, the meaning of  $p$  may be represented as the possibilistic assignment statement (1.3) in which the constrained variable,  $X$ , is given by (2.4), and the elastic constraint on  $X$  is expressed by (2.8). In essence, the possibilistic assignment statement (1.3) defines the possibility distribution of  $X$  given  $p$ . What this means is that  $A$ , as expressed by (1.8), associates with each numerical value of  $Income1$ , the possibility that it could be

far more than the combined income of Naomi's close friends over the past few years.

The same basic technique may be applied to the representation of the meaning of a wide variety of propositions in a natural language. In the following, we present in a summarized form a few representative examples.

Example 1.

$$p: \text{Richard is blond.} \quad (2.9)$$

In this case

$$p \rightarrow \text{Color}(\text{Hair}(\text{Richard})) \text{ is } \text{BLOND}, \quad (2.10)$$

where  $\rightarrow$  stands for *translates into*.

Example 2.

$$p: \text{Brian is much taller than Mildred.} \quad (2.11)$$

Here  $X$  is a binary variable  $(X_1, X_2)$  whose components are

$$X_1 = \text{Height}(\text{Brian})$$

and

$$X_2 = \text{Height}(\text{Mildred}).$$

The elastic constraint on  $X = (X_1, X_2)$  is characterized by the fuzzy relation *MUCH.TALLER*. Thus,

$$p \rightarrow (\text{Height}(\text{Brian}), \text{Height}(\text{Mildred})) \text{ is } \text{MUCH.TALLER}$$

is the possibilistic assignment statement which represents the meaning of (2.11).

Example 3.

$$p: \text{most Swedes are blond.} \quad (2.12)$$

In this case, the constrained variable  $X$  is the proportion of blond Swedes among the Swedes. More specifically,

$$X = \Sigma \text{Count}(\text{BLOND}/\text{SWEDE}), \quad (2.13)$$

where the right-hand member expresses the *relative sigma-count*



[40] of blond Swedes among the Swedes. Thus, if the individuals in a sample population in Sweden are labeled  $Name_1, \dots, Name_n$ , then

$$\Sigma Count(BLOND/SWEDE) = \frac{\sum_i \mu_{BLOND}(Name_i) \wedge \mu_{SWEDE}(Name_i)}{\sum_i \mu_{SWEDE}(Name_i)} \quad (2.14)$$

in which  $\mu_{BLOND}(Name_i)$  and  $\mu_{SWEDE}(Name_i)$  represent, respectively, the degrees to which  $Name_i, i = 1, \dots, n$ , is blond and swedish, and the conjunctive connective  $\wedge$  yields the minimum of its arguments.

The elastic constraint on  $X$  is characterized by the possibility distribution of the fuzzy quantifier *most*, which is a fuzzy number *MOST*. From (2.13) and (2.14), it follows that the possibilistic assignment statement which represents the meaning of (2.12) may be expressed as

$$p \rightarrow \Sigma Count(BLOND/SWEDE) \text{ is } MOST, \quad (2.15)$$

in which the constrained variable is given by (2.14).

### 3. Inference

One of the important advantages of employing the concept of a generalized assignment statement for purposes of meaning representation is that the process of deductive retrieval from a knowledge base is greatly facilitated when the propositions in the knowledge base are represented as generalized assignment statements. This is a direct consequence of the fact that a generalized assignment statement places in evidence the variable which is constrained and the constraint to which it is subjected.

Viewed in this perspective, a knowledge base may be equated

to a collection of generalized assignment statements, and a query may be interpreted as a question regarding the value of a specified variable. Equivalently, a knowledge base may be regarded as a specification of elastic constraints on a collection of knowledge base variables  $X_1, \dots, X_n$ , the answer to a query as the induced constraint on the variable in the query; and the inference process as the computation of the induced constraint on the query variable as a function of the given constraints on the knowledge base variables. In this view, the inference process resembles this solution of a nonlinear program [42, 44].

In the following, our discussion of the problem of inference will be limited in scope. More specifically, we shall restrict our attention to disjunctive (i. e., possibilistic) assignment statements, since the inference rules for conjunctive statements can readily be derived by dualization, that is, replacing  $\subset$  (is contained in) with  $\supset$  (contains), and  $\cap$  (intersection) with  $\cup$  (union). Furthermore, we shall state only the principal rules of inference and will omit proofs.

In the rules stated below,  $X, Y, Z, \dots$ , are the constrained variables and  $A, B, C, \dots$ , are the constraining possibility distributions.

Entailment principle

$$\frac{X \text{ is } A}{\frac{A \subset B}{X \text{ is } B}} \quad (3.1)$$

Unary conjunctive rule

$$\frac{X \text{ is } A}{\frac{X \text{ is } B}{X \text{ is } A \cap B}} \quad (3.2)$$

In the conclusion,  $A \cap B$  denotes the intersection of  $A$  and  $B$  which is defined by

$$\mu_{A \cap B}(u) = \mu_A(u) \wedge \mu_B(u), u \in U. \quad (3.3)$$

Binary conjunctive rule

$$\frac{\begin{array}{l} X \text{ is } A \\ Y \text{ is } B \end{array}}{(X, Y) \text{ is } A \times B}, \quad (3.4)$$

where  $A \times B$  denotes the cartesian product of  $A$  and  $B$ , defined by

$$\mu_{A \times B}(u, v) = \mu_A(u) \wedge \mu_B(v), u \in U, v \in V, \quad (3.5)$$

where  $U$  and  $V$  are the domains of  $X$  and  $Y$ , respectively.

Cylindrical extension rule

$$\frac{X \text{ is } A}{(X, Y) \text{ is } A \times V}, \quad (3.6)$$

where  $V$  is the domain of  $Y$ .

Projective rule

$$\frac{(X, Y) \text{ is } A}{X \text{ is } {}_X A}, \quad (3.7)$$

where  ${}_X A$  denotes the projection  $A$  on the domain of  $X$ . The membership function of  ${}_X A$  is defined by

$$\mu(u) = \bigvee_v (\mu_A(u, v)), \quad (3.8)$$

where  $\bigvee_v$  denotes the supremum over  $v \in V$ .

Compositional rule

$$\frac{\begin{array}{l} X \text{ is } A \\ (X, Y) \text{ is } B \end{array}}{X \text{ is } A \circ B}, \quad (3.9)$$

where  $A \circ B$  denotes the composition of  $A$  and  $B$ , defined by

$$\mu_{A \circ B}(v) = \bigvee_u (\mu_A(u) \wedge \mu_B(u, v)). \quad (3.10)$$

The compositional rule may be viewed as a corollary of the cylindrical extension rule, the binary conjunctive rule and the

projective rule.

Extension principle

$$\frac{X \text{ is } A}{f(X) \text{ is } f(A)}, \quad (3.11)$$

where  $f$  is a function from  $U$  to  $V$ , and  $f(A)$  is a possibility distribution defined by

$$\mu_{f(A)}(v) = \bigvee_u \mu_A(u), \text{ over all } v \text{ such that } v = f(u). \quad (3.12)$$

A more general version of the extension principle which follows from (3.4) and (3.11) is

$$\frac{\begin{array}{c} X \text{ is } A \\ Y \text{ is } B \end{array}}{f(X, Y) \text{ is } f(A, B)}, \quad (3.13)$$

Generalized modus ponens

$$\frac{\begin{array}{c} X \text{ is } A \\ \text{If } X \text{ is } B \text{ then } Y \text{ is } C \end{array}}{Y \text{ is } A \circ (B' \oplus C)}, \quad (3.14)$$

in which  $B'$  is the complement of  $B$  and  $\oplus$  is the bounded sum, defined by

$$\mu_{B \oplus C}(v) = 1 \vee (1 - \mu_B(v) + \mu_C(v)), \quad (3.15)$$

where  $\vee = \max$ . The inference rule expressed by (3.14) follows from the compositional rule of inference (3.9) and the assumption that the meaning of the conditional assignment statement which is the second premise in (3.14) is expressed by [36].

$$\text{if } X \text{ is } B \text{ then } Y \text{ is } C \rightarrow \pi_{(Y|X)}(u, v) = 1 \vee (1 - \mu_A(u) + \mu_B(v)), \quad (3.16)$$

where  $\pi_{(Y|X)}$  denotes the conditional possibility distribution function of  $Y$  given  $X$ .

## References

- [1] Ballmer, T. T., and Pinkal, M. (eds.), *Approaching Vagueness*. Amsterdam; North-Holland, 1983.
- [2] Bandler, W., Representation and manipulation of knowledge in fuzzy expert systems, *Proc. Workshop on Fuzzy Sets and Knowledge-Based Systems*, Queen Mary College, University of London, 1983.
- [3] Bartsch, R. and Vennenmann, T., *Semantic Structures*. Frankfurt: Attenaum Verlag, 1972.
- [4] Barwise, J. and Cooper, R., Generalized quantifiers and natural language, *Linguistics and Philosophy* 4(1981) 159~219.
- [5] Bonissone, P. P., A survey of uncertainty representation in expert systems, in *Proc. Second Workshop of the North-American Fuzzy Information Processing Society*, General Electric Corporate Research and Development, Schenectady, NY, 1983.
- [6] Bosch, P., Vagueness, ambiguity and all the rest, in: *Sprachstruktur, Individuum und Gessellschaft*, Van de Velde, M., and Vandeweghe, W. (eds.), Tübingen: Niemeyer, 1978.
- [7] Brachman, R.J. What is a is and isn't, *Computer* 16(1983).
- [8] Cresswell, M.J., *Logic and Language*. London: Methuen, 1973.
- [9] Czogała, E., *Probabilistic Sets in Decision Making and Control*. Rhineland: Verlag TUV, 1984
- [10] Dubois, D., and Prade, H., Fuzzy cardinality and the modeling of imprecise quantification, *Fuzzy Sets and Systems* 16(1985) 199~230.
- [11] Dubois, D., and Prade, H., *Théorie des Possibilités*, Paris: Masson, 1985.
- [12] Fox, M. S., On inheritance in knowledge representation, *Proc. IJCAI*

(1979) 282~284.

- [13] Giles, R. , Foundations for a theory of possibility, in: *Fuzzy Information and Decision Processes*, Gupta, M. M. and Sanchez, E. (eds. ), Amsterdam: North-Holland, 183~195.
- [14] Goodman, I. R. , and Nguyen, H. T. , *Uncertainty Models for Knowledge-Based Systems*. Amsterdam: North-Holland, 1985.
- [15] Hirota, K. , and Pedrycz, W. , Analysis and synthesis of fuzzy systems by the use of probabilistic sets, *Fuzzy Sets and Systems* 10(1983) 1~13.
- [16] Israel, D. , The role of logic in knowledge representation, *Computer* 16 (1983) 37~41.
- [17] Kamp, H. , A theory of truth and semantic representation, in *Formal Methods in the Study of Language*, Groenendijk, J. A. et al. (eds. ), Mathematical Centre, Amsterdam, Tract 135, 1981.
- [18] Kandel, A. , *Fuzzy Mathematical Techniques with Applications*. Reading: Addison-Wesley, 1986.
- [19] Kaufmann, A. and Gupta, M. , *Introduction to Fuzzy Arithmetic*. New York: Van Nostrand, 1985.
- [20] Keenan, E. , (ed. ). *Formal Semantics of Natural Language*. Cambridge: Cambridge University Press, 1975.
- [21] Lambert, K. , and van Fraassen, B. C. , Meaning relations, possible objects and possible worlds, *Philosophical Problems in Logic* (1970) 1~19
- [22] Mamdani, E. H. , and Gaines, B. R. , *Fuzzy Reasoning and its Applications*. London: Academic Press, 1981.
- [23] McDermott, D. , and Cherniak, E. , *Introduction to Artificial Intelligence*. Reading: Addison-Wesley, 1985.
- [24] Moore, R. C. , *Problems in Logical Form*, SRI Tech. Report 241, Menlo Park, 1981.
- [25] Moore, R. C. , The role of logic in knowledge representation and commonsense reasoning, *Proc. AAAI*(1982)428~433.

- [26] Nilsson, N. , *Principles of Artificial Intelligence*, Palo Alto: Tioga Press, 1980.
- [27] Ralescu, D. , Toward a general theory of fuzzy variables, *Journ. Math. Analysis and Appl.* 86(1982)176~193.
- [28] Rich, C. , Knowledge representation languages and predicate calculus: how to save your cake and eat it too, *Proc. AAAI(1982)*192~196.
- [29] Scheffler, I. , *A Philosophical Inquiry into Ambiguity, Vagueness and Metaphor in Language*. London: Routledge & Kegan Paul, 1981.
- [30] Tarski, A. , *Logic, Semantics, Metamathematics*. Oxford: Clarendon Press, 1956.
- [31] van Fraassen, B. C. , *Formal Semantics and Logic*. New York: Macmillan, 1971.
- [32] Wahlster, W. , Hahn, W. V. , Hoepfner, W. , and Jameson, A. , The anatomy of the natural language dialog system HAM-RPM, in: *Natural Language Computer Systems*, Bolc, L. , (ed. ). Amsterdam: North-Holland, 205~233, 1976.
- [33] Yager, R. , Reasoning with fuzzy quantified statements- 1 , *Kybernetes* 14(1985)233~240.
- [34] Yager, R. , *Set Based Representation of Conjunctive and Disjunctive Knowledge* Machine Intelligence Institute Tech. Rep. M11-604, Iona College, New Rochelle NY, 1986.
- [35] Zadeh, L. A. , A fuzzy-set-theoretic interpretation of linguistic hedges, *Journal of Cybernetics* 2(1972)4~34.
- [36] Zadeh, L. A. , PRUF—a meaning representation language for natural language, *Int J. Man-Machine Studies* 10(1978) 395~460.
- [37] Zadeh, L. A. , Fuzzy sets and information granularity, in *Advances in Fuzzy Set Theory and Applications* (Gupta, M. , Ragade, R. and Yager, R. , eds. ). Amsterdam North-Holland, 3~18, 1979.
- [38] Zadeh, L. A. , Test-score semantics for natural languages and meaning-representation via PRUF, *Tech. Note 247, AI Center, SRI International, Menlo Park, CA*, 1981. Also in: *Empirical Semantics*,

- Rieger, B. B. , (ed. ). Bochum: Brockmeyer, 281~349,1981.
- [39] Zadeh, L. A. , Possibility theory as a basis for meaning representation, in: *Proc. of the Sixth Wittgenstein Symposium*, Leinfellner, W. , et al, (eds. ), Kirchberg,253~261,1982
- [40] Zadeh, L. A. , A Computational Approach to Fuzzy Quantifiers in Natural Languages. *Computers and Mathematics* 9(1983) 149~184.
- [41] Zadeh, L. A. , A fuzzy-set-theoretic approach to the compositionality of meaning; Propositions, dispositions and canonical forms, *Journal of Semantics* 3 (1983) 253~272.
- [42] Zadeh, L. A. , The role of fuzzy logic in the management of uncertainty in expert systems, *Fuzzy Sets and Systems* 11 (1983) 199~227.
- [43] Zadeh, L. A. , Syllogistic reasoning in fuzzy logic and its application to usuality and reasoning with dispositions, *IEEE Transactions on Systems, Man and Cybernetic SMC-15* (1985) 754~763.
- [44] Zimmermann, J. , *Fuzzy Set Theory-and its Applications*. Boston: Kluwer, 1985.



Part 5: Soft  
computing with words

.



# **Fuzzy Logic=Computing with Words**

## **1. Introduction**

Fuzzy logic has come of age. Its foundations have become firmer, its applications have grown in number and variety, and its influence within the basic sciences—especially in mathematical and physical sciences—has become more visible and more substantive. Yet, there are two questions that are still frequently raised: a) what is fuzzy logic and b) what can be done with fuzzy logic that cannot be done equally well with other methodologies, e. g., predicate logic, probability theory, neural network theory, Bayesian networks, and classical control?

The title of this note is intended to suggest a succinct answer; the main contribution of fuzzy logic is a methodology for computing with words. No other methodology serves this purpose. What follows is an elaboration on this suggestion. A fuller exposition of the methodology of computing with words (CW) will appear in a forthcoming paper.

Needless to say, there is more to fuzzy logic than a methodology for CW. Thus, strictly speaking, the equality in the title of this note should be an inclusion; using the equality serves to accentuate the importance of computing with words as a branch of fuzzy logic.

## 2. What is CW?

In its traditional sense, computing involves (for the most part) manipulation of numbers and symbols. By contrast, humans employ mostly words in computing and reasoning, arriving at conclusions expressed as words from premises expressed in a natural language or having the form of mental perceptions. As used by humans, words have fuzzy denotations. The same applies to the role played by words in CW.

The concept of CW is rooted in several papers starting with [39] in which the concepts of a linguistic variable and granulation were introduced. The concepts of a fuzzy constraint and fuzzy constraint propagation were introduced in [32], and developed more fully in [35] and [37]. Application of fuzzy logic to meaning representation and its role in test-score semantics are discussed in [33] and [36].

Although the foundations of computing with words were laid some time ago, its evolution into a distinct methodology in its own right reflects many advances in our understanding of fuzzy logic and soft computing—advances which took place within the past few years. A key aspect of CW is that it involves a fusion of natural languages and computation with fuzzy variables. It is this fusion that is likely to result in an evolution of CW into a basic methodology in its own right, with wide-ranging ramifications and applications.

We begin our exposition of CW with a few definitions. It should be understood that the definitions are dispositional; that is, they do not apply in some cases.

The point of departure in CW is the concept of a granule. In essence, a granule is a fuzzy set of points having the form of a clump of elements drawn together by similarity. A word  $w$  is a label of a granule  $g$  and, conversely,  $g$  is the denotation of  $w$ . A word may be atomic (as in *young*) or composite (as in *not very young*). Unless stated to the contrary, a word will be assumed to be composite. The denotation of a word may be a higher order predicate, as in Montague grammar [23].

In CW, a granule  $g$  which is the denotation of a word  $w$  is viewed as a fuzzy constraint on a variable. A pivotal role in CW is played by fuzzy constraint propagation from premises to conclusions. It should be noted that as a basic technique, constraint propagation plays important roles in many methodologies, especially in mathematical programming, constraint programming, and logic programming.

As a simple illustration, consider the proposition *Mary is young*. In this case, *young* is the label of a granule *young* (note that for simplicity, the same symbol is used both for a word and its denotation). The fuzzy set *young* plays the role of a fuzzy constraint on the age of Mary.

As a further example, consider the propositions

$$p_1 = \text{Carol lives near Mary}$$

and

$$p_2 = \text{Mary lives near Pat.}$$

In this case, the words "lives near" in  $p_1$  and  $p_2$  play the role of fuzzy constraints on the distances between the residences of Carol and Mary and Mary and Pat, respectively. If the query is, "How far is Carol from Pat?," an answer yielded by fuzzy

constraint propagation might be expressed as  $p_3$ , where

$$p_3 = \text{Carol lives not far from Pat.}$$

More about fuzzy constraint propagation will be discussed at a later point.

A basic assumption in CW is that information is conveyed by constraining the values of variables. Furthermore, information is assumed to consist of a collection of propositions expressed in a natural or synthetic language.

A basic generic problem in CW is the following.

We are given a collection of propositions expressed in a natural language which constitute the initial data set (IDS).

From the IDS we wish to infer an answer to a query expressed in a natural language. The answer, also expressed in a natural language, is referred to as the terminal data set (TDS). The problem is to derive TDS from IDS.

A few problems will serve to illustrate these concepts. At this juncture, the problems will be formulated but not solved.

1) Assume that a function  $f, f: U \rightarrow V, X \in U, Y \in V$  is described in words by the fuzzy IF-THEN rules

$f$ : if  $X$  is small then  $Y$  is small  
if  $X$  is medium then  $Y$  is large  
if  $X$  is large then  $Y$  is small.

What this implies is that  $f$  is approximated to by the fuzzy graph  $f^*$  (Fig. 1), where

$$f^* = \text{small} \times \text{small} + \text{medium} \times \text{large} \\ + \text{large} \times \text{small}.$$

In  $f^*$ ,  $+$ , and  $\times$  denote, respectively, the disjunction and Cartesian product. An expression of the form  $A \times B$ , where  $A$  and

$B$  are words, will be referred to as a *cartesian granule*. In this sense, a fuzzy graph may be viewed as a disjunction of cartesian granules. In essence, a fuzzy graph serves as an approximation to a function or a relation [31],[38].

In the example under consideration, the IDS consists of the fuzzy-rule set  $f$ . The query is, "What is the maximum value of  $f$ " (Fig. 2)?" More broadly, the problem is, "How can one compute an attribute of a function  $f$ , e. g. ,its maximum value or its area or its roots, if  $f$  is described in words as a collection of fuzzy IF-THEN rules?"

2) A box contains ten balls of various sizes of which several are large and a few are small. What is the probability that a ball drawn at random is neither large nor small? In this case, the IDS is a verbal description of the contents of the box, the TDS is the desired probability.

3) A less simple example of computing with words is the following: let  $X$  and  $Y$  be independent random variables taking values in a finite set  $V = \{v_1, \dots, v_n\}$  with probabilities  $p_1, \dots, p_n$  and  $q_1, \dots, q_n$ , respectively. For simplicity of notation, the same symbols will be used to denote  $X$  and  $Y$  and their generic values, with  $p$  and  $q$  denoting the probabilities of  $X$  and  $Y$ , respectively. Assume that the probability distributions of  $X$  and  $Y$  are described in words through the fuzzy IF-THEN rules

$P$ : if  $X$  is small then  $p$  is small  
if  $X$  is medium then  $p$  is large  
if  $X$  is large then  $p$  is small

and

$Q$ : if  $Y$  is small then  $q$  is large

if  $Y$  is medium then  $q$  is small

if  $Y$  is large then  $q$  is large

where the granules small, medium, and large are the values of the linguistic variables  $X$  and  $Y$  in their respective universe of discourse. In the example under consideration, these rule sets constitute the IDS. Note that small in  $P$  need not have the same meaning as small in  $Q$ , and likewise for medium and large.

The query is, "How can we describe, in words, the joint probability distribution of  $X$  and  $Y$ ?" This probability distribution is the TDS.

For convenience, the probability distributions of  $X$  and  $Y$  may be represented as fuzzy graphs

$$P: \text{small} \times \text{small} + \text{medium} \times \text{large} + \text{large} \times \text{small}$$

$$Q: \text{small} \times \text{large} + \text{medium} \times \text{large} + \text{large} \times \text{large}$$

with the understanding that the underlying numerical probabilities must add up to unity.

Since  $X$  and  $Y$  are independent random variables, their joint probability distribution  $(P, Q)$  is the product of  $P$  and  $Q$ . In other words, the product may be expressed as [38]

$$\begin{aligned} (P, Q): & \text{small} \times \text{small} \times (\text{small} * \text{large}) + \text{small} \\ & \times \text{medium} \times (\text{small} * \text{small}) + \text{small} \times \text{large} \\ & \times (\text{small} * \text{large}) + \dots + \text{large} \times \text{large} \\ & \times (\text{small} * \text{large}) \end{aligned}$$

where  $*$  is the arithmetic product in fuzzy arithmetic [14], [19]. In effect, what we have done in this example amounts to a derivation of a linguistic characterization of the joint probability distribution of  $X$  and  $Y$ , starting with linguistic characterizations of the probability distribution of  $X$  and the probability



distribution of  $Y$ .

A few comments are in order. In linguistic characterizations

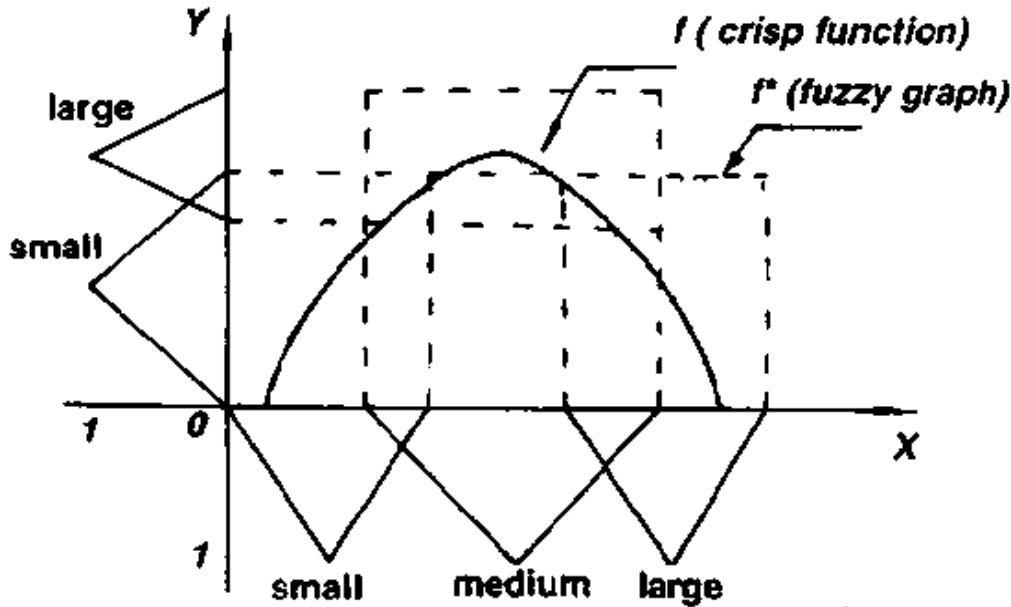

Fig. 1.  $f^*$  is a fuzzy graph which approximates a function  $f$ .

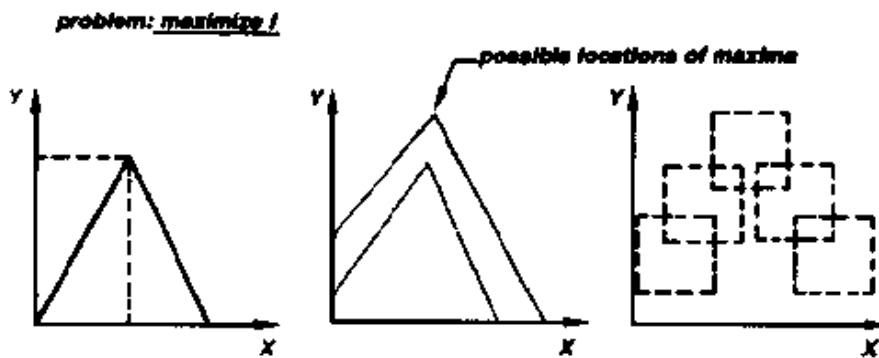

Fig. 2. Maximization of a crisp function, an interval-valued function, and a fuzzy graph.

of variables and their dependencies, words serve as the values of variables and play the role of fuzzy constraints. In this perspective, the use of words may be viewed as a form of granulation, which in turn may be regarded as a form of fuzzy

quantization.

Granulation plays a key role in human cognition. For humans, it serves as a way of achieving data compression. This is one of the pivotal advantages accruing through the use of words in human, machine, and man-machine communication.

In the final analysis, the rationale for computing with words rests on two major imperatives. First, computing with words is a necessity when the available information is too imprecise to justify the use of numbers, and second, when there is a tolerance for imprecision which can be exploited to achieve tractability, robustness, low solution cost, and better rapport with reality.

The conceptual structure of computing with words is schematized in Fig. 3(a) and (b). Basically, CW may be viewed as a confluence of two related streams; fuzzy logic and test-score semantics, with the latter based on fuzzy logic. The point of contact is the collection of canonical forms of the premises, which are assumed to be propositions expressed in a natural language (NL). The function of canonical forms is to explicitate the implicit fuzzy constraints which are resident in the premises. With canonical forms as the point of departure, fuzzy constraint propagation leads to conclusions in the form of induced fuzzy constraints. Finally, the induced constraints are translated into NL through the use of linguistic approximation [30], [18].

In computing with words, there are two core issues that arise. First is the issue of representation of fuzzy constraints. More specifically, the question is, "How can the fuzzy constraints which are implicit in propositions (expressed in a natural language) be made explicit." Second is the issue of fuzzy

constraint propagation; that is, the question of how can fuzzy constraints in premises be propagated to conclusions. These are the issues which are addressed in the following section.

### 3. Representation of fuzzy constraints and canonical forms

Our approach to the representation of fuzzy constraints is based on test-score semantics [33], [36]. In outline, in this semantics, a proposition  $p$  in a natural language is viewed as a network of fuzzy (elastic) constraints. Upon aggregation, the constraints which are embodied in  $p$  result in an overall fuzzy constraint which can be represented as an expression of the form

$$X \text{ is } R$$

where  $R$  is a constraining fuzzy relation and  $X$  is the constrained variable. The expression in question is called a *canonical form*. The function of a canonical form is to place in evidence the fuzzy constraint which is implicit in  $p$ . This is represented schematically as

$$p \rightarrow X \text{ is } R$$

in which the arrow  $\rightarrow$  denotes explicitation. The variable  $X$  may be vector-valued and/or conditioned.

In this perspective, the meaning of  $p$  is defined by two procedures. The first procedure acts on a so-called explanatory database (ED) and returns the constrained variable  $X$ . The second procedure acts on ED and returns the constraining relation  $R$ .

An ED is a collection of relations in terms of which the meaning of  $p$  is defined. The relations are empty; that is, they consist of relation names, relations attributes, and attribute

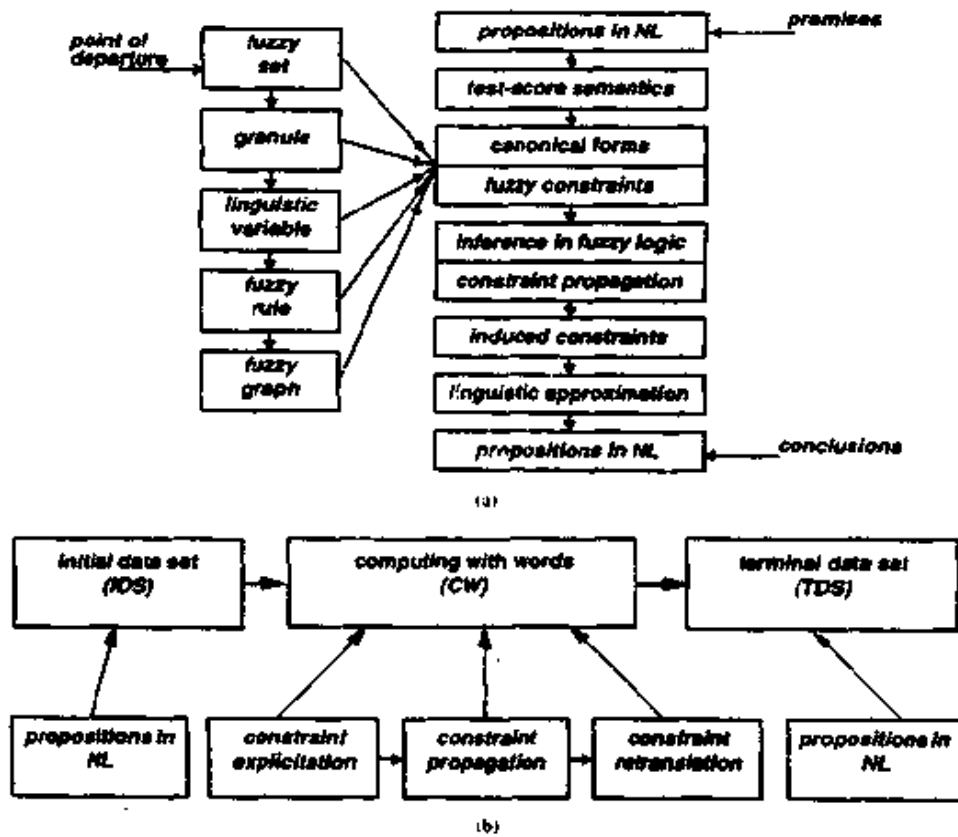

Fig. 3. (a) Conceptual structure of CW and (b) a more detailed version.

domains, with no entries in the relations. When there are entries in ED, ED is said to be *instantiated* and is denoted EDI. EDI may be viewed as a description of a possible world in possible world semantics [6], with ED defines a collection of possible worlds, with each possible world in the collection corresponding to a particular instantiation of ED.

As a simple illustration, consider the proposition

$$p = \text{Mary is not young.}$$

Assume that the explanatory database is chosen to be

$$ED = \text{POPULATION}[\text{Name}; \text{Age}] + \text{YOUNG}[\text{Age}; \mu]$$

in which POPULATION is a relation with arguments Name and

Age, YOUNG is a relation with arguments Age and  $\mu$ , and + is the disjunction. In this case, the constrained variable is the age of Mary which, in terms of ED, may be expressed as

$$X = \text{Age}(\text{Mary}) =_{\text{Age}} \text{POPULATION}[\text{Name} = \text{Mary}].$$

This expression specifies the procedure which acts on ED and returns  $X$ . More specifically, in this procedure, Name is instantiated to Mary and the resulting relation is projected on Age, yielding the age of Mary.

The constraining relation  $R$  is given by

$$R = ({}^2\text{YOUNG})'$$

which implies that the intensifier *very* is interpreted as a squaring operation, and the negation *not* as the operation of complementation.

Equivalently,  $R$  may be expressed as

$$R = \text{YOUNG}[\text{Age}; 1 - \mu^2].$$

As a further example, consider the proposition

$$p = \text{Carol lives in a small city near San Francisco}$$

and assume that the explanatory database is

$$\begin{aligned} \text{ED} = & \text{POPULATION}[\text{Name}; \text{Residence}] \\ & + \text{SMALL}[\text{City}; \mu] \\ & + \text{NEAR}[\text{City 1}; \text{City 2}; \mu]. \end{aligned}$$

In this case

$$\begin{aligned} X = & \text{Residence}(\text{Carol}) \\ = &_{\text{Residence}} \text{POPULATION}[\text{Name} = \text{Carol}] \end{aligned}$$

and

$$R = \text{SMALL}[\text{City}; \mu] \cap_{\text{City 1}} \text{NEAR}[\text{City 2} = \text{San Francisco}].$$

In  $R$ , the first constituent is the fuzzy set of small cities, the second constituent is the fuzzy set of cities which are near San

Francisco, and  $\cap$  denotes the intersection of these sets. So far, we have confined our attention to constraints of the form

$$X \text{ is } R.$$

In fact, constraints can have a variety of forms. In particular, a constraint — expressed as a canonical form — can be conditional; that is, of the form

$$\text{if } X \text{ is } R \text{ then } Y \text{ is } S$$

which may also be written as

$$Y \text{ is } S \text{ if } X \text{ is } R.$$

The constraints in question will be referred to as *basic*.

For purposes of meaning representation, the richness of natural languages necessitates a wide variety of constraints in relation to which the basic constraints form an important, though special class. The so-called generalized constraints [37] contain the basic constraints as a special case and are defined as follows.

A generalized constraint is represented as

$$X \text{ isr } R$$

where *isr* (pronounced “ezar”) is a variable copula which defines the way in which *R* constrains *X*. More specifically, the role of *R* in relation to *X* is defined by the value of the discrete variable *r*. The values of *r* and their interpretations are defined below:

e; equal (abbreviated to =)

d; disjunctive (possibilistic) (abbreviated to blank)

c; conjunctive

p; probabilistic

$\lambda$ ; probability value

u; usuality

rs; random set

rsf: random fuzzy set  
 fg: fuzzy graph  
 ps: rough set (Pawlak Set)  
 . . .

As an illustration, when  $r=e$ , the constraint is an equality constraint and is abbreviated to  $=$ . When  $r$  takes the value  $d$ , the constraint was *disjunctive* (possibilistic), and "isd" abbreviated to "is" led to the expression

$$X \text{ is } R$$

in which  $R$  is a fuzzy relation which constrains  $X$  by playing the role of the possibility distribution of  $X$ . More specifically, if  $X$  takes values in a universe of discourse,  $U = \{u\}$ , then  $\text{Poss} \{X = u\} = \mu_R(u)$ , where  $\mu_R$  is the membership function of  $R$ , and  $\Pi_X$  is the possibility distribution of  $X$ ; that is, the fuzzy set of its possible values. In schematic form

$$\begin{aligned}
 X \text{ is } R & \quad \Pi_X = R \\
 & \quad \text{Poss} \{X = u\} = \mu_R(u).
 \end{aligned}$$

Similarly, when  $R$  takes the value  $c$ , the constraint is *conjunctive*. In the case

$$X \text{ isc } R$$

means that if the grade of membership of  $u$  in  $R$  is  $\mu$ , then  $X = u$  has truth value  $\mu$ . For example, a canonical form of the proposition

$p = \text{John is proficient in English, French, and German}$   
 may be expressed as

Proficiency (John) isc (1/English + 0.7/French + 0.6/German)  
 in which 1.0, 0.7, and 0.6 represent, respectively, the truth values of the propositions John is proficient in English, John is

proficient in French, and John is proficient in German.

When  $r=p$ , the constraint is *probabilistic*. In this case

$$X \text{ isp } R$$

means that  $R$  is the probability distribution of  $X$ . For example

$$X \text{ isp } N(m, \sigma^2)$$

means that  $X$  is normally distributed with mean  $m$  and variance  $\sigma^2$ . Similarly

$$X \text{ isp } (0.2 \setminus a + 0.5 \setminus b + 0.3 \setminus c)$$

means that  $X$  is a random variable which takes the values,  $a$ ,  $b$ , and  $c$  with respective probabilities 0.2, 0.5, and 0.3.

The constraint

$$X \text{ isu } R$$

is an abbreviation for

$$\text{usually } (X \text{ is } R)$$

which in turn means that

$$\text{Prob } \{X \text{ is } R\} \text{ is usually.}$$

In this expression,  $X \text{ is } R$  is a fuzzy event and *usually* is its fuzzy probability; that is, the possibility distribution of its crisp probability.

The constraint

$$X \text{ isrs } P$$

is a random set constraint. This constraint is a combination of probabilistic and possibilistic constraints. More specifically, in a schematic form it is expressed as

$$\begin{array}{c} X \text{ isp } P \\ (X, Y) \text{ is } Q \\ \hline Y \text{ isrs } R \end{array}$$

where  $Q$  is a joint possibilistic constraint on  $X$  and  $Y$ , and  $R$  is



a random set. It is of interest to note that the Dempster-Shafer theory of evidence is, in essence, a theory of random set constraints.

In computing with words, the starting point is a collection of propositions which play the role of premises. In most cases, the canonical forms of these propositions are constraints of the basic, disjunctive type. In a more general setting, the constraints are of the generalized type, implying that the explicitation of a proposition  $p$  may be represented as

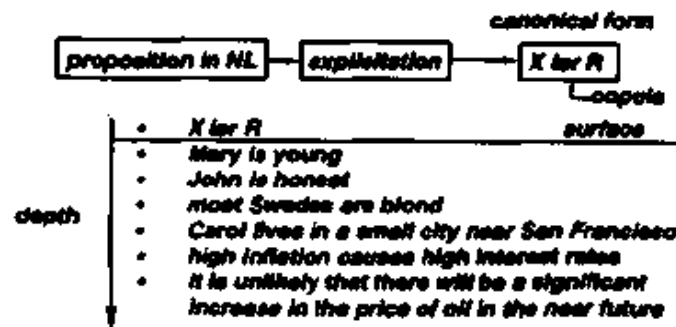

Fig. 4. Depth of explicitation.

$$p \rightarrow X \text{ isr } R$$

where  $X \text{ isr } R$  is the canonical form of  $p$ .

As in the case of basic constraints, the canonical form of a proposition may be derived through the use of test-score semantics. In this context, the depth of  $p$  is roughly a measure of the effort that is needed to explicitate  $p$ , that is, to translate  $p$  into its canonical form. In this sense, the proposition  $X \text{ isr } R$  is a surface constraint (depth = zero), with the depth of explicitation increasing in the downward direction (Fig. 4). Thus, a proposition such as "Mary is young" is shallow, whereas, "it is not very likely that there will be a substantial increase in the

price of oil in the near future" is not.

Once the propositions in the initial data set are expressed in their canonical forms, the ground work is laid for fuzzy constraint propagation. This is a basic part of CW which is discussed in the following section.

#### 4. Fuzzy constraint propagation and the rules of inference in fuzzy logic

The rules governing fuzzy constraint propagation are, in effect, the rules of inference in fuzzy logic. In addition to these rules, it is helpful to have rules governing fuzzy constraint modification. The latter rules will be discussed later in this section.

In a summarized form, the rules governing fuzzy constraint propagation are the following ( $A$  and  $B$  are fuzzy relations. Disjunction and conjunction are defined, respectively, as max and min, with the understanding that more generally, they could be defined via  $t$ -norms and  $s$ -norms [15]).

*Conjunctive Rule 1:*

$$\frac{\begin{array}{l} X \text{ is } A \\ X \text{ is } B \end{array}}{X \text{ is } A \cap B}$$

*Conjunctive Rule 2:* ( $X \in U, Y \in B, A \subset U, B \subset V$ )

$$\frac{\begin{array}{l} X \text{ is } A \\ Y \text{ is } B \end{array}}{(X, Y) \text{ is } A \times B}$$

*Disjunctive Rule 1:*

$$X \text{ is } A$$

or

$$\frac{X \text{ is } B}{X \text{ is } A \cup B}$$

*Disjunctive Rule 2:*  $(A \subset U, B \subset V)$

$$\frac{\begin{array}{c} X \text{ is } A \\ Y \text{ is } B \end{array}}{(X, Y) \text{ is } A \times V \cup U \times B}$$

where  $A \times V$  and  $U \times B$  are cylindrical extensions of  $A$  and  $B$ , respectively.

*Conjunctive Rule for isc:*

$$\frac{\begin{array}{c} X \text{ isc } A \\ X \text{ isc } B \end{array}}{X \text{ isc } A \cup B}$$

*Disjunctive Rule for isc:*

$$X \text{ isc } A$$

or

$$\frac{X \text{ isc } B}{X \text{ isc } A \cap B}$$

*Projective Rule:*

$$\frac{(X, Y) \text{ is } A}{Y \text{ is } \text{proj}_V A}$$

where  $\text{proj}_V A = \sup_u A$ .

*Surjective Rule:*

$$\frac{X \text{ is } A}{(X, Y) \text{ is } A \times V}$$

*A. Derived Rules*

*Compositional Rule:*

$$\frac{\begin{array}{c} X \text{ is } A \\ (X, Y) \text{ is } B \end{array}}{Y \text{ is } A \circ B}$$

where  $A \circ B$  denotes the composition of  $A$  and  $B$ . *Extension*

*Principle (Mapping Rule):*

$$\frac{X \text{ is } A}{f(X) \text{ is } f(A)}$$

where  $f: U \rightarrow V$ , and  $f(A)$  is defined by

$$\mu_{f(A)}(v) = \sup_{u|v=f(u)} \mu_A(u).$$

*Inverse Mapping Rule:*

$$\frac{f(X) \text{ is } A}{X \text{ is } f^{-1}(A)}$$

where  $\mu_{f^{-1}(A)}(u) = \mu_A(f(u))$ .

*Generalized Modus Ponens:*

$$\frac{X \text{ is } A \quad \text{if } X \text{ is } B \text{ then } Y \text{ is } C}{Y \text{ is } A \circ ((\neg B) \oplus C)}$$

where the bounded sum  $\neg B \oplus C$  represents Lukasiewicz's definition of implication.

*Generalized Extension Principle:*

$$\frac{f(X) \text{ is } A}{g(X) \text{ is } g(f^{-1}(A))}$$

where

$$\mu_g(v) = \sup_{u|v=f(u)} \mu_A(g(u)).$$

The generalized extension principle plays a pivotal role in fuzzy constraint propagation.

*Syllogistic Rule [36]:*

$$\frac{Q_1 A \text{ 's are } B \text{ 's} \quad Q_2 (A \text{ and } B) \text{ 's are } C \text{ 's}}{(Q_1 \otimes Q_2) A \text{ 's are } (B \text{ and } C) \text{ 's}}$$

where  $Q_1$  and  $Q_2$  are fuzzy quantifiers;  $A$ ,  $B$ , and  $C$  are fuzzy relations and  $Q_1 \otimes Q_2$  is the product of  $Q_1$  and  $Q_2$  in fuzzy arithmetic.

*Constraint Modification Rules* [29], [34], [35]:

$$X \text{ is } mA \rightarrow X \text{ is } f(A)$$

where  $m$  is a modifier such as *not*, *very*, *more or less*, and  $f(A)$  defines the way in which  $m$  modifies  $A$ . Specifically

if  $m = \textit{not}$  then  $f(A) = A'$  (complement)

if  $m = \textit{very}$  then  $f(A) = {}^2A$  (left square)

where  $\mu_{2A}(u) = (\mu_A(u))^2$ . This rule is a convention and should not be construed as a realistic approximation to the way in which the modifier *very* functions in a natural language.

*Probability Qualification Rule* [34], [35]:

$$(X \text{ is } A) \text{ is } \Lambda \rightarrow P \text{ is } \Lambda$$

where  $X$  is a random variable taking values in  $U$  with probability density  $p(u)$ ,  $\Lambda$  is a linguistic probability expressed in words like *likely*, *not very likely*, etc., and  $P$  is the probability of the fuzzy event  $X$  is  $A$ , expressed as

$$P = \int_U \mu_A(u) p(u) du.$$

The primary purpose of this summary is to underscore the coincidence of the principal rules governing fuzzy constraint propagation with the principal rules of inference in fuzzy logic. Of necessity, the summary is not complete and there are many specialized rules which are not included. Furthermore, most of the rules in the summary apply to constraints which are of the basic, disjunctive type. Further development of the rules governing fuzzy constraint propagation will require an extension of the rules of inference to generalized constraints.

As was alluded to in the summary, the principal rule governing constraint propagation is the generalized extension

principle which in a schematic form may be represented as

$$\frac{f(X_1, \dots, X_n) \text{ is } A}{q(X_1, \dots, X_n) \text{ is } q(f^{-1}(A))}$$

In this expression,  $X_1, \dots, X_n$  are database variables, the term above the line represents the constraint induced by the IDS, and the term below the line is the TDS expressed as a constraint on the query  $q(X_1, \dots, X_n)$ . In the latter constraint,  $f^{-1}(A)$  denotes the preimage of the fuzzy relation  $A$  under the mapping  $f: U \rightarrow V$ , where  $A$  is a fuzzy subset of  $V$  and  $U$  is the domain of  $f(X_1, \dots, X_n)$ .

Expressed in terms of the membership functions of  $A$  and  $q(f^{-1}(A))$ , the generalized extension principle reduces the derivation of the TDS to the solution of the constrained maximization problem

$$u_{q(X_1, \dots, X_n)}(v) = \sup_{(u_1, \dots, u_n)} (\mu_A(f(u_1, \dots, u_n)))$$

in which  $u_1, \dots, u_n$  are constrained by

$$v = q(u_1, \dots, u_n).$$

The generalized extension principle is simpler than it appears. An illustration of its use is provided by the following example:

The IDS is:

*most Swedes are tall*

The query is : *What is the average height of Swedes?*

The explanatory database consists of a population of  $N$  Swedes,  $Name_1, \dots, Name_N$ . The database variables are  $h_1, \dots, h_N$ , where  $h_i$  is the height of  $Name_i$ , and the grade of membership of  $Name_i$  in *tall* is  $\mu_{\text{tall}}(h_i)$ ,  $i=1, \dots, n$ .

The proportion of Swedes who are tall is given by

$$\frac{1}{N} \sum_i \mu_{\text{tall}} (h_i)$$

from which it follows that the constraint on the database variables induced by the IDS is

$$\frac{1}{N} \sum_i \mu_{\text{tall}} (h_i) \text{ is most.}$$

In terms of the database variables  $h_1, \dots, h_N$ , the average height of Swedes is given by

$$h_{\text{ave}} = \frac{1}{N} \sum_i h_i.$$

Since the IDS is a fuzzy proposition,  $h_{\text{ave}}$  is a fuzzy set whose determination reduces to the constrained maximization problem

$$\mu_{h_{\text{ave}}} (v) = \sup_{h_1, \dots, h_N} \left( \mu_{\text{most}} \left( \frac{1}{N} \sum_i \mu_{\text{tall}} (h_i) \right) \right)$$

subject to the constraint

$$v = \frac{1}{N} \sum_i h_i.$$

It is possible that approximate solutions to problems of this type might be obtainable through the use of genetic algorithm-based methods.

A key point, which is brought out by this example and the preceding discussion, is that explicitation and constraint propagation play pivotal roles in CW. What is important to recognize is that there is a great deal of computing with numbers in CW which takes place behind a curtain, unseen by the user. Thus, what matters is that in CW the IDS is allowed to be expressed in a natural language. No other methodology offers this facility. As an illustration of this point, consider the following problem.

A box contains ten balls of various sizes of which several are large and a few are small. What is the probability that a ball drawn at random is neither large nor small?

To be able to answer this question it is necessary to be able to define the meanings of large, small, several large balls, and neither large nor small. This is a problem in semantics which falls outside of probability theory, neurocomputing, and other methodologies.

There are two observations which are in order. First, in using fuzzy constraint propagation rules in computing with words, application of the extension principle generally reduces to the solution of a nonlinear program. What we need—and do not have at present—are approximate methods of solving such programs which are capable of exploiting the tolerance for imprecision. Without such methods, the cost of solutions may be excessive in relation to the imprecision which is intrinsic in the use of words. In this connection, an intriguing possibility is to use genetic algorithm-based methods to arrive at approximate solutions to constrained maximization problems.

Second, given a collection of premises expressed in a natural language, we can, in principle, express them in their canonical forms and thereby explicitate the implicit fuzzy constraints. For this purpose, we have to employ test-score semantics. However, in test-score semantics we do not presently have effective algorithms for the derivation of canonical forms without human intervention. This is a problem that remains to be addressed.



## 5. Conclusion

The main purpose of this note is to draw attention to the centrality of the role of fuzzy logic in computing with words and vice-versa. In coming years, computing with words is likely to emerge as a major field in its own right. In a reversal of long-standing attitudes, the use of words in place of numbers is destined to gain respectability. This is certain to happen because it is becoming abundantly clear that in dealing with real-world problems there is much to be gained by exploiting the tolerance for imprecision. In the final analysis, it is the exploitation of the tolerance for imprecision that is the prime motivation for CW. The role model for CW is the human mind.

## References

- [1] H. R. Berenji, "Fuzzy reinforcement learning and dynamic programming," in *Fuzzy Logic Artificial Intell. Proc. IJCAI'93 Workshop*, A. L. Ralescu, Ed. Berlin: Springer-Verlag, 1994, pp. 1~9.
- [2] M. Black, "Reasoning with loose concepts," *Dialog*, vol. 2, pp. 1~12, 1963.
- [3] P. Bosch, "Vagueness, ambiguity and all the rest," in *Sprachstruktur, Individuum und Gessellschaft*, M. Van de Velde and W. Vandeweghe, Eds. Tubingen, Germany: Niemeyer, 1978.
- [4] J. Bowen, R. Lai, and D. Bahler, "Fuzzy semantics and fuzzy constraint networks," in *Proc. 1st IEEE Conf. Fuzzy Syst.*, San Francisco, CA, 1992, pp. 1009~1016.
- [5] \_\_\_\_, "Lexical imprecision in fuzzy constraint networks," in *Proc. Natl. Conf. Artificial Intell.*, San Jose, CA, 1992, pp. 616~620.

- [6] M. J. Cresswell, *Logic and Languages*. London: Methuen, 1973.
- [7] D. Dubois, H. Fargier, and H. Prade, "Propagation and satisfaction of flexible constraints," in *Fuzzy Sets, Neural Networks, and Soft Computing*, R. R. Yager and L. A. Zadeh, Eds. New York: Van Nostrand Reinhold, pp. 166~187, 1994.
- [8] \_\_\_\_, "Possibility theory in constraint satisfaction problems: Handling priority, preference, and uncertainty," *Appl. Intell. J.*, to be published.
- [9] \_\_\_\_, "The calculus of fuzzy restrictions as a basis for flexible constraint satisfaction," in *Proc. 2nd IEEE Int. Conf. Fuzzy Syst.*, San Francisco, CA, 1993, pp. 1131~1136.
- [10] E. C. Freuder and P. Snow, "Improved relaxation and search methods for approximate constraint satisfaction with a maximum criterion," in *Proc. 8th Biennial Conf. Canadian Soc. Computat. Stud. Intell.*, Ontario, Canada, 1990, pp. 227~230.
- [11] J. A. Goguen, "The logic of inexact concepts," *Synthese*, vol. 19, pp. 325~373, 1969.
- [12] J. R. Hobbs, "Making computational sense of Montague's intensional logic," *Artificial Intell.*, vol. 9, pp. 287~306, 1978.
- [13] O. Katai, S. Matsubara, H. Masuichi, and M. Ida, "Synergetic computation for constraint satisfaction problems involving continuous and fuzzy variables by using occam," in *Transput. /Occam. Proc. 4th Transput. /Occam Int. Conf.*, S. Noguchi and H. Umeo, Eds. Amsterdam: IOS Press, 1992, pp. 146~160.
- [14] A. Kaufmann and M. M. Gupta, *Introduction to Fuzzy Arithmetic: Theory and Applications*. New York: Van Nostrand, 1985.
- [15] G. Klir and B. Yuan, *Fuzzy Sets and Fuzzy Logic*. Englewood Cliffs, NJ: Prentice-Hall, 1995.
- [16] K. Lano, "A constraint-based fuzzy inference system," in *EPIA 91, Portug. Conf. Artificial Intell.*, P. Barahona, L. M. Pereira, and A. Porto, Eds. Berlin: Springer-Verlag, pp. 45~59, 1991.
- [17] W. A. Lodwick, "Analysis of structure in fuzzy linear programs," *Fuzzy*

- Sets Syst.*, vol. 38, no. 1, pp. 15~26, 1990.
- [18] E. H. Mamdani and B. R. Gaines, Eds., *Fuzzy Reasoning and its Applications*. London: Academic, 1981.
- [19] M. Mares, *Computation Over Fuzzy Quantities*. Boca Raton, FL: CRC, 1994.
- [20] V. Novak, "Fuzzy logic, fuzzy sets, and natural languages," *Int. J. General Syst.*, vol. 20, no. 1, pp. 83~97, 1991.
- [21] V. Novak, M. Ramik, M. Cerny, and J. Nekola, Eds., *Fuzzy Approach to Reasoning and Decision-Making*. Boston: Kluwer, 1992.
- [22] M. S. Oshan, O. M. Saad, and A. G. Hassan, "On the solution of fuzzy multiobjective integer linear programming problems with a parametric study," *Adv. Model. Anal. A*, vol. 24, no. 2, pp. 49~64, 1995.
- [23] B. Partee, *Montague Grammar*. New York: Academic, 1976.
- [24] G. Qi and G. Friedrich, "Extending constraint satisfaction problem solving in structural design," in *Indust. Eng. Applicat. Artificial Intell. Expert Syst.*, 5th Int. Conf., IEA/AIE'92, F. Belli and F. J. Radermacher, Eds. Berlin: Springer-Verlag, 1992, pp. 341~350.
- [25] A. Rosenfeld, R. A. Hummel, and S. W. Zucker, "Scene labeling by relaxation operations," *IEEE Trans. Syst. Man, Cybern.*, vol. 6, pp. 420~433, 1976.
- [26] M. Sakawa, K. Sawada, and M. Inuiguchi, "A fuzzy satisfying method for large-scale linear programming problems with block angular structure," *Eur. J. Operat. Res.*, vol. 81, no. 2, pp. 399~409, 1995.
- [27] S. C. Tong, "Interval number and fuzzy number linear programming," *Adv. Model. Anal. A*, vol. 20, no. 2, pp. 51~56, 1994.
- [28] R. R. Yager, "Some extensions of constraint propagation of label sets," *Int. J. Approx. Reasoning*, vol. 3, pp. 417~435, 1989.
- [29] L. A. Zadeh, "A fuzzy-set theoretic interpretation of linguistic hedges," *J. Cybern.*, vol. 2, pp. 4~34, 1972.

- [30] \_\_\_\_, "Outline of a new approach to the analysis of complex system and decision processes," *IEEE Trans. Syst. Man, Cybern.*, vol. SMC-3, pp. 28~44, 1973.
- [31] \_\_\_\_, "On the analysis of large scale systems," *Systems Approaches and Environment problems*, H. Gottinger, Ed. Gottingen, Germany: Vandenhoeck and Ruprecht, 1974, pp. 23~37.
- [32] \_\_\_\_, "Calculus of fuzzy restrictions," in *Fuzzy Sets and Their Applications to Cognitive and Decision Processes*, L. A. Zadeh, K. S. Fu, M. Shimura, Eds. New York: Academic, 1975, pp. 1~39.
- [33] \_\_\_\_, "PRUF-A meaning representation language for natural languages," *Int. J. Man-Mach. Studies*, vol. 10, pp. 395~460, 1978.
- [34] \_\_\_\_, "Fuzzy sets and information granularity," in *Advances in Fuzzy Set Theory and Applications*, M. Gupta, R. Ragade and R. Yager, Eds. Amsterdam: North-Holland, 1979, pp. 3~18.
- [35] \_\_\_\_, "A theory of approximate reasoning," *Machine Intelligence 9*, J. Hayes, D. Michie, and L. I. Mukulich, Eds. New York: Halstead, 1979, pp. 149~194.
- [36] \_\_\_\_, "Test-score semantics for natural languages and meaning representation via PRUF," *Empirical Semantics*, B. Rieger, Ed. W. Germany: Brockmeyer, 1981, pp. 281~349.
- [37] \_\_\_\_, "Outline of a computational approach to meaning and knowledge representation based on a concept of a generalized assignment statement," in *Proc. Int. Seminar Artificial Intell. Man-Mach. Syst.*, M. Thoma and A. Wyner, Eds. Heidelberg: Springer-Verlag, 1986, pp. 198~211.
- [38] \_\_\_\_, "Fuzzy logic, neural networks and soft computing," *Commun. ACM*, vol. 37, no. 3, pp. 77~84, 1994.
- [39] \_\_\_\_, "Outline of a new approach to the analysis of complex systems and decision processes," *IEEE Trans. Syst., Man, Cybern.*, vol. 3, pp. 28~44, 1973.

# **Toward a Theory of Fuzzy Information Granulation and Its Centrality in Human Reasoning and Fuzzy Logic**

## **1. Preamble**

As the papers in this issue make amply clear, during the past decade fuzzy logic has evolved into a well-structured system of concepts and techniques with a solid mathematical foundation and a widening array of applications ranging from basic sciences to engineering systems, social systems, biomedical systems and consumer products.

And yet there is a basic issue in fuzzy logic that has not been highlighted to the extent that it should. The issue is the centrality of the role of fuzzy information granulation — a mode of granulation which underlies the concepts of linguistic variable, fuzzy if — then rule and fuzzy graph. Clearly, the machinery of fuzzy information granulation has played and is continuing to play a pivotal role in the applications of fuzzy logic. But what is beginning to crystallize is a basic theory of fuzzy information granulation (TFIG) which casts fuzzy logic in a new light and, in time, may come to be recognized as its quintessence. This is the perception that I should like to articulate in this paper.

My perception may be viewed as an evolution of ideas rooted in my 1965 paper on fuzzy sets [24]; 1971 paper on fuzzy systems

[26]; 1973~1976 papers on linguistic variables, fuzzy if-then rules and fuzzy graphs [27~30]; 1979 paper on fuzzy sets and information granularity [31]; 1986 paper on generalized constraints [32] and 1996 paper on computing with words [37]. Furthermore, it reflects many important contributions by others both to the foundations of fuzzy logic and its applications. Among my papers, the 1973 paper in which the basic concepts of linguistic variable and fuzzy if-then were introduced may be viewed as a turning point at which the foundation of TFIG was laid.

In what follows, what I will have to say should be viewed as a summary rather than a full exposition. A more detailed account of the theory of fuzzy information granulation is in the process of gestation.

## 2. Introduction

Among the basic concepts which underlie human cognition there are three that stand out in importance. The three are: granulation, organization and causation. In a broad sense, granulation involves decomposition of whole into parts; organization involves integration of parts into whole; and causation relates to association of causes with effects (Fig. 1).

Informally, granulation of an object  $A$  results in a collection of granules of  $A$ , with a granule being a clump of objects (or points) which are drawn together by indistinguishability, similarity, proximity or functionality (Fig. 2). In this sense, the granules of a human body are the head, neck, arms, chest, etc. In turn, the granules of a head are the forehead, cheeks, nose,

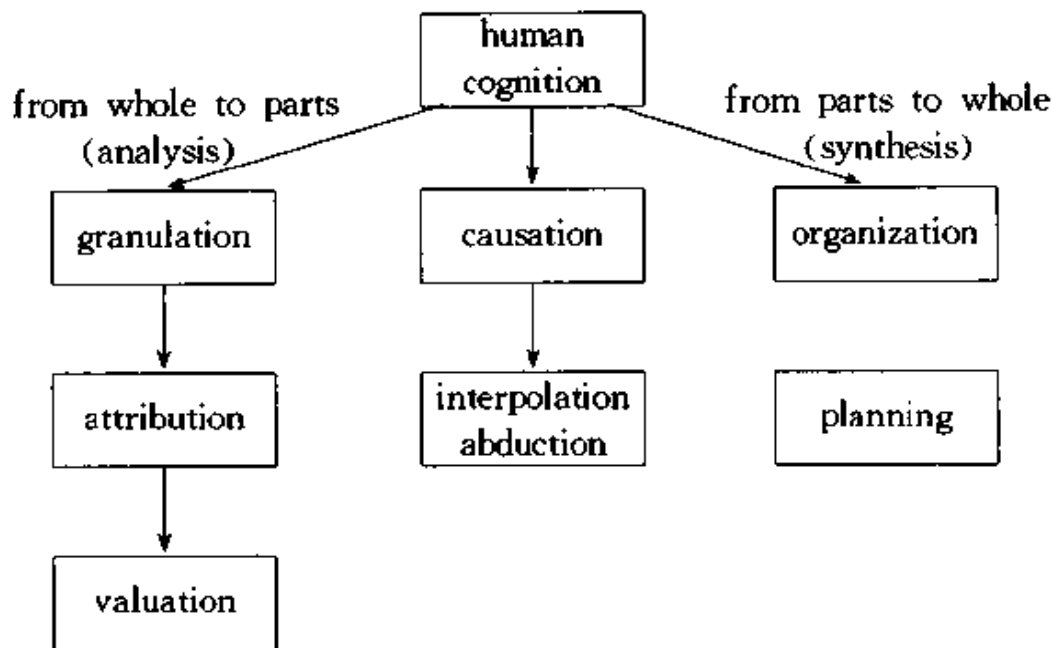

Fig. 1. Fundamental concepts in human cognition: granulation, organization and causation.

ears, eyes, hair, etc. In general, granulation is hierarchical in nature. A familiar example is granulation of time into years, years in months, months into days and so on.

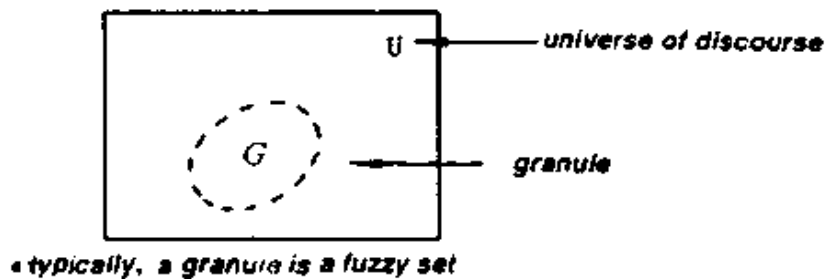

Fig. 2. A granule is a clump of objects (or points) which are drawn together by indistinguishability, similarity, proximity or functionality.

Modes of information granulation (IG) in which the granules are crisp (c-granular) play important roles in a wide variety of methods, approaches and techniques. Among them are: interval

analysis, quantization, rough set theory, diakoptics, divide and conquer, Dempster – Shafer theory, machine learning from examples, chunking, qualitative process theory, decision trees, semantic networks, analog-to-digital conversion, constraint programming, Prolog, cluster analysis and many others.

Important though it is, crisp information granulation (crisp IG) has a major blind spot. More specifically, it fails to reflect the fact that in much, perhaps most, of human reasoning and concept formation the granules are fuzzy (f-granular) rather than crisp. In the case of a human body, for example, the granules are fuzzy in the sense that the boundaries of the head, neck, arms, legs, etc. are not sharply defined. Furthermore, the granules are associated with fuzzy attributes, e. g., length, color and texture in the case of hair. In turn, granule attributes have fuzzy values, e. g., in the case of the fuzzy attribute length (hair), the fuzzy values might be long, short, very long, etc. The fuzziness of granules, their attributes and their values is characteristic of the ways in which human concepts are formed, organized and manipulated (Fig. 3).

A point that is worthy of note is that attributes may be associated with two or more granules, in which case they might be referred to as *intergranular* attributes. An example of an intergranular attribute is the distance between ears, with the understanding that ears are f-granules of head.

In human cognition, fuzziness of granules is a direct consequence of fuzziness of the concepts of indistinguishability, similarity, proximity and functionality. Furthermore, it is entailed by the finite capacity of the human mind and sensory



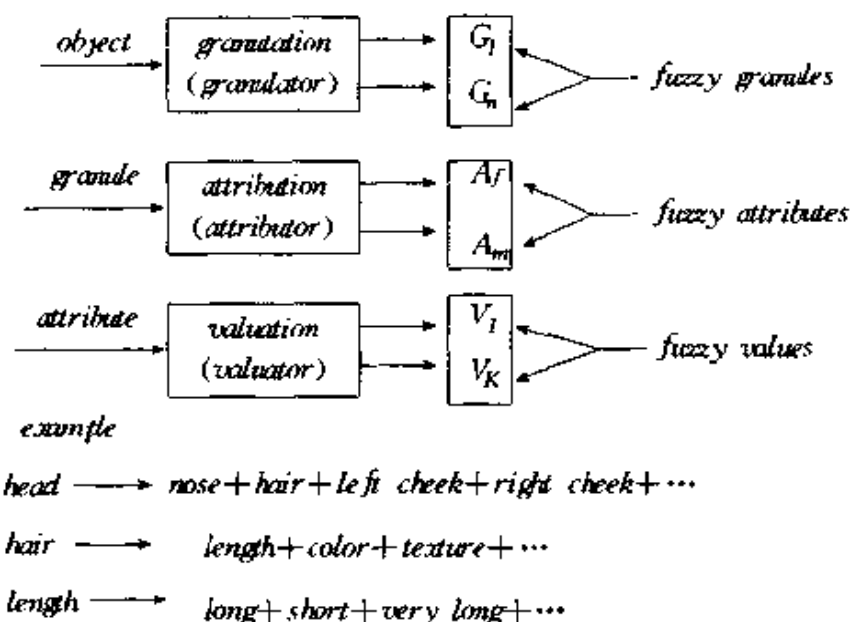

Fig. 3. Basic structure of fuzzy information granulations: granulation, attribution and valuation.

organs to resolve detail and store information. In this perspective, fuzzy information granulation (fuzzy IG) may be viewed as a form of lossy data compression.

Fuzzy information granulation underlies the remarkable human ability to make rational decisions in an environment of imprecision, partial knowledge, partial certainty and partial truth. And yet, despite its intrinsic importance, fuzzy information granulation has received scant attention except in the domain of fuzzy logic, in which, as was pointed already, fuzzy IG underlies the basic concepts of linguistic variable, fuzzy if-then rule and fuzzy graph. In fact, the effectiveness and successes of fuzzy logic in dealing with real-world problems rest in large measure on the use of the machinery of fuzzy information granulation. This machinery is unique to fuzzy logic and differentiates it from all other methodologies. In this connection,

what should be underscored is that when we talk about fuzzy information granulation we are not talking about a single fuzzy granule; we are talking about a collection of fuzzy granules which result from granulating a crisp or fuzzy object.

The theory of fuzzy information granulation (TFIG) outlined in this paper builds on the existing machinery of fuzzy IG in fuzzy logic but goes far beyond it. Basically, TFIG draws its inspiration from the informal ways in which humans employ fuzzy information granulation but its foundation and methodology are mathematical in nature.

In this perspective, fuzzy information granulation may be viewed as a mode of generalization which may be applied to any concept, method or theory. Related to fuzzy IG are the following principal modes of generalization.

(a) Fuzzification (f-generalization). In this mode of generalization, a crisp set is replaced by a fuzzy set (Fig. 4).

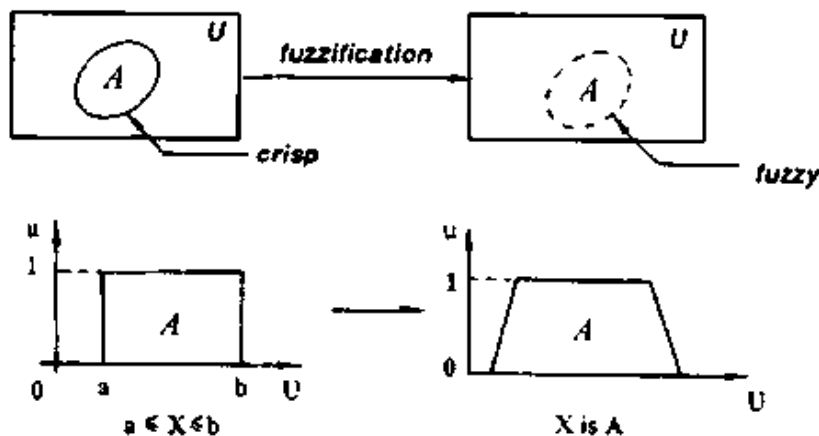

Fig. 4. Fuzzification: crisp set  $\rightarrow$  fuzzy set.

(b) Granulation (g-generalization). In this case, a set is

partitioned into granules (Fig. 5).

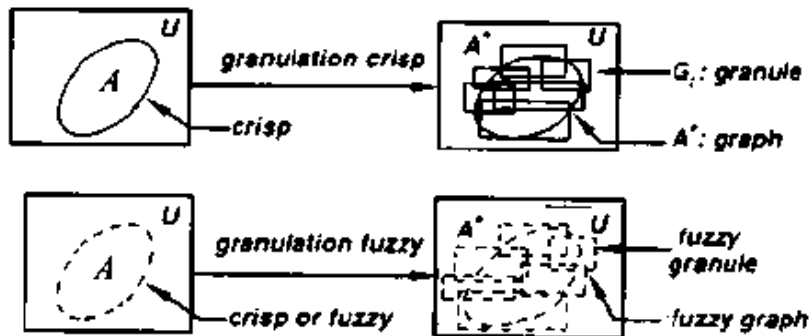

Fig. 5. Granulation. Crisp granulation: crisp set is partitioned into crisp granules. Fuzzy granulation: crisp or fuzzy set is partitioned into fuzzy granules.

- (c) Randomization (r-generalization). In this case, a variable is replaced by a random variable.
- (d) Usualization (u-generalization). In this case, a proposition expressed as  $X \text{ is } A$  is replaced with usually ( $X \text{ is } A$ ).

These and other modes of generalization may be employed in combination. A combination that is of particular importance is the conjunction of fuzzification and granulation. This combination plays a pivotal role in the theory of fuzzy information granulation and fuzzy logic, and will be referred to as f. g-generalization (or f-granulation or fuzzy granulation).

As a mode of generalization, f. g-generalization may be applied to any concept, method or theory. In particular, in application to the basic concepts of variable, function and relation, f. g-generalization leads, in fuzzy logic, to the basic concepts of linguistic variable, fuzzy rule set and fuzzy graph (Fig. 6). These concepts are unique to fuzzy logic and play a

central role in its applications.

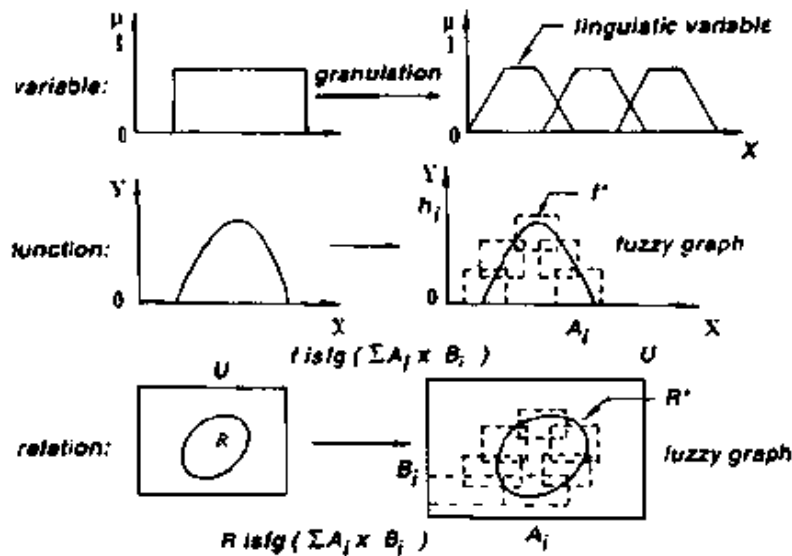

Fig. 6. Granulation of the basic mathematical concepts of variable function and relation. Linguistic variable = f-granular variable. A fuzzy graph may be represented as a fuzzy rule set and vice versa.  $R \text{ isfg } T$  means that  $R$  is constrained by the fuzzy graph  $T$ .

The distinctive concepts of f-generalization, g-generalization, r-generalization and f.g-generalization make a significant contribution to a better understanding of fuzzy logic and its relation to other methodologies for dealing with uncertainty and imprecision. In particular, crisp g-generalization of set theory and relational models of data lead to rough set theory [18]. F-generalization of classical logic and set theory leads to multiple-valued logic, fuzzy logic in its narrow sense and parts of fuzzy set theory (Fig. 7). But it is f.g-generalization that leads to fuzzy logic (FL) in its wide sense and underlies most of its applications. This is a key point that is frequently overlooked in discussions about fuzzy logic and its relation to other

methodologies.

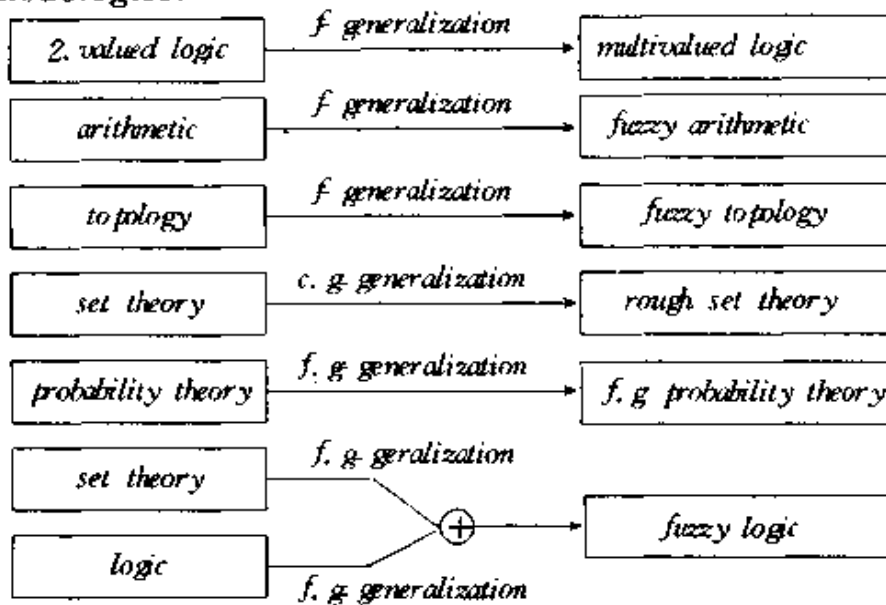

Fig. 7. Theories resulting from applying various modes of generalization.

The theory of fuzzy information granulation serves to highlight the centrality of the concept of fuzzy information granulation in fuzzy logic. More importantly, the theory provides a basis for computing with words (CW) [37]. In effect, CW is an integral part of TFIG. However, since it is discussed elsewhere [37], it will suffice in this paper to summarize its essential features.

The point of departure in CW is the observation that in a natural language words play the role of labels of fuzzy granules. In computing with words, a proposition is viewed as an implicit fuzzy constraint on an implicit variable. The meaning of a proposition is the constraint which it represents.

In CW, the initial data set (IDS) is assumed to consist of a collection of propositions expressed in a natural language. The result of computation, referred to as the terminal data set

(TDS), is likewise a collection of propositions expressed in a natural language. To infer TDS from IDS the rules of inference in fuzzy logic are used for constraint propagation from premises to conclusions (Fig. 8).

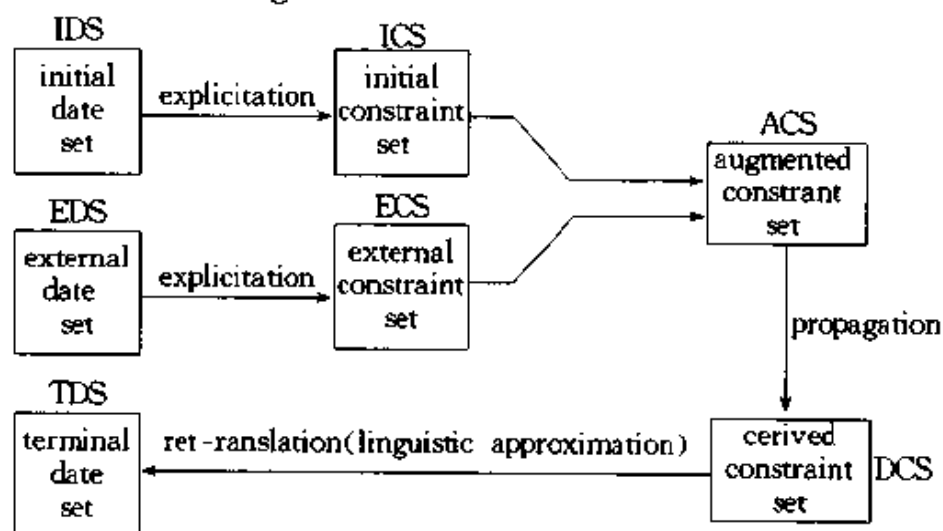

IDS=collection of propositions expressed in a natural language(NL)  
 TDS=collection of propositions expressed in a natural language  
 explicitation=translation from a natural language into the  
 language of generalized constraints(LGC)  
 propagation=constraint propagation through the use of the  
 rules of inference in fuzzy logic

Fig. 8. Basic structure of computing with words(CW).

There are two main rationales for computing with words. First, computing with words is a necessity when the available information is not precise enough to justify the use of numbers. And second, computing with words is advantageous when there is a tolerance for imprecision, uncertainty and partial truth that can be exploited to achieve tractability, robustness, low solution cost and better rapport with reality. In coming years, computing with words is likely to evolve into an important methodology in its own right with wide-ranging applications on both basic and

applied levels.

Inspired by the ways in which humans granulate human concepts, we can proceed to granulate conceptual structures in various fields of science. In a sense, this is what motivates computing with words. An intriguing possibility is to granulate the conceptual structure of mathematics. This would lead to what may be called granular mathematics. Eventually, granular mathematics may evolve into a distinct branch of mathematics having close links to the real world. A subset of granular mathematics and a superset of computing with words is granular computing.

In the final analysis, fuzzy information granulation is central to fuzzy logic because it is central to human reasoning and concept formation. It is this aspect of fuzzy IG that underlies its essential role in the conception and design of intelligent systems. In this regard, what is conclusive is that there are many, many tasks which humans can perform with ease and that no machine could perform without the use of fuzzy information granulation.

A typical example is the problem of estimation of age from voice. More specifically, consider a common situation where  $A$  gets a telephone call from  $B$ , whom  $A$  does not know. After hearing  $B$  talk for 5~10 seconds,  $A$  would be able to form a rough estimate of  $B$ 's age and express it as, say, " $B$  is old" or "*It is very likely that  $B$  is old*", in which both age and probability play the role of linguistic, that is,  $f$ -granulated variables. Neither  $A$  nor any machine could come up with crisp estimates of  $B$ 's age, e. g., " $B$  is 63" or "*The probability that  $B$  is 63 is 0.002*". In this and similar cases, a machine would have to have

a capability to process and reason with f-granulated information in order to come up with a machine solution to a problem that has a human solution expressed in terms of f-granulated variables.

A related point is that, in everyday decision making, humans use that and only that information which is decision-relevant. For example, in playing golf, parking a car, picking up an object, etc., humans use fuzzy estimates of distance, velocity, angles, sizes, etc. In a pervasive way, decision-relevant information is f-granular. To perform such everyday tasks as effortlessly as humans can, a machine must have a capability to process f-granular information. A conclusion which emerges from these examples is that fuzzy information granulation is an integral part of human cognition. This conclusion has a thought-provoking implication for AI: Without the methodology of fuzzy IG in its armamentarium, AI cannot achieve its goals.

In what follows, we shall elaborate on the points made above and describe in greater detail the basic ideas underlying fuzzy information granulation and its role in fuzzy logic.

### **3. The concept of a generalized constraint**

The point of departure in the theory of fuzzy information granulation is the concept of a generalized constraint [32]. For simplicity, we shall restrict our discussion to constraints which are unconditional.

Let  $X$  be a variable which takes values in a universe of discourse  $U$ . A generalized constraint on the values of  $X$  is



expressed as  $X \text{ is } r R$ , where  $R$  is the constraining relation,  $\text{is } r$  is a variable copula and  $r$  is a discrete variable whose value defines the way in which  $R$  constrains  $X$ .

The principal types of constraints and the values of  $r$  which define them are the following:

1. *Equality constraint*,  $r=e$ . In this case,  $X \text{ is } e a$  means that  $X=a$ .

2. *Possibilistic constraint*,  $r=\text{blank}$ . In this case, if  $R$  is a fuzzy set with membership function  $\mu_R: U \rightarrow [0, 1]$ , and  $X$  is a disjunctive (possibilistic) variable, that is, a variable which cannot be assigned two or more values in  $U$  simultaneously, then

$$X \text{ is } R$$

means that  $R$  is the possibility distribution of  $X$ . More specifically,

$$X \text{ is } R \rightarrow \text{Poss} \{X=u\} = \mu_R(u), u \in U.$$

A simple example of a possibilistic constraint is  $X \text{ is } \textit{small}$ . In this case,  $\text{Poss} \{X=u\} = \mu_{\textit{small}}(u)$ . Constraints induced by propositions expressed in a natural language are for the most part possibilistic in nature. This is the reason why the simplest value,  $r=\text{blank}$ , is chosen to define possibilistic constraints.

3. *Veristic constraint*,  $r=v$ . In this case, if  $R$  is a fuzzy set with membership function  $\mu_R$  and  $X$  is a conjunctive (veristic) variable, that is, a variable which can be assigned two or more values in  $U$  simultaneously, then  $X \text{ is } v R \rightarrow \text{Ver} \{X=u\} = \mu_R(u)$ ,  $u \in U$ , where  $\text{Ver} \{X=u\}$  is the verity (truth value) of  $X=u$ .

An example of a veristic constraint is the following. Let  $U$  be the universe of natural languages and let  $X$  denote the fluency

of an individual in English, French and German. Then,  $X$  isv (1.0 English + 0.8 French + 0.6 Italian) means that the degrees of fluency of  $X$  in English, French and Italian are 1.0, 0.8 and 0.6, respectively.

It is important to observe that, in the case of a possibilistic constraint, the fuzzy set  $R$  plays the role of a possibility distribution, whereas in the case of a veristic constraint  $R$  plays the role of a verity distribution. What this implies is that, in general, any fuzzy, and ipso facto any crisp, set  $R$  admits of two different interpretations. <sup>①</sup> More specifically, in the possibilistic interpretation the grades of membership are possibilities, while

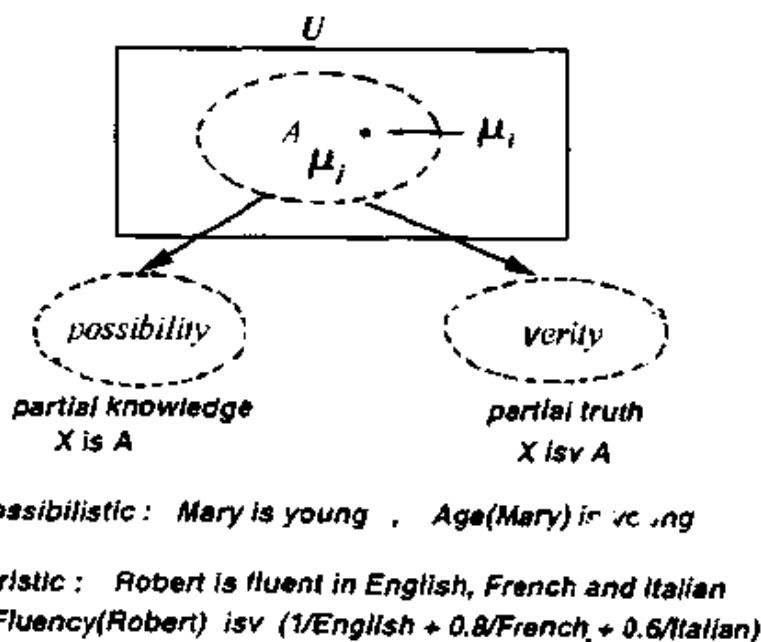

Fig. 9. Possibilistic and veristic interpretations of a fuzzy set.

<sup>①</sup> An insightful discussion of various possible interpretations of grades of membership in a fuzzy set is contained in the paper by D. Dubois and H. Prade, "The Semantics of Fuzzy Sets," in this issue.

in the veristic interpretation the grades of membership are verities (truth values) (Fig. 9.) Since in most cases constraints are possibilistic, the default assumption is that a fuzzy set plays the role of a possibility distribution.

4. *Probabilistic constraint,  $r=p$ .* In this case,  $X \text{ is } p R$  means that  $X$  is a random variable and  $R$  is the probability distribution (or density) of  $X$ . For example,  $X \text{ is } p N(m, \sigma^2)$  means that  $X$  is a normally distributed random variable with mean  $m$  and variance  $\sigma^2$ . Similarly,  $X \text{ is } p (0.2 \setminus a + 0.4 \setminus b + 0.4 \setminus c)$  means that  $X$  takes the values  $a, b, c$  with respective probabilities 0.2, 0.4 and 0.4.

5. *Probability value constraint,  $r=\lambda$ .* In this case,  $X \text{ is } \lambda R$  signifies that what is constrained is the probability of a specified event,  $X \text{ is } A$ . More specifically,  $X \text{ is } \lambda R \rightarrow \text{Prob} \{X \text{ is } A\} \text{ is } R$ . For example, if  $A = \text{small}$  and  $R = \text{likely}$ , then  $X \text{ is } \lambda \text{ likely}$  means that  $\text{Prob} \{X \text{ is small}\} \text{ is likely}$ .

6. *Random set constraint,  $r=rs$ .* In this case,  $X \text{ is } rs R$  is a composite constraint which is a combination of probabilistic and possibilistic (or veristic) constraints. In a schematic form, a random set constraint may be represented as

$$\frac{Y \text{ is } p P}{(X, Y) \text{ is } Q} \\ X \text{ is } rs R$$

or

$$\frac{Y \text{ is } p P}{(X, Y) \text{ is } v Q} \\ X \text{ is } rs R,$$

where  $Q$  is a joint possibilistic (or veristic) constraint on  $X$  and

$Y$ , and  $R$  is a random set, that is, a set-valued random variable. It is of interest to note that the Dempster-Shafer theory of evidence is in essence a theory of random set constraints.

7. *Fuzzy graph constraint,  $r = fg$ .* In this case, in  $X \text{ isfg } R$ ,  $X$  is a function and  $R$  is a fuzzy graph approximation to  $X$  (See Section 5). More specifically, if  $X$  is a function,  $X:U \rightarrow V$ , defined by a fuzzy rule set

*if  $u$  is  $A_1$ , then  $v$  is  $B_1$*

*if  $u$  is  $A_2$ , then  $v$  is  $B_2$*

...

*if  $u$  is  $A_n$ , then  $v$  is  $B_n$*

where  $A_i$  and  $B_i$  are linguistic values of  $u$  and  $v$ , then  $R$  is the fuzzy graph [26, 28~30, 36],

$$R = A_1 \times B_1 + \dots + A_n \times B_n$$

where  $A_i \times B_i$ ,  $i=1, \dots, n$ , is the cartesian product of  $A_i$  and  $B_i$  and  $+$  represents disjunction or, more generally, an  $s$ -norm (Fig. 10).

A fuzzy graph constraint may be represented as a possibilistic constraint on the function which is approximated (Fig. 11). Thus,  $X \text{ isfg } R \rightarrow X \text{ is } (\sum_i A_i \times B_i)$ .

In addition to the types of constraints defined above there are many others that are more specialized and less common. A question that arises is: What purpose is served by having a large variety of constraints to choose from.

A basic reason is that, in a general setting, information may be viewed as a constraint on a variable. For example, the proposition "Mary is young", conveys information about Mary's age by constraining the values that the variable Age (Mary) can

take. Similarly, the proposition "Most Swedes are tall" may be

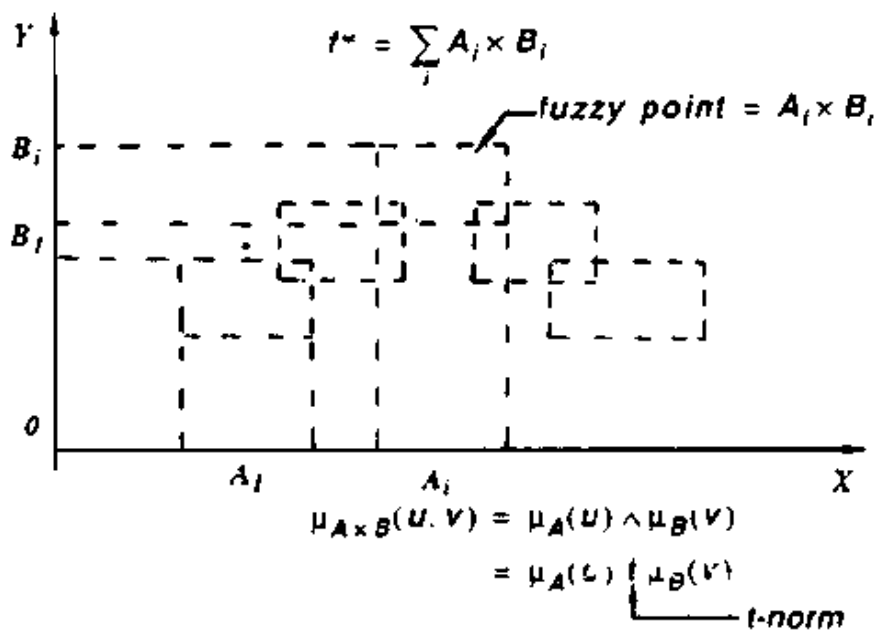

Fig. 10. A fuzzy graph  $f^*$  is a disjunction of cartesian products.

**$X$  isfg  $R$**   
 $X$  = name of a function  
 $R$  = fuzzy graph  
 = disjunction of Cartesian products



$f$  isfg (small x small + medium x large + large x small) →  
 $f$  is (small x small + medium x large + large x small)

• a fuzzy graph is a coarse representation of a function or a relation or a set

Fig. 11. Representation of a fuzzy graph constraint as a possibilistic constraint.

interpreted as a possibilistic constraint on the proportion of tall Swedes, that is,

*most Swedes are tall*

→ *Proportion (tall Swedes/Swedes) is most*

in which the fuzzy quantifier *most* plays the role of a fuzzy number.

More generally, in the context of computing with words, a basic assumption is that a proposition,  $p$ , expressed in a natural language may be interpreted as a generalized constraint  $p \rightarrow X \text{ is } R$ . In this interpretation,  $X \text{ is } R$  is the *canonical form* of  $p$ . The function of the canonical form is to place in evidence, i. e., explicitate, the implicit constraint which  $p$  represents.

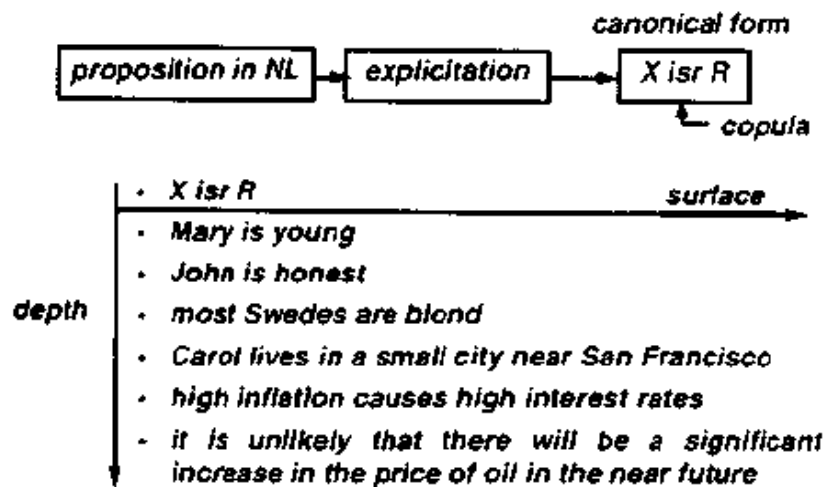

Fig. 12. Depth of explicitation of propositions in a natural language.

In CW [37], the depth of explicitation of a proposition is a measure of the effort involved in explicitating  $p$ , that is, translating,  $p$  into its canonical form. In this sense, the proposition  $X \text{ is } R$  is a surface constraint (depth = zero). As

shown in Fig.12, the depth of explication increases in the downward direction. Thus, a proposition such as "Mary is young" is shallow, whereas "it is not very likely that there will be a significant increase in the price of oil in the near future" is not.

What we see, then, is that the information conveyed by a proposition expressed in a natural language is, in general, too complex to admit of representation as a simple, crisp constraint. This is the main reason why in representing the meaning of a proposition expressed in a natural language we need a wide variety of constraints which are subsumed under the rubric of generalized constraints.

#### 4. Taxonomy of fuzzy granulation

The concept of generalized constraint provides a basis for a classification of fuzzy granules. More specifically, in the theory of fuzzy IG a granule,  $G$ , is viewed as a clump of points characterized by a generalized constraint. Thus,

$$G = \{X | X \text{ is } R\}.$$

In this context, the type of a granule is determined by the type of constraint which defines it (Fig.13). In particular, possibilistic, veristic and probabilistic granules are defined, respectively, by possibilistic, veristic and probabilistic constraints. To illustrate, the granule

$$G = \{X | X \text{ is small}\}$$

is a possibilistic granule. The granule

$$G = \{X | X \text{ isv small}\}$$

is a veristic granule. And the granule

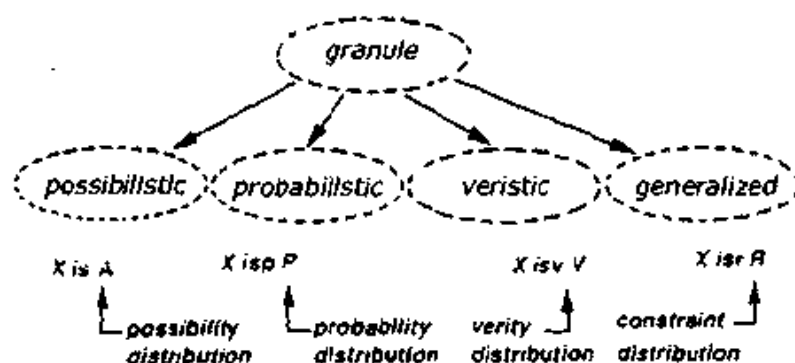

Fig. 13. Taxonomy of granulation.

$$G = \{X | X \text{ is } p \ N(m, \sigma^2)\}$$

is a probabilistic (Gaussian) granule.

As a more concrete illustration consider the fuzzy granule *Nose* of a human head. If we associate with each point on the nose its grade of membership in *Nose*, the fuzzy granule *Nose* should be interpreted as a veristic granule. Now suppose that we associate with the attribute length (*Nose*) a fuzzy value *long*. The question is: What is the meaning of the proposition "Nose is long?"

Assume that the profile of *Nose*, *N*, has the form shown in Fig. 14. With each point *p* on the profile are associated two numbers:  $\alpha$ , representing the grade of membership of *p* in *Nose*; and  $\beta$ , the degree of relevance of *p* to the value of the attribute length (*Nose*). In general,  $\beta \leq \alpha$ .

Now let  $\bar{N}$  be a veristic fuzzy set which results from a rectification of the profile of *Nose* (Fig. 14). At this point, the original question reduces to "What is the length of  $\bar{N}$ ?" This question is a familiar one in fuzzy logic. Assume for simplicity that the set is trapezoidal, as shown in Fig. 15. Then, by using



the  $\alpha$ -cuts of  $\bar{N}$ , its length may be represented as a veristic triangular fuzzy set  $L(\bar{N})$  (Fig. 15). Thus,  $L(\bar{N})$  is the answer to the original question. However, if a single real value of the length of nose it required,  $L(\bar{N})$  may be defuzzified using, say, the COG definition of defuzzification.

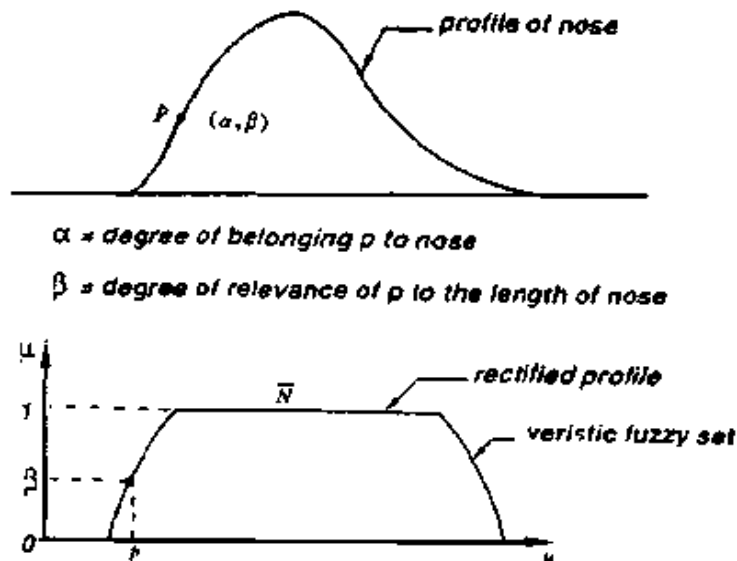

Fig. 14. Profile of *Nose* and its rectification.

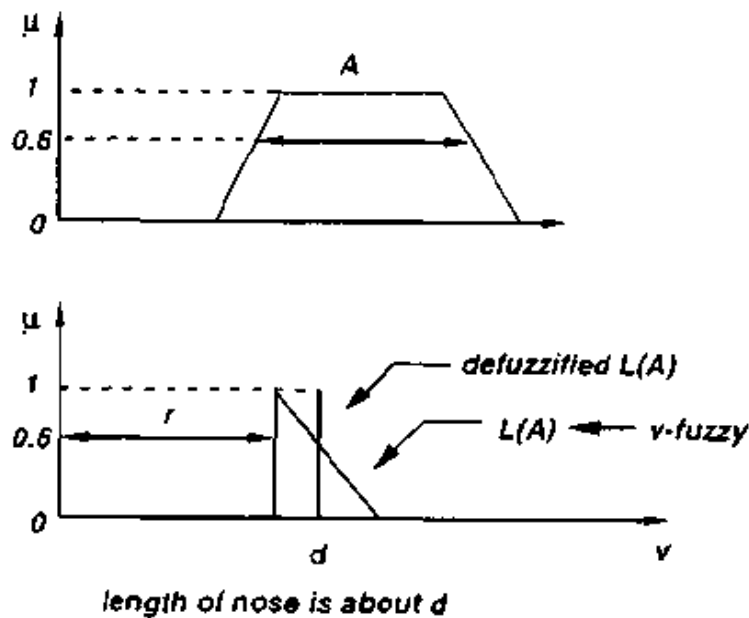

Fig. 15. Length of a trapezoidal fuzzy set and length of *Nose*.

The purpose of this simple example is to show how a fuzzy value may be associated with a fuzzy attribute of a fuzzy granule. A more complex example would be an association of a fuzzy value *long* with the fuzzy attribute (*Hair*). In this case, the problem is very similar to that of associating a fuzzy value with the fuzzy attribute *unemployment* for a fuzzy segment of a population in a city, region or country.

In the foregoing discussion, classification of granules is based on the types of constraints which define them. A different mode of classification involves representation of complex granules as cartesian products or other combinations of simpler granules.

More specifically, let  $G_1, \dots, G_n$  be granules in  $U_1, \dots, U_n$ , respectively. Then the granule  $G = G_1 \times \dots \times G_n$  is a cartesian granule. For simplicity, we shall assume that  $n=2$  (Fig. 16).

An important elementary property of cartesian granules relates to their  $\alpha$ -cuts. Thus, if  $G = G_1 \times G_2$  and  $G_\alpha, G_{1\alpha}$  and  $G_{2\alpha}$  are  $\alpha$ -cuts of  $G, G_1$  and  $G_2$ , respectively, then

$$G_\alpha = G_{1\alpha} \times G_{2\alpha}.$$

A cartesian granule,  $G$ , may be rotated (Fig. 17). More generally, a cartesian granule,  $G$ , may be subjected to a coordinate transformation defined by

$$\begin{aligned} X &\rightarrow f(X, Y), \\ Y &\rightarrow g(X, Y). \end{aligned}$$

In this case, if  $G_1$  and  $G_2$  are defined by possibly different generalized constraints:

$$\begin{aligned} G_1 &: X \text{ isr } A \\ G_2 &: X \text{ iss } B \end{aligned}$$

a cartesian granule is a non-interactive conjunction  
(cartesian product) of granules

$$G = G_1 \times \dots \times G_n$$

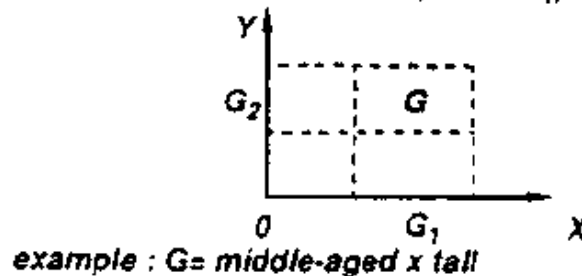

Fig. 16. Cartesian granule.

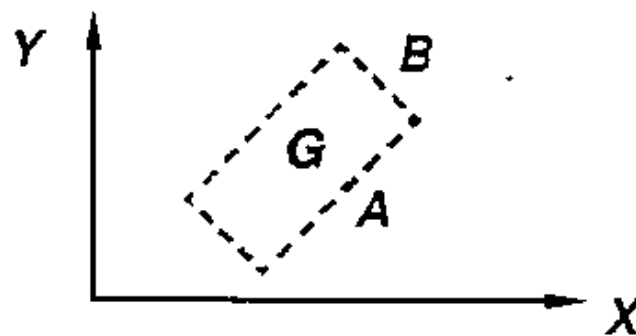

Fig. 17. Rotated cartesian granule.

then the transformed granule  $G^*$  is defined by

$$G^* : (f(X, Y) \text{ is } A) \times (g(X, Y) \text{ is } B).$$

A generalized constraint in which what is constrained is a function or a functional of a variable will be referred to as a *generalized functional constraint* (Fig. 18). Such constraints play an important role in computing with words.

The importance of the concept of a cartesian granule derives in large measure from its role in what might be called *encapsulation*.

More specifically, consider a granule,  $G$ , defined by a possibilistic constraint  $G = \{ (X, Y) \mid (X, Y) \text{ is } R \}$ .

Let  $G_X$  and  $G_Y$  denote the projections of  $G$  on  $U$  and  $V$ , the domains of  $X$  and  $Y$ , respectively. Thus,

$$\mu_{G_X}(u) = \sup_v \mu_G(u, v), \quad u \in U, v \in V$$

$$\mu_{G_Y}(v) = \sup_u \mu_G(u, v).$$

Then, the cartesian granule  $G^+$ ,

$$G^+ = G_X \times G_Y$$

encapsulates  $G$  in the sense that it is the least upper bound of cartesian granules which contain  $G$ . (Fig. 19). Invoking the entailment principle in fuzzy logic allows us to assert that

$$(X, Y) \text{ is } G \Rightarrow (X, Y) \text{ is } G^+.$$

Thus,  $G^+$  can be used as an upper approximation to  $G$  [25]. It should be noted that in the case of veristic constraints the entailment principle asserts that

<p>if <math>F_1(X_1, \dots, X_m)</math> is <math>C_{11}</math> and ... <math>F_n(X_1, \dots, X_m)</math> is <math>C_{1n}</math> then <math>Y_1</math> is <math>D_{11}</math> and ... <math>Y_k</math> is <math>D_{1k}</math></p> <p style="text-align: center;">...</p> <p>if <math>F_{1l}(X_1, \dots, X_m)</math> is <math>C_{1l}</math> and ... <math>F_{ln}(X_1, \dots, X_m)</math> is <math>C_{ln}</math> then <math>Y_1</math> is <math>D_{1l}</math> and ... <math>Y_k</math> is <math>D_{1k}</math></p>
--

- rule explosion
- number of rules depends on the choice of features

Fig. 18. Format of a fuzzy rule set representing a collection of possibilistic functional constraints.

$$(X, Y) \text{ isv } A \Rightarrow (X, Y) \text{ isv } B$$

if  $B \subset A$ .

In a more general setting, we can construct a cylindrical extension of  $G$  in the manner shown in Fig. 20 [25]. More concretely, the cylindrical extension,  $G_\alpha^+$ , of  $G$  in direction  $\alpha$  is a

- any granule  $G$  can be approximated from above by an encapsulating cartesian granule  $G^+$

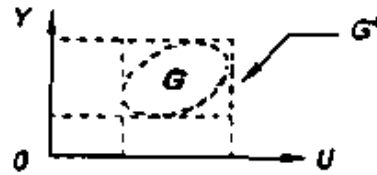

$$G^+ = \text{proj}_U G \times \text{proj}_Y G$$

- entailment principle

$$X \text{ is } G \longrightarrow X \text{ is } G^+$$

Fig. 19. A granule,  $G$ ; its projection and its encapsulating granule,  $G^+$ .



- $R(p; \alpha) =$  line passing through  $p$  in direction  $\alpha$ ,  $\alpha = (\theta_1, \theta_2)$
- $G_\alpha^+ =$  cylindrical extension of  $G$  in direction  $\alpha$
- $\mu_{G_\alpha^+}(p) = \sup (G \cap R(p; \alpha))$
- $G_\alpha^+ =$  smallest cylinder containing  $G$  in direction  $\alpha$

Fig. 20.  $G_\alpha^+$  is a cylindrical extension of  $G$  in direction  $\alpha$ .

cylindrical fuzzy set such that

$$\mu_{G_\alpha^+}(p) = \sup (G \cap R(p; \alpha))$$

where  $R(p; \alpha)$  is a ray (line) passing through  $p$  in direction  $\alpha$ ,  $\alpha = (\theta_1, \theta_2)$ , where  $\theta_1$  and  $\theta_2$  are the angles that define  $\alpha$ . By its construction,  $G_\alpha^+$  encapsulates  $G$ .

Let  $G_{\alpha_1}^+, \dots, G_{\alpha_n}^+$  be cylindrical extensions of  $G$  in directions

$\alpha_1, \dots, \alpha_n$ , respectively. Then, the intersection of the  $G_{\alpha_i}^+$  is a granule,  $G^+$ , that encapsulates  $G$  (Fig. 21). This concept of an encapsulating granule subsumes that of a cartesian encapsulating granule as a special case.

$G^+ =$  cartesian encapsulating granule of  $G$   
 $=$  intersection of cylindrical extensions of  $G$

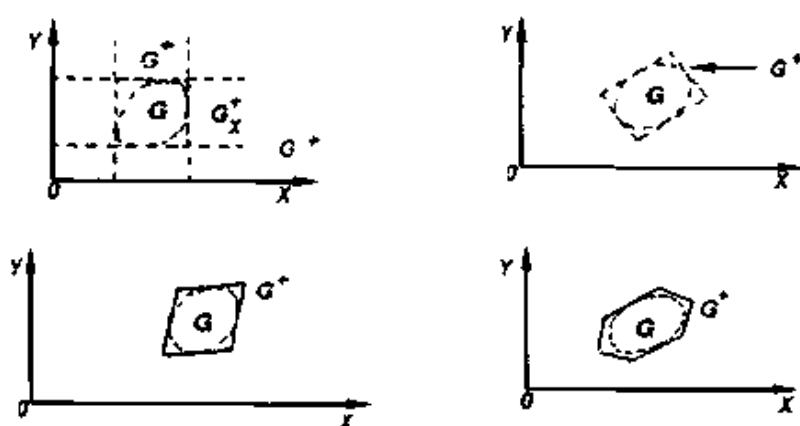

Fig. 21. Encapsulating granules generated by intersections of cylindrical extensions.

As shown in [25], an encapsulating granule  $G^+$  may be viewed as an upper approximation to  $G$ . Dually, as shown in [25], one can define a lower approximation to  $G$ . However, these concepts of upper and lower approximation of fuzzy granules are different from those defined in the theory of rough sets [18].

## 5. Fuzzy graphs

One of the most basic facets of human cognition relates to the perception of dependencies and relations. In the theory of fuzzy information granulation, this facet of human cognition

underlies the very basic concept of a *fuzzy graph*.

The concept of a fuzzy graph was introduced in [26] and was developed more fully in [28~30]. What might be called the *calculus of fuzzy graphs* [36] lies at the center of fuzzy logic and is employed in most of its applications.

In the context of fuzzy information granulation, a fuzzy graph may be viewed as the result of *f. g-generalization* of the concepts of function and relation (Fig. 6).

As the point of departure consider a function (or a relation)  $f$  which is defined by a table of the form

$f$	$X$	$Y$
	$a_1$	$b_1$
	$a_2$	$b_2$
	•	•
	$a_n$	$b_n$

*F. g-generalization* of  $f$  results in a function  $f^*$  whose defining table is of the form

$f^*$	$X$	$Y$
	$A_1$	$B_1$
	$A_2$	$B_2$
	•	•
	$A_n$	$B_n$

(1)

where  $X$  and  $Y$  play the role of linguistic (granular) variables, with the  $A_i$  and  $B_i$ ,  $i = 1, \dots, n$ , representing their linguistic values. The defining table of  $f^*$  may be expressed as the fuzzy rule set

$$f^* : \text{if } X \text{ is } A_1 \text{ then } Y \text{ is } B_1$$

$$\text{if } X \text{ is } A_2 \text{ then } Y \text{ is } B_2 \quad (2)$$

...

$$\text{if } X \text{ is } A_n \text{ then } Y \text{ is } B_n.$$

It is important to note that in this context a fuzzy if-then rule of the form "if  $X$  is  $A$  then  $Y$  is  $B$ " is not a logical implication but a reading of the ordered pair  $(A, B)$ . This point is discussed more fully in [28, 29].

As postulated in [28~30], the meaning of the defining table (1) and, equivalently, the fuzzy rule set (2), is the fuzzy graph (Fig. 22)

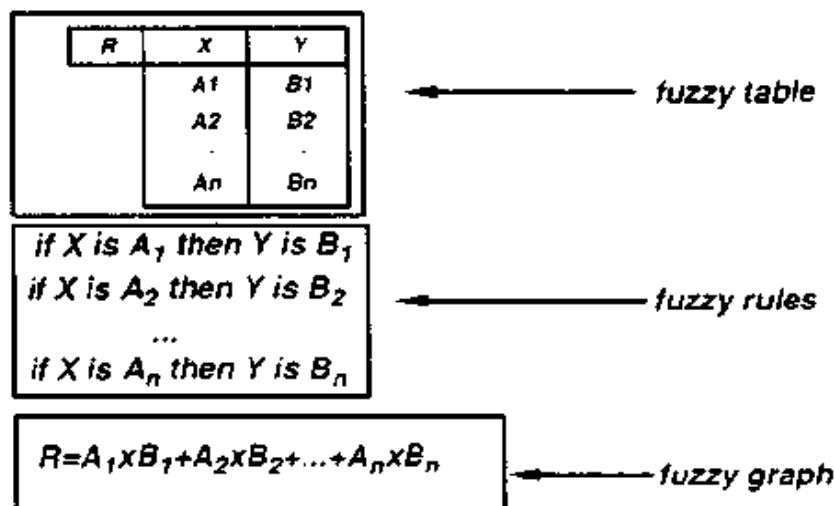

Fig. 22. Representation of a fuzzy function (or relation) as a fuzzy table, fuzzy rule set and a fuzzy graph.

$$\begin{aligned} f^* &= A_1 \times B_1 + \dots + A_n \times B_n \\ &= \sum_1 A_i \times B_i, \quad i=1, \dots, n \end{aligned}$$

where  $+$  represents disjunction. A point of key importance is that the fuzzy graph  $f^*$  may be viewed as a  $f$ -granular approximation of  $f$ . For example, in the case of the function



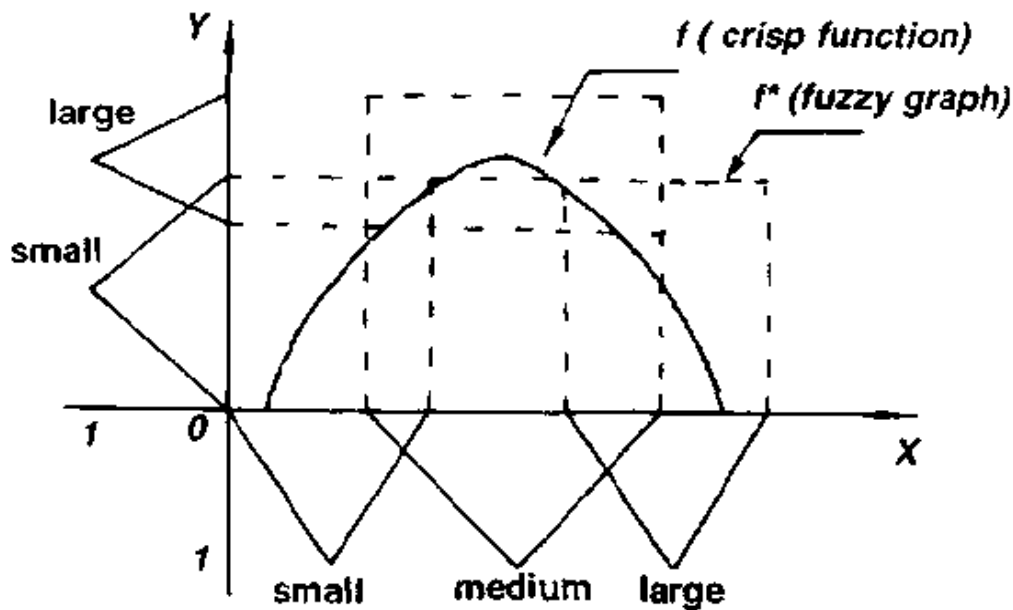

Fig. 23. A fuzzy graph approximation to a function.

shown in Fig. 23, the fuzzy-graph approximation may be expressed as

$$f' = \text{small} \times \text{small} + \text{medium} \times \text{large} + \text{large} \times \text{small}.$$

In this and other cases, the coarseness of granulation is determined by the desired degree of approximation.

There are four basic rationales for f, g-granulation of functions and relations.

1. *Crisp, fine-grained information is not available.*  
Examples: economic systems, everyday decision-making.
2. *Precise information is costly.*  
Examples: diagnostic systems, quality control, decision analysis.
3. *Fine-grained information is not necessary.*  
Examples: Parking a car, cooking, balancing.
4. *Coarse-grained information reduces cost.*

Examples: Throw-away cameras, consumer products.  
Underlying these rationales is the basic guiding principle of fuzzy logic:

*Exploit the tolerance for imprecision, uncertainty and partial truth to achieve tractability, robustness, low solution cost and better rapport with reality.*

In the context of this principle, the importance of f-granulation derives principally from the fact that it paves the way for a far more extensive use of the machinery of fuzzy information granulation than is the norm at this juncture in both theory and applications.

A case in point relates to the use of crisply defined probability distributions in decision analysis. More specifically, although probability theory is precise and rigorous, its rapport with the real world is far from perfect, largely because most real-world probabilities are poorly defined or hard to estimate. For example, I may need to know the probability that my car may be stolen to decide on whether or not to insure it and for what amount. But probability theory provides no ways for estimating the probability in question. What it does offer is a way of elicitation of subjective probabilities but begs the question of how an estimate of subjective probability can be formed.

In this and similar cases what may work is f-granulation of probability distributions. More specifically, assume for simplicity that  $X$  is a discrete random variable taking values  $a_1, \dots, a_n$  with respective probabilities  $p_1, \dots, p_n$ . Such distributions will be referred to as *singular* and the probabilistic constraint on  $X$  may be expressed as  $X \text{ is } p (p_1 \setminus a_1 + \dots + p_n \setminus a_n)$ . A probability

distribution is *semi-granular* (singular\granular) if it is of the form  $X \text{ is } p (p_1 \setminus A_1 + \dots + p_n \setminus A_n)$  where  $A_1, \dots, A_n$  are fuzzy granules. Semi-granular probability distributions of this type define a random set. Furthermore, they play an important role in the Dempster-Shafer theory of evidence.

A probability distribution is *semi-granular* (granular\singular) if it is of the form  $X \text{ is } p (P_1 \setminus a_1 + \dots + P_n \setminus a_n)$  where  $P_1, \dots, P_n$  are granular probabilities.

A probability distribution is *granular* if it is of the form

$$X \text{ is } p (P_1 \setminus A_1 + \dots + P_n \setminus A_n) \quad (3)$$

signifying that  $X$  is a granular random variable, taking granular (linguistic) values  $A_1, \dots, A_n$  with granular (linguistic) probabilities  $P_1, \dots, P_n$ . The granules  $A_1, \dots, A_n$  may be possibilistic or veristic. Granular probability distributions of the form (3) were discussed in [31] in the context of the Dempster-Shafer theory of evidence.

A simple example of a granular probability distribution is shown in Fig. 24. In this example,

$$X \text{ is } p (P_1 \setminus A_1 + P_2 \setminus A_2 + P_3 \setminus A_3), \quad (4)$$

or, more specifically,

$$X \text{ is } p (\text{small} \setminus \text{small} + \text{large} \setminus \text{medium} + \text{small} \setminus \text{large}).$$

An important concept in the context of granular probability distributions is that of *p-dominance*. More specifically, if in (4) there is a value,  $A_j$ , whose probability dominates that of all other values of  $X$  then  $A_j$  is said to be *p-dominant* or, equivalently, the *usual value* of  $X$  (Fig. 24). The importance of *p-dominance* derives from the fact that in everyday reasoning and discourse it is common practice to

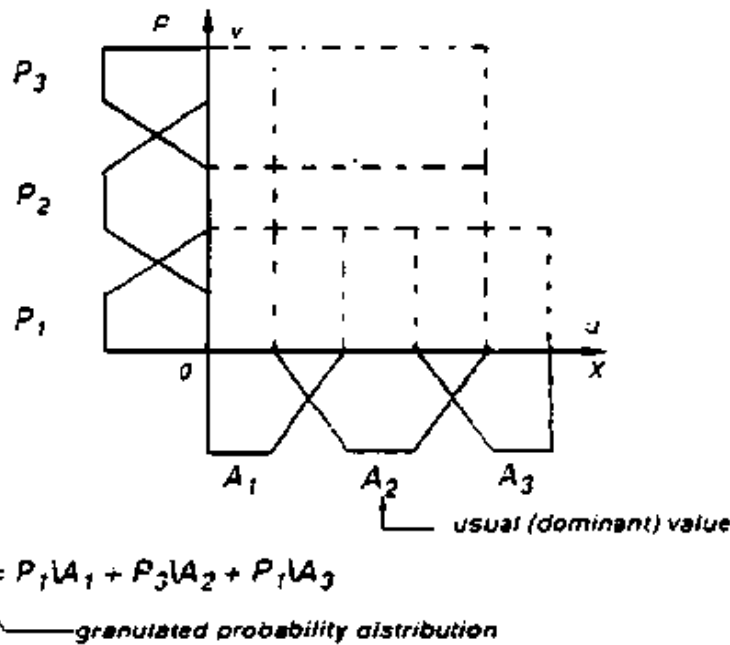

Fig. 24. A granulated (granular) probability distribution.

approximate to

$$X \text{ is } p (P_1 \setminus A_1 + \dots + P_n \setminus A_n)$$

by

$$X \text{ is } A_j$$

if  $A_j$  is a  $p$ -dominant value of  $X$ . For example, in the case of (4), one may assert that

$$X \text{ is } \textit{medium} \tag{5}$$

with the understanding that (5) is not a categorical statement but an approximation to

$$\textit{usually} (X \text{ is } \textit{medium})$$

where the fuzzy quantifier *usually* may be interpreted as a fuzzy number which represents the probability of the fuzzy event  $\{X \text{ is } \textit{medium}\}$ .

## 6. Fuzzy granulation in a general setting

As was alluded to already, the methodology of  $f$ -granulation of variables, functions and relations has played and is continuing to play a major role in the applications of fuzzy logic. Within the theory of fuzzy information granulation, the methodology of  $f$ -granulation is developed in a much more general setting, enhancing the applicability of  $f$ -granulation and widening its impact. This is especially true of  $f$ -granulation of functions, since the concept of a function is ubiquitous in all fields of science and engineering.

As a simple illustration of this point consider the standard problem of maximization of an objective function in decision analysis. Let us assume, as is frequently the case in real-world problems, that the objective function,  $f$ , is not well-defined and that what we know about  $f$  can be expressed as a fuzzy rule set

$$\begin{aligned} f^* : & \text{if } X \text{ is } A_1 \text{ then } Y \text{ is } B_1 \\ & \text{if } X \text{ is } A_2 \text{ then } Y \text{ is } B_2 \\ & \dots \\ & \text{if } X \text{ is } A_n \text{ then } Y \text{ is } B_n \end{aligned}$$

or, equivalently, as a fuzzy graph

$$f = \sum_i A_i \times B_i.$$

The question is: What is the point or, more generally, the maximizing set at which  $f$  is maximized, and what is the maximum value of  $f$ ? (Fig. 25)

The problem can be solved by employing the technique of  $\alpha$ -cuts. With reference to Fig. 26, if  $A_i$  and  $B_i$  are  $\alpha$ -cuts of  $A_i$  and  $B_i$ , respectively, then the corresponding  $\alpha$ -cut of  $f$  is given by  $f_\alpha$

function maximization

$f$ : if  $X$  is small then  $Y$  is small  
 if  $X$  is medium then  $Y$  is large  
 if  $X$  is large then  $Y$  is small

problem: maximize  $f$

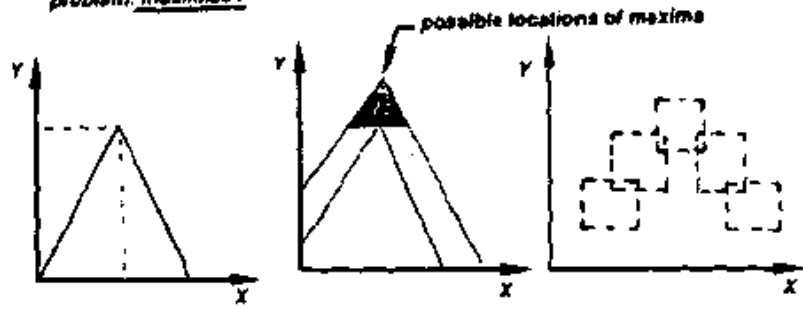

Fig. 25. Maximization of a function,  $f$ , defined by a fuzzy rule set or a fuzzy graph.

$= \sum_i A_i \times B_i$ . From this expression, the maximizing fuzzy set, the maximum fuzzy set and maximum value fuzzy set can readily be derived, as shown in Fig. 27.

$f = \text{small} \times \text{small} + \text{medium} \times \text{large} + \text{large} \times \text{small}$

$$f = \sum_i A_i \times B_i$$

$$f_\alpha = \{(u, v) \mid \mu_f(u, v) \geq \alpha\}$$

$$f_\alpha = \sum_i A_{i_\alpha} \times B_{i_\alpha}$$

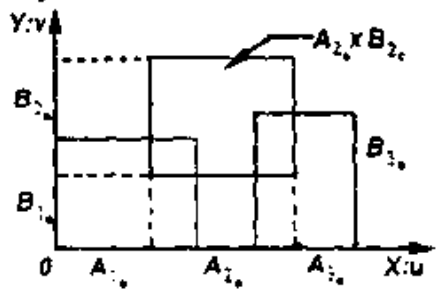

Fig. 26.  $\alpha$ -cuts of the fuzzy graph of  $f$ .

In a similar vein, one can ask "What is the integral of  $f$ ; What are the roots of  $f$ ; etc.?" Problems of this type fall within the province of computing with words [37].

Another illustration is provided by the extension principle

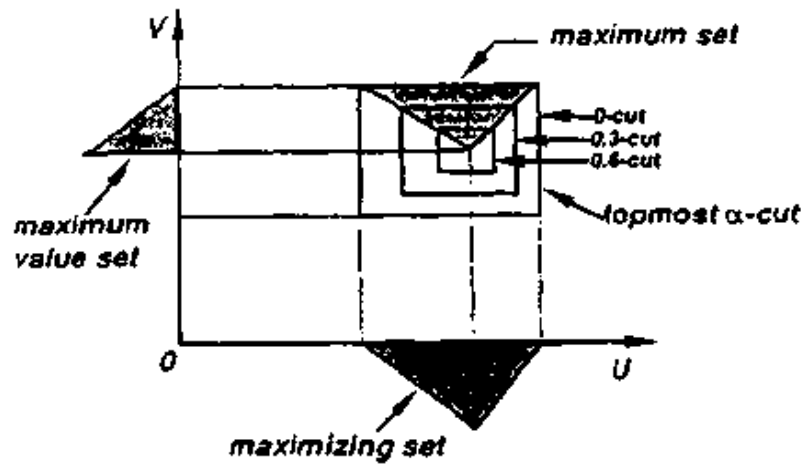

Fig. 27. The maximizing set, the maximum value set and the maximum set of a fuzzy graph.

[24, 36, 37], which is a basic rule of inference in fuzzy logic and is expressible as the inference schema

$$\frac{X \text{ is } A}{f(x) \text{ is } f(A)}$$

where  $f: U \rightarrow V$  and

$$\mu_{f(A)}(v) = \sup_{u|v=f(u)} \mu_A(u).$$

Let us apply  $f$ -granulation to  $f$ , yielding the rule set

$$f: \text{if } X \text{ is } A_i \text{ then } Y \text{ is } B_i, \quad i=1, \dots, n.$$

In this case, the problem reduces to the familiar interpolation schema in the calculus of fuzzy rules:

$$\begin{array}{c} X \text{ is } A \\ \text{if } X \text{ is } A_i \text{ then } Y \text{ is } B_i, \quad i=1, \dots, n \\ Y \text{ is } \sum_i m_i \wedge B_i \end{array}$$

where the matching coefficient  $m_i$  is given by

$$m_i = \sup (A \cap A_i).$$

The examples discussed above suggest an important

direction in the development of TFIG. Specifically, the examples in question may be viewed as f. g-generalizations of standard problems and techniques. Thus, in the first example the standard problem is that of maximization, while in the second problem f. g-generalizations is applied to the extension principle.

### 6.1. *The airport shuttle problem*

Another example in this spirit is what might be called the Airport Shuttle problem, a problem which may be viewed as an f. g-generalizations of the standard Traveling Salesman problem. In this case, an airport shuttle picks up passengers at an airport and takes them to specified addresses. The objective of the driver is to return to the airport as soon as possible (Fig. 28).

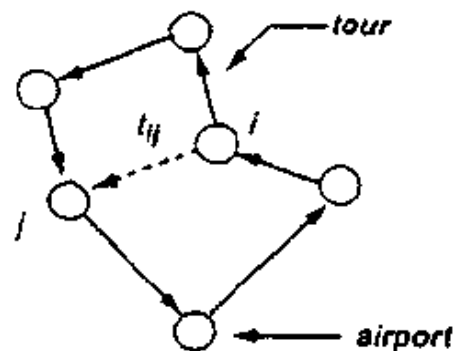

*transit time  $t_{ij}$  : fuzzy probability estimate  
from experience and fuzzy interpolation*

Fig. 28. The airport shuttle problem.

The difference between this problem and the Traveling Salesman problem is that in the case of the Traveling Salesman problem the cost of going from node  $i$  to node  $j$  is known for all  $i, j$ , whereas in the Airport Shuttle problem the transit time from



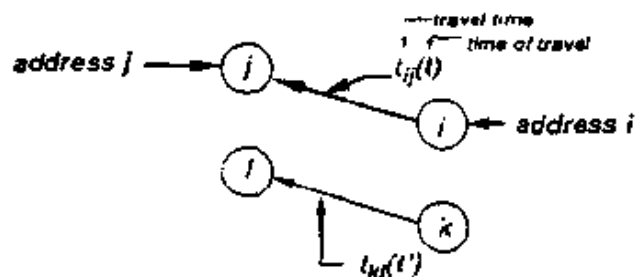

*in memory:*

*fuzzy values of  $t_{kl}(t)$  for  $k, l$  and  $t$  which approximate to  $i, j, t$ .*

*double interpolation*

Fig. 29. Interpolation in time and space in the airport shuttle problem.

address  $i$  to address  $j$  has to be estimated by the driver. The driver does so by interpolating the data stored in the driver's memory, performing interpolation in both time and space (Fig. 29). In an intuitive way, the driver approximates to the transit time by a coarse granular probability distribution. In arriving at a decision on the order in which the passengers should be taken of their destinations, the driver uses an intuitive form of  $p$ -dominance. This, of course, is merely a coarse perception of what goes on in the driver's mind.

In the problem under consideration, fuzzy information granulation in an intuitive form underlies the human solution. What this suggests is that no machine could solve the problem without using, as human do, the machinery of fuzzy information granulation. How this could be done in detail is a challenge that has not as yet been met.

## 6.2. *The commute time problem*

Another problem of this type, a problem which makes the same point, is what might be called the Commute Time problem.

The problem may be formulated in two versions: (a) unannotated; and (b) annotated.

In the unannotated version we are given a time series such as

$$T_a: \{15, 18, 21, 14, 20, \theta, \theta, 13, 0, 3, 18, 17, \theta, 19, \dots\}$$

with no knowledge of what the numbers represent or how they were obtained. The questions posed are the following

1. Does  $T_a$  represent the result of a random experiment?
2. If it does, what is the sample space? What are the random variables? Is  $T_a$  stationary?
3. Given the elements of  $T_a$  up to and including  $t=i$ , what would be an estimate of  $T_a$  at time  $i+1$ ?

The unannotated version has neither a human nor a machine solution. In particular, standard probability theory provides no answers to the posed questions. Nevertheless, there are programs which, given an unannotated time series, will come up with a prediction. It can be argued that such predictions have no justification.

In the annotated version, the time-series reads:

$$T_b: \{ (Mon, 15), (Tue, 18), (Wed, 21), (Thu, 14), \\ (Fri, 20), (Sat, \theta), (Sun, \theta), (Mon, 13), \dots, \}$$

and has the following meaning.

$T_b$  represents a record of the time it took me to commute from my home to the campus, starting with Monday, 1 January, 1996;  $\theta$  means that I did not go to the campus that day; it took

longer on Wednesday, 3 January, because of rain; usually it takes longer on Fridays. etc.

Suppose that in the morning of Wednesday, 20 March, I had to estimate the commute time that day, knowing that it would be slightly shorter than 18 min on Wednesday, 13 March, because of the Spring recess which started on 18 March. Everything considered, my estimate might be; around 18 min.

The point of this example is that the problem has a human solution arrived at through human reasoning based on  $f$ -granulated information. Neither standard probability theory nor any methodology which does not employ the machinery of fuzzy information granulation can come up with a machine solution. The challenge, then, is to develop a theory of fuzzy information granulation which can model the ways in which human granulate information and reason with it. In a preliminary way, this is what we have attempted to do in this paper.

## **7. Concluding remark**

The machinery of fuzzy information granulation, especially in the form of linguistic variables, fuzzy if-then rules and fuzzy graphs, has long played a major role in the applications of fuzzy logic. What has not been fully recognized, however, is the centrality of fuzzy information granulation in human reasoning and, ipso facto, its centrality in fuzzy logic. A related point is that no methodology other than fuzzy logic provides a conceptual framework and associated techniques for dealing with problems in which fuzzy information granulation plays, or could play, a major role. In the context of such problems, the way in which

humans employ fuzzy information granulation to make rational decisions in an environment of partial knowledge, partial certainty and partial truth should be viewed as a role model for machine intelligence.

The theory of fuzzy information granulation outlined in this paper takes the existing machinery of fuzzy information granulation in fuzzy logic to a higher level of generality, consolidates its foundations and suggests new directions. In coming years, TFIG is likely to play an important role in the evolution of fuzzy logic and, in conjunction with computing with words, may eventually have a far-reaching impact on its applications.

## References

- [1] D. Driankov, H. Hellendoorn, M. Reinfrank, *An Introduction to Fuzzy Control*, Springer, Berlin, 1993.
- [2] D. Dubois, H. Fargier, H. Prade. Possibility theory in constraint satisfaction problems: Handling priority, preference and uncertainty, *Applied Intelligence* 6 (1996) 287~309.
- [3] D. Dubois, J. Lang, H. Prade, Possibilistic Logic, in: *Handbook of Logic in Artificial Intelligence and Logic Programming*, vol. 3, D. M. Gabbay, C. J. Hogger, J. A. Robinson, D. Nute (Eds.), Oxford Univ. Press, Oxford, 1994, 439~513.
- [4] D. Dubois, H. Prade, Fuzzy sets in approximate reasoning, Part I ; Interference with possibility distributions ; Part II ; Logical approaches (with J. Lang), *Fuzzy Sets and Systems* Vol. 40, Part I ; pp. 143~202 ; Part I ; pp. 203~244 (1991).

- [5] D. Dubois, H. Prade, Putting rough sets and fuzzy sets together, in: Intelligent Decision Support-Handbook of Applications and Advances of the Rough Sets Theory, R. Slowinski, Ed. , Kluwer, Dordrecht, 1992, 203~232.
- [6] D. Dubois, H. Prade, R. Yager (Eds. ), Readings in Fuzzy Sets for Intelligent Systems, Morgan Kaufmann, San Mateo, 1993.
- [7] D. Dubois, H. Prade, R. Yager (Eds. ), Fuzzy Information Engineering, Wiley, New York, 1997.
- [8] J. A. Goguen, The logic of inexact concepts, Synthese 19 (1969) 325 ~373.
- [9] M. Jamshidi, N. Vadiie, T. Ross (Eds. ), Fuzzy Logic and Control, Prentice-Hall, Englewood Cliffs, NJ, 1993.
- [10] G. Klir, B. Yuan, Fuzzy Sets and Fuzzy Logic, Prentice-Hall, Englewood Cliffs, 1995.
- [11] B. Kosko, Neural Networks and Fuzzy Systems: A Dynamical Systems Approach to Machine Intelligence, Prentice-Hall, Englewood Cliffs, NJ, 1991.
- [12] R. Kruse, J. Gebhardt, F. Klawonn, Foundations of Fuzzy Systems, Wiley, New York, 1994.
- [13] C. C. Lee, Fuzzy logic in control systems: Fuzzy logic controller, parts I and II, IEEE Trans. Systems, Man Cybernet. 20 (1990), 404~418.
- [14] E. H. Mamdani, B. R. Gaines (Eds. ), Fuzzy Reasoning and its Applications. Academic Press, London, 1981.
- [15] M. Mares, Computation Over Fuzzy Quantities, CRC Press. Boca Raton, 1994.
- [16] V. Novak, Fuzzy logic, fuzzy sets, and natural languages, Internat. J. General Systems 20 (1) (1991) 83~97.
- [17] V. Novak, M. Ramik, M. Cerny, J. Nekola (Eds. ), Fuzzy Approach to Reasoning and Decision-Making, Kluwer, Boston, 1992.
- [18] Z. Pawlak, Rough sets, Internat. J. Comput. Inform. Sci. 11

(1982) 341~356.

- [19] W. Pedrycz, *Fuzzy Control and Fuzzy Systems*, Wiley, New York, 1989.
- [20] T. Terano, K. Asai, M. Sugeno, *Fuzzy Systems Theory and its Applications*, Academic Press, New York, 1992.
- [21] C. von Altrock, *Fuzzy Logic & Neurofuzzy Applications Explained*, PTR Prentice-Hall, Englewood, NJ, 1995.
- [22] L. X. Wang, *Adaptive Fuzzy Systems and Control: Design Stability Analysis*, PTR Prentice-Hall, Englewood Cliffs, NJ, 1994.
- [23] J. Yen, R. Langari, L. A. Zadeh (Eds.), *Industrial Applications of Fuzzy Logic and Intelligent Systems*, IEEE Press, New York, 1995.
- [24] L. A. Zadeh, Fuzzy sets, *Inform. and Control* 8 (1965) 338~353.
- [25] L. A. Zadeh, Shadows of fuzzy sets, *Prob. Trans. Inform.* 2 (1966) 37~44.
- [26] L. A. Zadeh, Toward a theory of fuzzy systems, in: R. E. Kalman, N. DeClaris (Eds.), *Aspects of Network and System Theory*, Rinehart & Winston, New York, 1971, 469~490.
- [27] L. A. Zadeh, Outline of a new approach to the analysis of complex system and decision processes, *IEEE Trans. Systems. Man, Cybernet.* 3 (1973) 28~44.
- [28] L. A. Zadeh, On the Analysis of Large Scale Systems, in: H. Gottinger (Ed.), *Systems Approaches and Environment Problems*, Vandenhoeck & Ruprecht, Gottingen; 1974, 23~37.
- [29] L. A. Zadeh, The concept of a linguistic variable and its applications to approximate reasoning Part I; *Inform. Sci.* 8 (1975) 199~249; Part II; *Inform. Sci.* 8 (1975) 301~357; Part III; *Inform. Sci.* 9 (1975) 43~80.
- [30] L. A. Zadeh, A fuzzy-algorithmic approach to the definition of complex or imprecise concepts, *Internat. J. Man-Machine Stud.* 8 (1976) 249~291.
- [31] L. A. Zadeh, Fuzzy Sets and Information Granularity, in: M. Gupta, R. Ragade, R. Yager (Eds.), *Advances in Fuzzy Set Theory and*

Applications, North-Holland, Amsterdam, 1979, 3~18.

- [32] L. A. Zadeh, Outline of a computational approach to meaning and knowledge representation based on a concept of a generalized assignment statement, in: M. Thoma A. Wyner (Eds.), Proc. of the Internat. Seminar on Artificial Intelligence and Man-Machine Systems, Springer Heidelberg, 1986, 198~211.
- [33] L. A. Zadeh, Outline of a theory of usuality based on fuzzy logic, Reidel, Dordrecht, Fuzzy Sets Theory and Applications, in: A. Jones, A. Kaufmann, H. J. Zimmerman (Eds.), 1986, 79~97.
- [34] L. A. Zadeh, Fuzzy logic, neural networks and soft computing, Commun. ACM 37 (3) (1994) 77~84.
- [35] L. A. Zadeh, Why the success of fuzzy logic is not paradoxical, IEEE Expert 9 (4) (1994) 43~45.
- [36] L. A. Zadeh, Fuzzy logic and the calculi of fuzzy rules and fuzzy graphs, Multiple Valued Logic 1 (1996) 1~38.
- [37] L. A. Zadeh, Fuzzy logic=computing with words, IEEE Trans. on Fuzzy Systems 4 (1996) 103~111.
- [38] H. J. Zimmerman, Fuzzy Set Theory and Its Applications, 3rd ed., Kluwer-Nijhoff, Amsterdam, 1996.

## What Is Soft Computing?

Since the publication of my first paper on soft data analysis in 1981, the concept of soft computing has undergone many changes. In its latest incarnation, soft computing may be defined informally as follows.

Soft computing (SC) is an association of computing methodologies centering on fuzzy logic (FL), neurocomputing (NC), genetic computing (GC), and probabilistic computing (PC). The methodologies comprising soft computing are for the most part complementary and synergistic rather than competitive.

The guiding principle of soft computing is: exploit the tolerance for imprecision, uncertainty, partial truth, and approximation to achieve tractability, robustness, low solution cost and better rapport with reality. One of the principal aims of soft computing is to provide a foundation for the conception, design and application of intelligent systems employing its member methodologies symbiotically rather than in isolation.

Within soft computing, the main concerns of fuzzy logic, neurocomputing, genetic computing and probabilistic computing center on;

FL: approximate reasoning, information granulation, computing with words,

NC: learning, adaptation, classification, system modelling



and identification,

GC: synthesis, tuning and optimization through systematized random search and evolution,

PC: management of uncertainty, belief networks, prediction, chaotic systems.

As an association of computing methodologies, soft computing is certain to grow in visibility and importance in the years ahead. What is the rationale behind this expectation? In my view, a key reason is related to the growing realization that the conceptual structure of conventional, hard computing is much too precise in relation to the pervasive imprecision of the real world.

In this context, there are two distinct issues that have to be considered. First, there are many real world problems which do not lend themselves to solution by the techniques of hard computing because the needed information is not available and or the systems under consideration are not sufficiently well defined. Such problems are the norm in economic planning, living systems, large-scale societal systems and human decision-making. Another source of such problems is AI, especially in the realms of commonsense reasoning, computer vision and natural language understanding. Indeed, it may be argued that it is the commitment of mainstream AI to hard computing and its coolness toward soft computing that impeded AI's ability to achieve the ambitious goals that were set at its inception.

The other and perhaps more important reason is that employment of soft computing methodologies serves to exploit the tolerance for imprecision, uncertainty, partial truth and approximation. In so doing, soft computing mimics the

remarkable human ability to make rational decisions in an environment of uncertainty and imprecision. A case in point is the problem of parking a car. The tolerance for imprecision in this problem makes it possible for humans to park a car without any measurement and any knowledge of system dynamics. Without exploiting the tolerance for imprecision, the parking problem becomes intractable for humans and very hard for machines.

Exploitation of the tolerance for imprecision, uncertainty, partial truth and approximation plays a pivotal role in data compression, information retrieval and communication. In this realm, fuzzy logic plays a particularly important role by providing a methodology for dealing with information granulation and computing with words in ways that mimic human reasoning and concept formation. In essence, the role model for fuzzy logic is the human mind.

An aspect of soft computing that is of central importance is the symbiotic relationship between its constituent methodologies. What this implies is that in the solution of many problems especially in the conception and design of intelligent systems it is advantageous to employ a combination of two or more of the constituent methodologies of soft computing, leading to what is referred to as HYBRID INTELLIGENT SYSTEMS. Currently, the most visible systems of this type are neuro-fuzzy systems. However, we are also beginning to see a growing number of fuzzy-genetic, neuro-genetic and neuro-fuzzy-genetic systems. Such systems are likely to become ubiquitous in the not distant future. What is certain is that in the years ahead the advent of hybrid intelligent systems will have a profound impact

on the ways in which intelligent systems are conceived, designed, employed and interacted with.

Viewed in this perspective, the publication of *Soft Computing* is an important event in the crystallization of soft computing as a prominent component of modern science and information technology. The publication of *Soft Computing* realizes the vision of the editors, the authors and the publisher a vision which could not become a reality without the invaluable initiative and support of the SGS-THOMSON Corporation.